



TGBR40V60C

Preliminary

DIODE

DUAL TRENCH MOS SCHOTTKY BARRIER RECTIFIER

DESCRIPTION

The UTC **TGBR40V60C** is a dual trench mos schottky barrier rectifier, it uses UTC's advanced technology to provide customers with low forward voltage drop and high switching speed, etc.

FEATURES

- * Very low forward voltage drop
- * High switching speed

SYMBOL

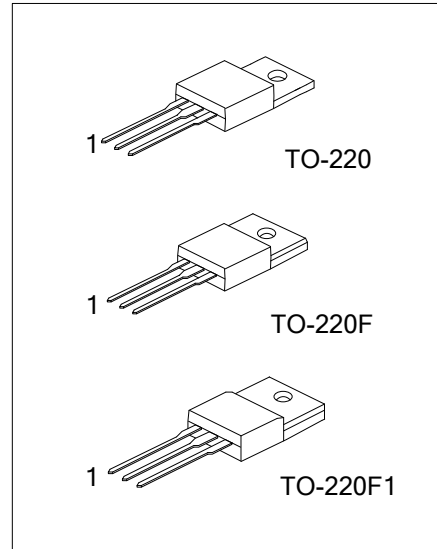
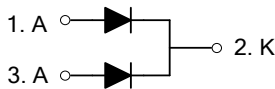

ORDERING INFORMATION

Ordering Number		Package	Pin Assignment			Packing
Lead Free	Halogen Free		1	2	3	
TGBR40V60CL-TA3-T	TGBR40V60CG-TA3-T	TO-220	A	K	A	Tube
TGBR40V60CL-TF1-T	TGBR40V60CG-TF1-T	TO-220F1	A	K	A	Tube
TGBR40V60CL-TF3-T	TGBR40V60CG-TF3-T	TO-220F	A	K	A	Tube

Note: Pin Assignment: A: Anode K: Cathode

TGBR40V60CG-TA3-T	(1)Packing Type	(1) T: Tube
	(2)Package Type	(2) TA3: TO-220, TF1: TO-220F1, TF3: TO-220F
	(3)Green Package	(3) G: Halogen Free and Lead Free, L: Lead Free

MARKING

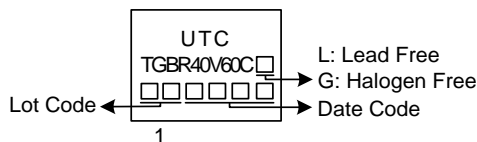

■ ABSOLUTE MAXIMUM RATINGS (T_A=25°C, unless otherwise specified)

Single phase, half wave, 60Hz, resistive or inductive load.

For capacitance load, derate current by 20%.

PARAMETER		SYMBOL	RATINGS	UNIT
DC Blocking Voltage		V _{RM}	60	V
Working Peak Reverse Voltage		V _{RWM}	60	V
Peak Repetitive Reverse Voltage		V _{RRM}	60	V
Average Rectified Output Current (T _C =140°C)	Per Leg	I _O	20	A
	Total		40	A
Non-Repetitive Peak Forward Surge Current 8.3ms Single Half Sine-Wave Superimposed on Rated Load		I _{FSM}	250	A
Operating Junction Temperature		T _J	-65 ~ +150	°C
Storage Temperature		T _{STG}	-65 ~ +150	°C

Note: Absolute maximum ratings are those values beyond which the device could be permanently damaged.
Absolute maximum ratings are stress ratings only and functional device operation is not implied.

■ THERMAL CHARACTERISTICS (PER LEG)

PARAMETER		SYMBOL	RATINGS	UNIT
Junction to Ambient		θ _{JA}	62.5	°C/W
Junction to Case	TO-220	θ _{JC}	2	°C/W
	TO-220F		3.31	
	TO-220F1			

■ ELECTRICAL CHARACTERISTICS (Per Leg) (T_A=25°C, unless otherwise specified.)

PARAMETER	SYMBOL	TEST CONDITIONS	MIN	TYP	MAX	UNIT
Reverse Breakdown Voltage (Note 1)	V _{(BR)R}	I _R =0.50mA	60			V
Forward Voltage Drop	V _{FM}	I _F =20A, T _J =25°C			0.65	V
		I _F =20A, T _J =125°C			0.60	V
Leakage Current (Note 1)	I _{RM}	V _R =60V, T _J =25°C			500	μA
		V _R =60V, T _J =125°C			100	mA

Notes: 1. Short duration pulse test used to minimize self-heating effect.

2. Thermal resistance junction to case mounted on heatsink.

UTC assumes no responsibility for equipment failures that result from using products at values that exceed, even momentarily, rated values (such as maximum ratings, operating condition ranges, or other parameters) listed in products specifications of any and all UTC products described or contained herein. UTC products are not designed for use in life support appliances, devices or systems where malfunction of these products can be reasonably expected to result in personal injury. Reproduction in whole or in part is prohibited without the prior written consent of the copyright owner. UTC reserves the right to make changes to information published in this document, including without limitation specifications and product descriptions, at any time and without notice. This document supersedes and replaces all information supplied prior to the publication hereof.