



## U74LVC3G07

CMOS IC

### TRIPLE BUFFER/DRIVER WITH OPEN-DRAIN OUTPUTS

#### DESCRIPTION

The **U74LVC3G07** is triple bus buffer/driver with open-drain outputs. The output can be connected to other open-drain outputs to implement active-low wired-OR or active-high wired-AND functions.

This device has power-down protective circuit, preventing device destruction when it is powered down.

This device is fully specified for partial-power-down applications using  $I_{off}$ . The  $I_{off}$  circuitry disables the outputs, preventing damaging current backflow through the device when it is powered down.

#### FEATURES

- \* Wide supply voltage range from 1.65V to 5.5V
- \* Inputs accept voltages up to 5.5V
- \*  $I_{OFF}$  supports partial-power-down mode
- \* Low static power consumption;  $I_{CC}=10\mu A$  (Max.)

#### ORDERING INFORMATION

Ordering Number		Package	Packing
Lead Free	Halogen Free		
U74LVC3G07L-S08-R	U74LVC3G07G-S08-R	SOP-8	Tape Reel
U74LVC3G07L-CK08-2030-R	U74LVC3G07G-CK08-2030-R	CDFN2030-8	Tape Reel

<p>U74LVC3G07G-S08-R</p> <ul style="list-style-type: none"> <li>(1) Packing Type</li> <li>(2) Package Type</li> <li>(3) Green Package</li> </ul>	<ul style="list-style-type: none"> <li>(1) R: Tape Reel</li> <li>(2) S08: SOP-8, CK08-2030: CDFN2030-8</li> <li>(3) G: Halogen Free and Lead Free, L: Lead Free</li> </ul>
--	--

#### MARKING

SOP-8	CDFN2030-8
<p>UTC □□□□ → Date Code  L: Lead Free  G: Halogen Free  □□□□ → Lot Code</p>	<p>LVC 3G07 • □□□□ → Date Code</p>

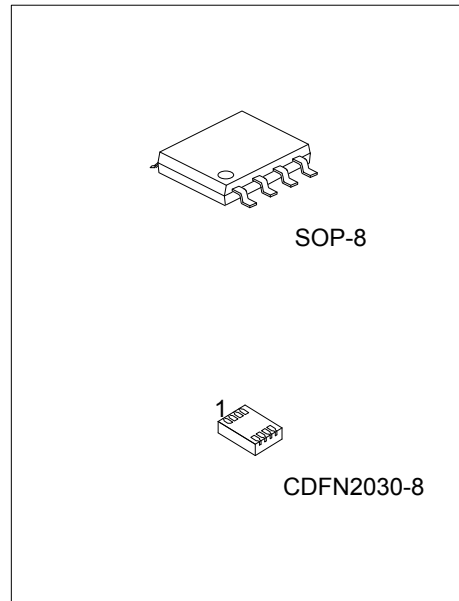

■ PIN CONFIGURATION

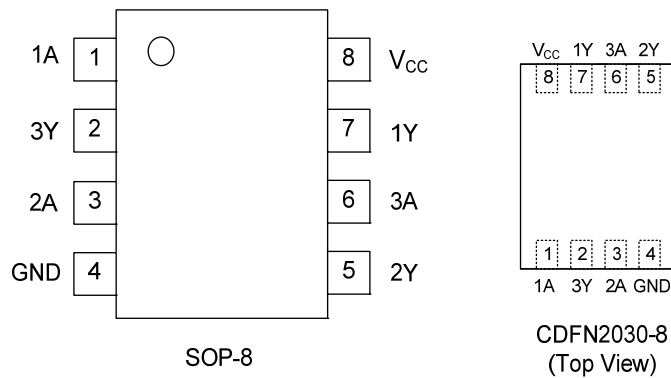

■ FUNCTION TABLE

INPUT(A)	OUTPUT(Y)
L	L
H	Z

Note: H: High voltage level; L: Low voltage level.

■ LOGIC DIAGRAM (positive logic)

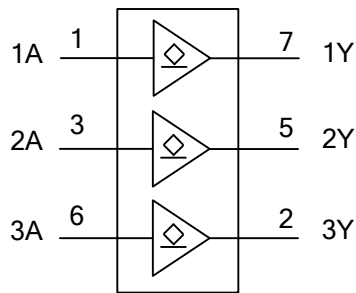

Logic symbol

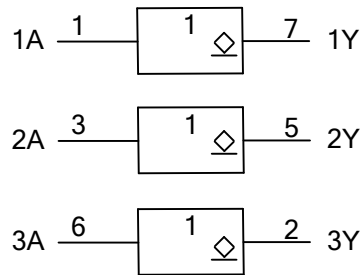

IEC logic symbol

### ■ ABSOLUTE MAXIMUM RATING

PARAMETER	SYMBOL	CONDITIONS	RATINGS	UNIT
Supply Voltage	$V_{CC}$		-0.5 ~ +6.5	V
Input Voltage	$V_{IN}$		-0.5 ~ +6.5	V
Output Voltage	$V_{OUT}$	Output in the high or low state	-0.5 ~ +6.5	V
		Output in the power-off state	-0.5 ~ +6.5	V
Continuous $V_{CC}$ or GND Current	$I_{CC}$		±100	mA
Continuous Output Current	$I_{OUT}$	$V_{OUT}=0V \sim V_{CC}$	±50	mA
Input Clamp Current	$I_{IK}$	$V_{IN}<0V$	-50	mA
Output Clamp Current	$I_{OK}$	$V_{OUT}>V_{CC}$ or $V_{OUT}<0V$	-50	mA
Storage Temperature Range	$T_{STG}$		-65 ~ +150	°C

Note: Absolute maximum ratings are those values beyond which the device could be permanently damaged. Absolute maximum ratings are stress ratings only and functional device operation is not implied.

### ■ RECOMMENDED OPERATING CONDITIONS

PARAMETER	SYMBOL	TEST CONDITIONS	MIN	TYP	MAX	UNIT
Supply Voltage	$V_{CC}$	Operating	1.65		5.5	V
		Data retention only	1.5			V
Input Voltage	$V_{IN}$		0		5.5	V
Output Voltage	$V_{OUT}$	High or low state	0		5.5	V
Operating Temperature (Note)	$T_A$		-40		+125	°C
Input Transition Rise or Fall Rate	$\Delta t/\Delta v$	$V_{CC}=1.8V\pm 0.15V, 2.5V\pm 0.2V$			20	ns/V
		$V_{CC}=3.3V\pm 0.3V$			10	ns/V
		$V_{CC}=5V\pm 0.5V$			5	ns/V

Note: This condition is only determined from design. It can't be 100% tested in mass production.

### ■ ELECTRICAL CHARACTERISTICS ( $T_A=25^\circ C$ , unless otherwise specified)

PARAMETER	SYMBOL	TEST CONDITIONS	MIN	TYP	MAX	UNIT
High-level Input Voltage	$V_{IH}$	$V_{CC}=1.8\pm 0.15V$	$0.65 \times V_{CC}$			V
		$V_{CC}=2.5\pm 0.2V$	1.7			V
		$V_{CC}=3.3\pm 0.3V$	2			V
		$V_{CC}=5\pm 0.5V$	$0.7 \times V_{CC}$			V
Low-level Input Voltage	$V_{IL}$	$V_{CC}=1.8\pm 0.15V$			$0.35 \times V_{CC}$	V
		$V_{CC}=2.5\pm 0.2V$			0.7	V
		$V_{CC}=3.3\pm 0.3V$			0.8	V
		$V_{CC}=5\pm 0.5V$			$0.3 \times V_{CC}$	V
Low-Level Output Voltage	$V_{OL}$	$V_{CC}=1.65 \sim 5.5V, I_{OL}=100\mu A$			0.1	V
		$V_{CC}=1.65V, I_{OL}=4mA$			0.45	V
		$V_{CC}=2.3V, I_{OL}=8mA$			0.3	V
		$V_{CC}=3.0V$ $I_{OL}=16mA$ $I_{OL}=24mA$			0.4	V
		$V_{CC}=4.5V, I_{OL}=32mA$			0.55	V
Input Leakage Current	$I_{I(LEAK)}$	$V_{CC}=0 \sim 5.5V, V_{IN}=5.5V$ or GND			±5	μA
Power OFF Leakage Current	$I_{off}$	$V_{CC}=0V, V_{IN}$ or $V_{OUT}=5.5V$			±10	μA
3-state Output OFF-state Current	$I_{OZ}$	$V_{IN}=V_{IH}$ or $V_{IL}, V_{OUT}=V_{CC}$ or GND, $V_{CC}=5.5V$			±10	μA
Quiescent Supply Current	$I_{CC}$	$V_{CC}=1.65 \sim 5.5V,$ $V_{IN}=V_{CC}$ or GND, $I_{OUT}=0A$			10	μA
Additional Quiescent Supply Current Per Input Pin	$\Delta I_{CC}$	$V_{CC}=3 \sim 5.5V,$ One input at $V_{CC}-0.6V,$ Other inputs at $V_{CC}$ or GND			500	μA
Input Capacitance	$C_I$	$V_{CC}=3.3V, V_{IN}=V_{CC}$ or GND		3.5		pF

■ SWITCHING CHARACTERISTICS ( $T_A = 25^\circ\text{C}$  , unless otherwise specified)

PARAMETER	SYMBOL	TEST CONDITIONS	MIN	TYP	MAX	UNIT
Propagation delay from input (A) to output(Y)	$t_{PZL} / t_{PLZ}$	$V_{CC}=1.8\pm 0.15\text{V}, C_L=30\text{pF}, R_L=1\text{k}\Omega$	1.5		7.8	ns
		$V_{CC}=2.5\pm 0.2\text{V}, C_L=30\text{pF}, R_L=500\Omega$	1.0		4.3	ns
		$V_{CC}=3.3\pm 0.3\text{V}, C_L=50\text{pF}, R_L=500\Omega$	1.1		3.7	ns
		$V_{CC}=5\pm 0.5\text{V}, C_L=50\text{pF}, R_L=500\Omega$	1.0		2.9	ns

■ OPERATING CHARACTERISTICS ( $f=10\text{MHz}, T_A = 25^\circ\text{C}$  , unless otherwise specified)

PARAMETER	SYMBOL	TEST CONDITIONS	MIN	TYP	MAX	UNIT
Power Dissipation Capacitance	$C_{PD}$	$V_{CC}=1.8\text{V}$		3		pF
		$V_{CC}=2.5\text{V}$		3		pF
		$V_{CC}=3.3\text{V}$		4		pF
		$V_{CC}=5\text{V}$		5		pF

## ■ TEST CIRCUIT AND WAVEFORMS

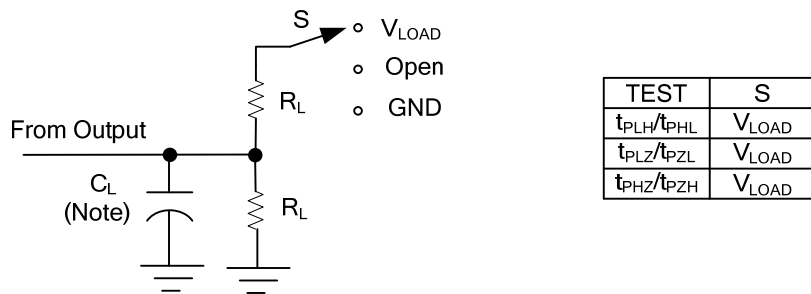

Note:  $C_L$  includes probe and jig capacitance.

$V_{CC}$	Inputs		$V_M$	$V_{LOAD}$	$C_L$	$R_L$	$V_{\Delta}$
	$V_{IN}$	$t_R, t_F$					
$1.8V \pm 0.15V$	$V_{CC}$	$\leq 2ns$	$V_{CC}/2$	$2 \times V_{CC}$	30pF	1K $\Omega$	0.15V
$2.5V \pm 0.2V$	$V_{CC}$	$\leq 2ns$	$V_{CC}/2$	$2 \times V_{CC}$	30pF	500 $\Omega$	0.15V
$3.3V \pm 0.3V$	3V	$\leq 2.5ns$	1.5V	6V	50pF	500 $\Omega$	0.3V
$5V \pm 0.5V$	$V_{CC}$	$\leq 2.5ns$	$V_{CC}/2$	$2 \times V_{CC}$	50pF	500 $\Omega$	0.3V

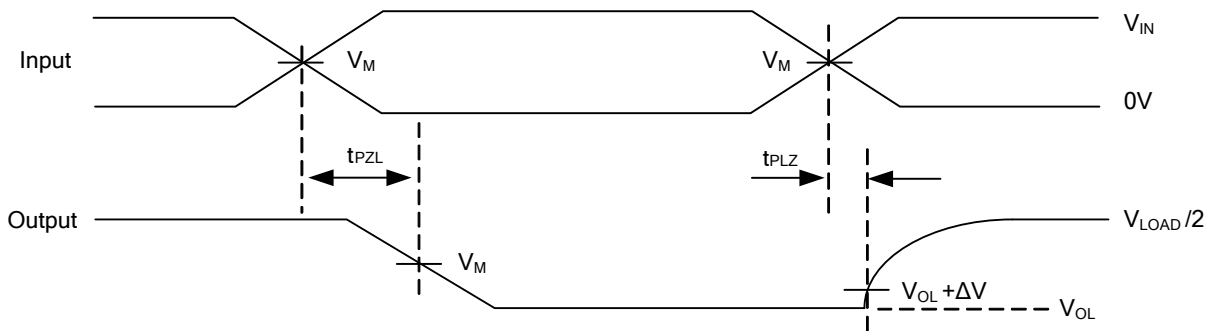

- Notes: 1.  $C_L$  includes probe and jig capacitance.  
 2. All input pulses are supplied by generators having the following characteristics: PRR  $\leq 10MHz$ ,  $Z_o = 50\Omega$ .

UTC assumes no responsibility for equipment failures that result from using products at values that exceed, even momentarily, rated values (such as maximum ratings, operating condition ranges, or other parameters) listed in products specifications of any and all UTC products described or contained herein. UTC products are not designed for use in life support appliances, devices or systems where malfunction of these products can be reasonably expected to result in personal injury. Reproduction in whole or in part is prohibited without the prior written consent of the copyright owner. UTC reserves the right to make changes to information published in this document, including without limitation specifications and product descriptions, at any time and without notice. This document supersedes and replaces all information supplied prior to the publication hereof.