



L3080

Preliminary

CMOS IC

30V/800mA INTEGRATED POWER LED DRIVER

DESCRIPTION

The UTC **L3080** is a continuous conduction mode inductive step-down converter, designed for driving single or multiple series connected LEDs. Using a few external components.

The UTC **L3080** has a build-in power switch, based on different input voltage, The UTC **L3080** can drive several 1W or 3W LEDs. The device has the function of thermal shutdown protection and LED short-circuit/open-circuit protection.

FEATURES

- * Up to 800mA output current
- * High efficiency (up to 97%)
- * Wide input voltage range: 5V~30V
- * Typical $\pm 5\%$ output current accuracy
- * Single DIM pin on/off and brightness control using DC voltage or PWM signal
- * LED open-circuit protection
- * LED short-circuit protection
- * Internal thermal shutdown protection.
- * Adjustable Constant LED Current

ORDERING INFORMATION

Ordering Number		Package	Packing
Lead Free	Halogen Free		
L3080L-AB5-R	L3080G-AB5-R	SOT-89-5	Tape Reel

<p>L3080G-AB5-R</p> <p>(1) Packing Type (2) Package Type (3) Green Package</p>	<p>(1) R: Tape Reel (2) AB5: SOT-89-5 (3) G: Halogen Free and Lead Free, L: Lead Free</p>
--	---

MARKING

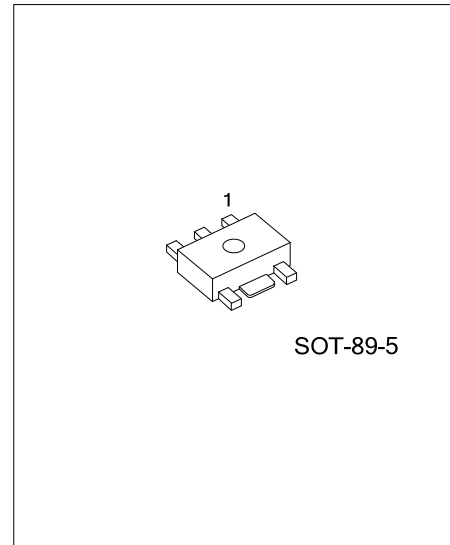
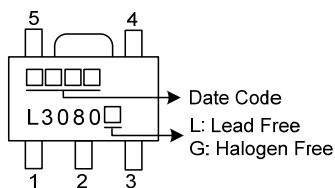

■ PIN CONFIGURATION

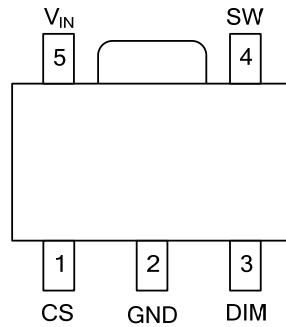

■ PIN DESCRIPTION

PIN NO.	PIN NAME	DESCRIPTION
1	CS	Current sense input
2	GND	Signal and power ground
3	DIM	Enable switch, analog and PWM dimming input.
4	SW	Switch output.
5	V _{IN}	Input supply pin.

■ BLOCK DIAGRAM

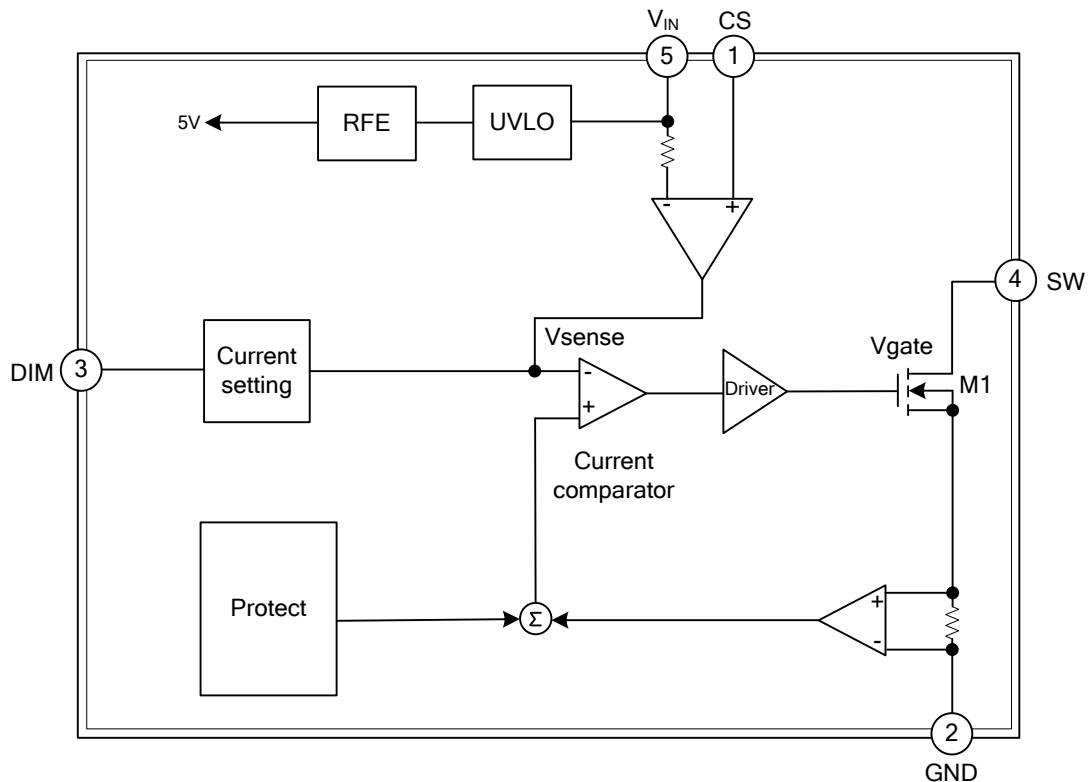

■ ABSOLUTE MAXIMUM RATING (T_A=25°C, unless specified otherwise)

PARAMETER	SYMBOL	RATINGS	UNIT
Supply Voltage	V _{IN}	40	V
Drain Voltage of the Internal Power Switch	SW	40	V
Current Sense Input (Respect to V _{IN})	CS	-6.0	V
Logic Level Dimming Input	DIM	-0.3 ~ 6	V
Switch Output Current	I _{SW}	1	A
Power Dissipation	P _D	0.8	W
Operation Junction Temperature Range	T _J	-40 ~ +150	°C
Storage Temperature	T _{STG}	-55 ~ +150	°C

Notes: 1. Absolute maximum ratings are those values beyond which the device could be permanently damaged.

Absolute maximum ratings are stress ratings only and functional device operation is not implied.

2. Human body model, 100pF capacitor discharged through a 1.5kΩ resistor.

■ THERMAL DATA

PARAMETER	SYMBOL	RATINGS	UNIT
Junction to Ambient	θ _{JA}	160	°C/W

■ ELECTRICAL CHARACTERISTICS (Note 1, 2)

(The following specifications apply for V_{IN}=12V, T_A=25°C, unless specified otherwise.)

PARAMETER	SYMBOL	TEST CONDITIONS	MIN	TYP	MAX	UNIT
Input Voltage	V _{IN}		5		30	V
Under Voltage Lock Out	V _{UVLO}	V _{IN} Falling		4.7		V
UVLO Hysteresis	V _{UVLO,HYS}	V _{IN} Rising		100		mV
CURRENT SENSE						
Mean Current Sense Threshold Voltage	V _{CS}	V _{IN} -V _{CS}		100		mV
Sense Threshold Hysteresis	V _{CS,HYS}			±15		%
OPERATING FREQUENCY						
Maximum Operation Frequency	F _{SW}				1	MHz
OPERATING CURRENT						
Quiescent Supply Current with Output Off	I _{OFF}	V _{DIM} <0.3V		60		μA
DIM INPUT						
Internal Supply Voltage	V _{DIM}	DIM Floating		5		V
DIM Input Voltage High	V _{DIM,H}			2.5		V
DIM Input Voltage Low	V _{DIM,L}			0.1		V
DIM Pull Up Resistor to Internal Supply Voltage	R _{DIM}			150		KΩ
DIM BRIGHTNESS DIMMER						
DC Brightness Control Range	V _{DIM,DC}		0.5		2.5	V
Duty Cycle Range of Low Frequency Dimming	D _{PWM,LF}			3000:1		
Duty Cycle Range of High Frequency Dimming	D _{PWM,HF}			10:1		
OUTPUT POWER SWITCH						
SW On Resistance	R _{SW}			0.6		Ω
Continuous SW Current	I _{SW,mean}				0.8	A
SW Leakage Current	I _{LEAK}			0.5	5	μA
THERMAL SHUTDOWN						
Thermal Shutdown Threshold	T _{SD}			150		°C
Thermal Shutdown hysteresis	T _{SD-hys}			20		°C

Notes: 1. Typical parameters are measured at 25°C and represent the parametric norm.

2. Datasheet min/max specification limits are guaranteed by design, test, or statistical analysis.

■ TYPICAL APPLICATION CIRCUIT

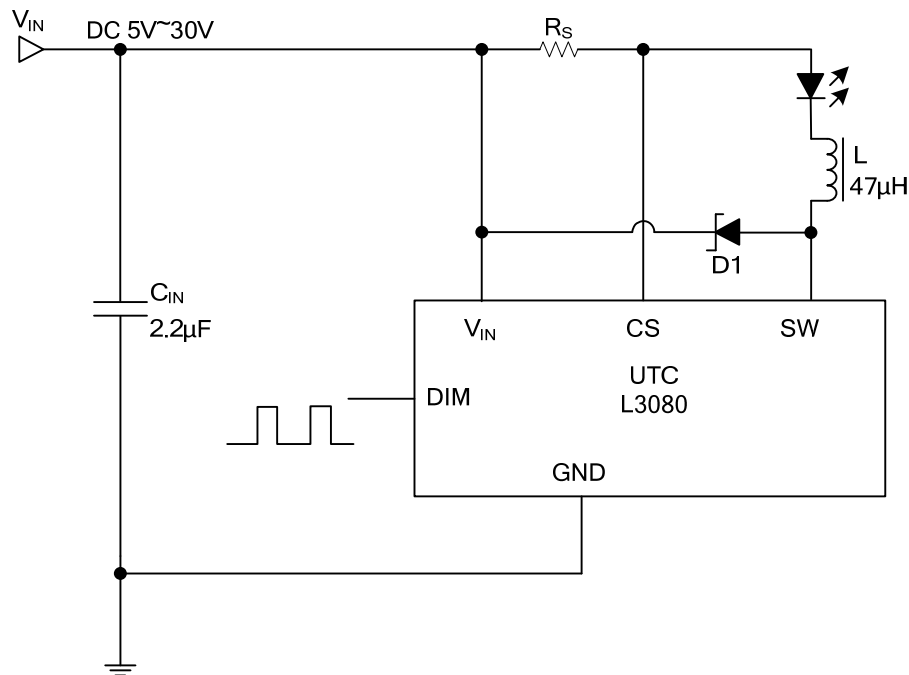

UTC assumes no responsibility for equipment failures that result from using products at values that exceed, even momentarily, rated values (such as maximum ratings, operating condition ranges, or other parameters) listed in products specifications of any and all UTC products described or contained herein. UTC products are not designed for use in life support appliances, devices or systems where malfunction of these products can be reasonably expected to result in personal injury. Reproduction in whole or in part is prohibited without the prior written consent of the copyright owner. UTC reserves the right to make changes to information published in this document, including without limitation specifications and product descriptions, at any time and without notice. This document supersedes and replaces all information supplied prior to the publication hereof.