



**3NM70**

Preliminary

**Power MOSFET**

**3.0A, 700V N-CHANNEL SUPER-JUNCTION MOSFET**

■ DESCRIPTION

The UTC **3NM70** is an Super Junction MOSFET Structure and is designed to have better characteristics, such as fast switching time, low gate charge, low on-state resistance and high rugged avalanche characteristics. This power MOSFET is usually used at high speed switching applications in power supplies, PWM motor controls, high efficient DC to DC converters and bridge circuits.

■ FEATURES

- \*  $R_{DS(ON)} < 2.28\Omega @ V_{GS} = 10V, I_D = 1.5A$
- \* Low reverse transfer capacitance
- \* Fast switching capability
- \* Avalanche energy specified
- \* Improved dv/dt capability, high ruggedness

■ SYMBOL

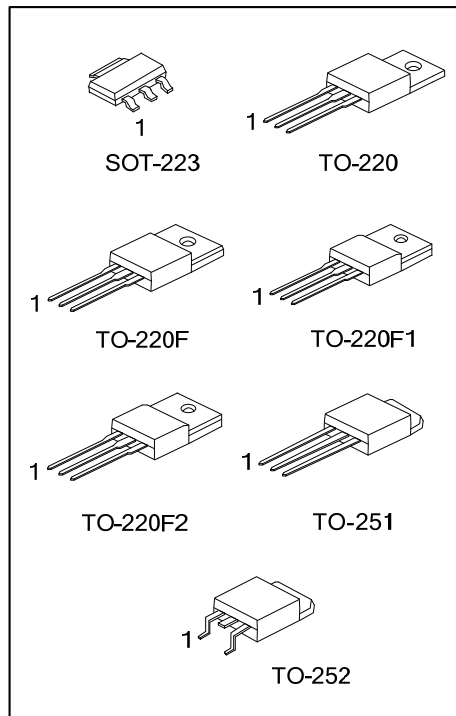
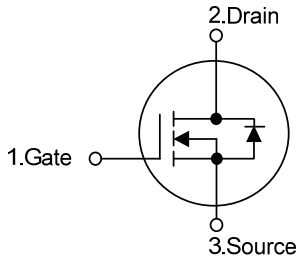

■ ORDERING INFORMATION

Ordering Number		Package	Pin Assignment			Packing
Lead Free	Halogen Free		1	2	3	
-	3NM70G-AA3-T	SOT-223	G	D	S	Tube
3NM70L-TA3-T	3NM70G-TA3-T	TO-220	G	D	S	Tube
3NM70L-TF1-T	3NM70G-TF1-T	TO-220F1	G	D	S	Tube
3NM70L-TF2-T	3NM70G-TF2-T	TO-220F2	G	D	S	Tube
3NM70L-TF3-T	3NM70G-TF3-T	TO-220F	G	D	S	Tube
3NM70L-TM3-T	3NM70G-TM3-T	TO-251	G	D	S	Tube
3NM70L-TN3-R	3NM70G-TN3-R	TO-252	G	D	S	Tape Reel

Note: Pin Assignment: G: Gate D: Drain S: Source

<p>3NM70G-AA3-R</p>	<p>(1) T: Tube, R: Tape Reel                  (2) AA3: SOT-223, TA3: TO-220, TF3: TO-220F, TF1: TO-220F1, TF2: TO-220F2, TM3: TO-251, TN3: TO-252                  (3) L: Lead Free, G: Halogen Free and Lead Free</p>
---------------------	--

■ MARKING

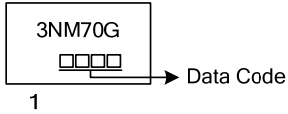
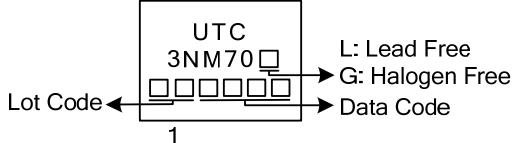
SOT-223	TO-220 / TO-220F / TO-220F1 TO-220F2 / TO-251 / TO-252
 <p>3NM70G □□□ → Data Code 1</p>	 <p>UTC 3NM70 □ □□□□□ ← Lot Code □□□ → Data Code 1</p> <p>L: Lead Free G: Halogen Free</p>

■ ABSOLUTE MAXIMUM RATINGS ( $T_C = 25^\circ\text{C}$ , unless otherwise specified)

PARAMETER		SYMBOL	RATINGS	UNIT
Drain-Source Voltage		$V_{DSS}$	700	V
Gate-Source Voltage		$V_{GSS}$	$\pm 30$	V
Continuous Drain Current		$I_D$	3.0	A
Pulsed Drain Current (Note 2)		$I_{DM}$	12	A
Avalanche Current (Note 2)		$I_{AR}$	1.6	A
Avalanche Energy	Single Pulsed (Note 3)	$E_{AS}$	13	mJ
Peak Diode Recovery dv/dt (Note 4)		dv/dt	5.0	V/ns
Power Dissipation	SOT-223	$P_D$	10	W
	TO-220		78	W
	TO-220F/TO-220F1		34	W
	TO-220F2		35	W
	TO-251/TO-252		50	W
Junction Temperature		$T_J$	+150	$^\circ\text{C}$
Storage Temperature		$T_{STG}$	-55 ~ +150	$^\circ\text{C}$

Notes: 1. Absolute maximum ratings are those values beyond which the device could be permanently damaged.

Absolute maximum ratings are stress ratings only and functional device operation is not implied.

2. Repetitive Rating: Pulse width limited by maximum junction temperature.

3.  $L = 10\text{mH}$ ,  $I_{AS} = 1.6\text{A}$ ,  $V_{DD} = 50\text{V}$ ,  $R_G = 25\ \Omega$ , Starting  $T_J = 25^\circ\text{C}$

4.  $I_{SD} \leq 3.0\text{A}$ ,  $di/dt \leq 200\text{A}/\mu\text{s}$ ,  $V_{DD} \leq BV_{DSS}$ , Starting  $T_J = 25^\circ\text{C}$

■ THERMAL DATA

PARAMETER		SYMBOL	RATINGS	UNIT
Junction to Ambient	SOT-223	$\theta_{JA}$	150	$^\circ\text{C}/\text{W}$
	TO-220/TO-220F		62.5	$^\circ\text{C}/\text{W}$
	TO-220F1/TO-220F2			
	TO-251/TO-252		110	$^\circ\text{C}/\text{W}$
Junction to Case	SOT-223	$\theta_{JC}$	12.5	$^\circ\text{C}/\text{W}$
	TO-220		1.6	$^\circ\text{C}/\text{W}$
	TO-220F/TO-220F1		3.68	$^\circ\text{C}/\text{W}$
	TO-220F2		3.58	$^\circ\text{C}/\text{W}$
	TO-251/TO-252		2.5	$^\circ\text{C}/\text{W}$

■ ELECTRICAL CHARACTERISTICS ( $T_J=25^\circ\text{C}$ , unless otherwise specified)

PARAMETER		SYMBOL	TEST CONDITIONS	MIN	TYP	MAX	UNIT
<b>OFF CHARACTERISTICS</b>							
Drain-Source Breakdown Voltage		$BV_{DSS}$	$V_{GS} = 0\text{ V}, I_D = 250\mu\text{A}$	700			V
Drain-Source Leakage Current		$I_{DSS}$	$V_{DS} = 700\text{ V}, V_{GS} = 0\text{ V}$			10	$\mu\text{A}$
Gate-Source Leakage Current	Forward	$I_{GSS}$	$V_{GS} = 30\text{ V}, V_{DS} = 0\text{ V}$			100	nA
	Reverse		$V_{GS} = -30\text{ V}, V_{DS} = 0\text{ V}$			-100	nA
<b>ON CHARACTERISTICS</b>							
Gate Threshold Voltage		$V_{GS(TH)}$	$V_{DS} = V_{GS}, I_D = 250\mu\text{A}$	2.5		4.5	V
Static Drain-Source On-State Resistance		$R_{DS(ON)}$	$V_{GS} = 10\text{ V}, I_D = 1.5\text{A}$			2.28	$\Omega$
<b>DYNAMIC CHARACTERISTICS</b>							
Input Capacitance		$C_{ISS}$	$V_{GS}=0\text{V}, V_{DS}=25\text{V}, f=1\text{MHz}$		146		pF
Output Capacitance		$C_{OSS}$			131		pF
Reverse Transfer Capacitance		$C_{RSS}$			16		pF
<b>SWITCHING CHARACTERISTICS</b>							
Total Gate Charge (Note 1)		$Q_G$	$V_{DS}=50\text{V}, V_{GS}=10\text{V}, I_D=1.3\text{A}, I_D=100\mu\text{A}$ (Note 1, 2)		37		nC
Gate to Source Charge		$Q_{GS}$			5.2		nC
Gate to Drain Charge		$Q_{GD}$			6.4		nC
Turn-ON Delay Time (Note 1)		$t_{D(ON)}$	$V_{DS}=30\text{V}, V_{GS}=10\text{V}, I_D=0.5\text{A}, R_G=25\Omega$ (Note 1, 2)		32		ns
Rise Time		$t_R$			59		ns
Turn-OFF Delay Time		$t_{D(OFF)}$			104		ns
Fall-Time		$t_F$			36		ns
<b>SOURCE- DRAIN DIODE RATINGS AND CHARACTERISTICS</b>							
Maximum Body-Diode Continuous Current		$I_S$				3.0	A
Maximum Body-Diode Pulsed Current		$I_{SM}$				12	A
Drain-Source Diode Forward Voltage (Note 1)		$V_{SD}$	$I_S=3.0\text{A}, V_{GS}=0\text{V}$			1.4	V
Body Diode Reverse Recovery Time (Note 1)		$t_{rr}$	$I_S=3.0\text{A}, V_{GS}=0\text{V},$		258		ns
Body Diode Reverse Recovery Charge		$Q_{rr}$	$dI_F/dt=100\text{A}/\mu\text{s}$		1.6		$\mu\text{C}$

Notes: 1. Pulse Test: Pulse width  $\leq 300\mu\text{s}$ , Duty cycle  $\leq 2\%$   
 2. Essentially independent of operating temperature

■ TEST CIRCUITS AND WAVEFORMS

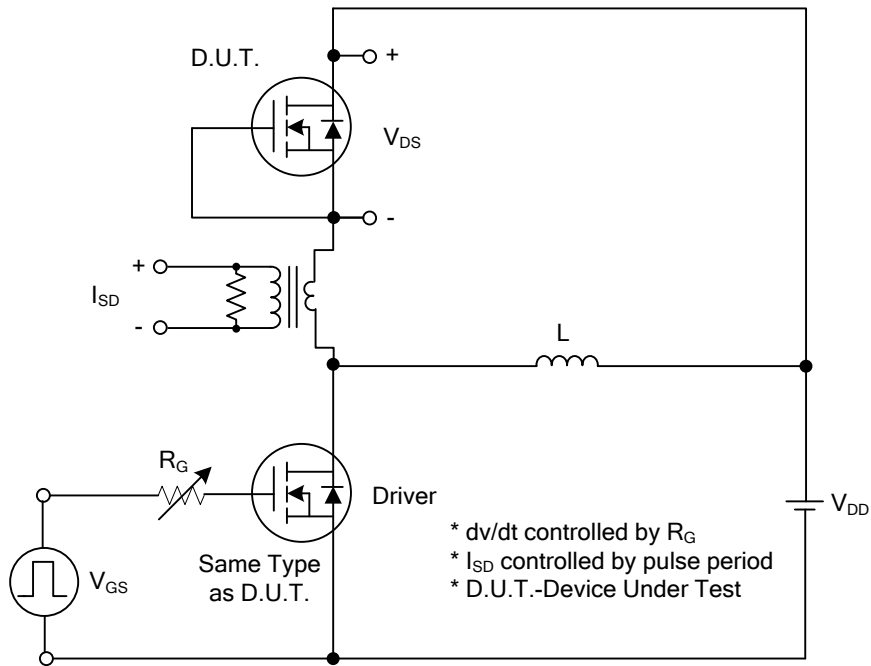

Peak Diode Recovery dv/dt Test Circuit

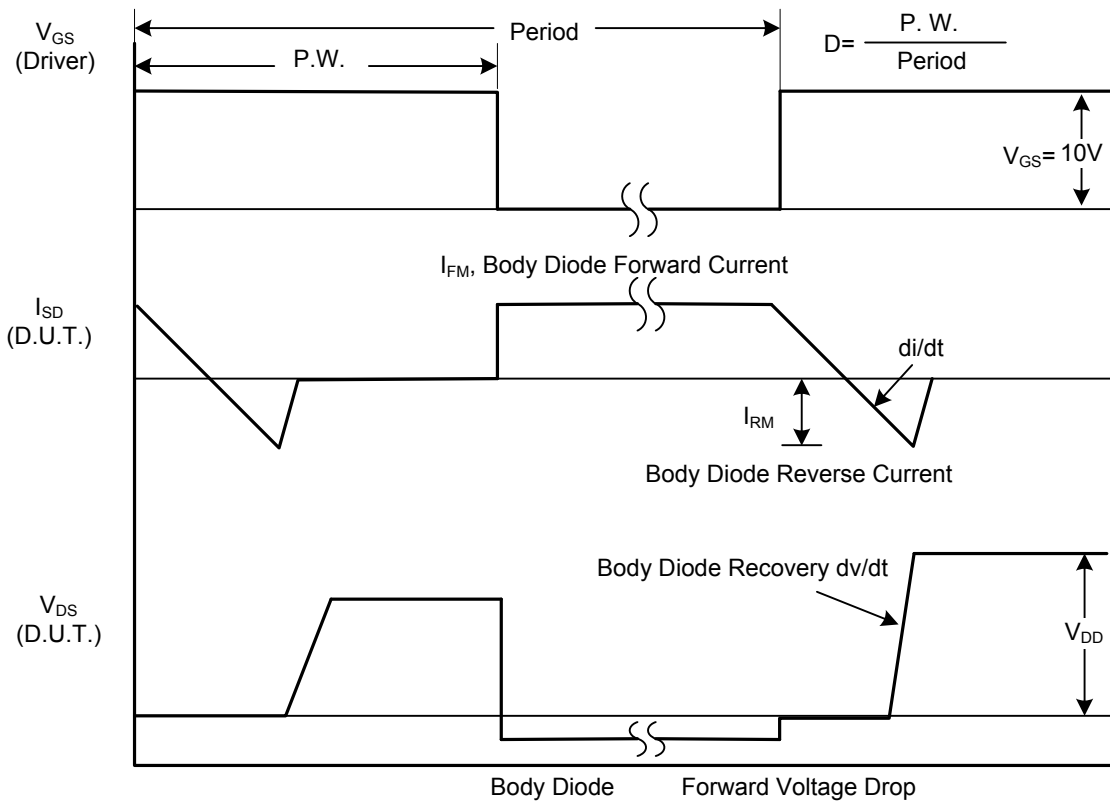

Peak Diode Recovery dv/dt Waveforms

■ TEST CIRCUITS AND WAVEFORMS (Cont.)

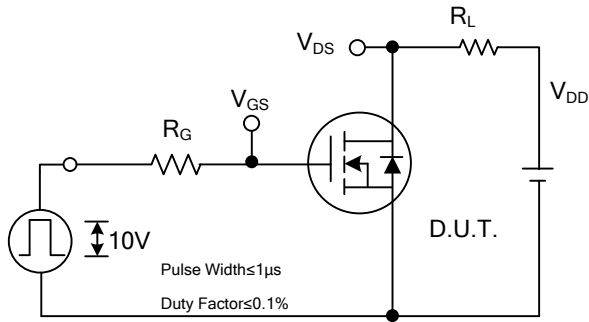

Switching Test Circuit

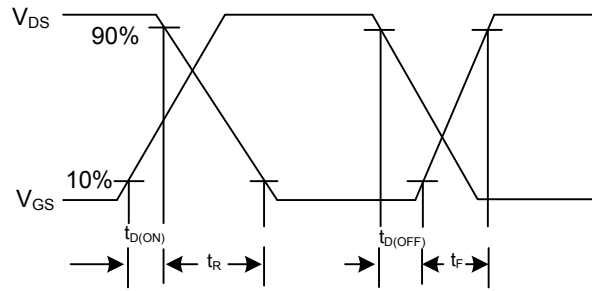

Switching Waveforms

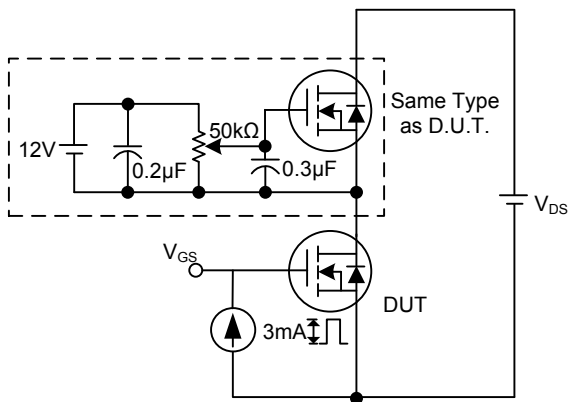

Gate Charge Test Circuit

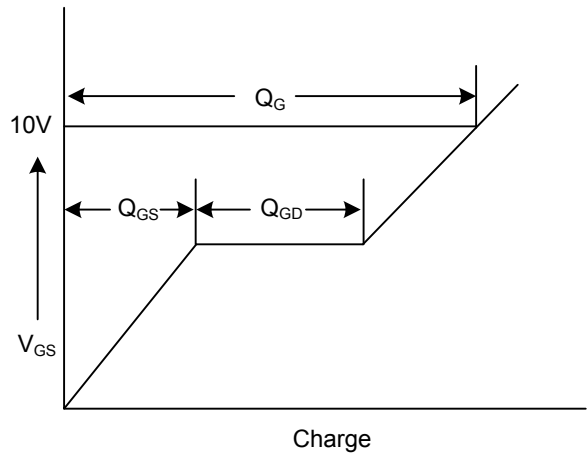

Gate Charge Waveform

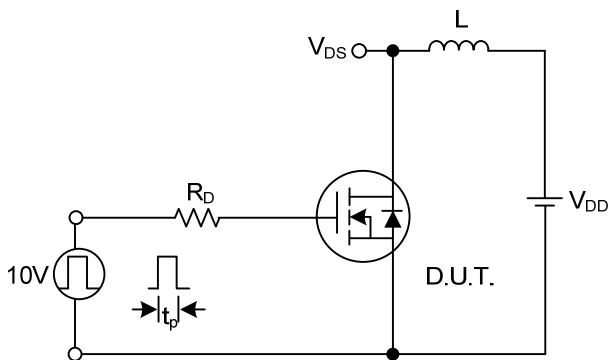

Unclamped Inductive Switching Test Circuit

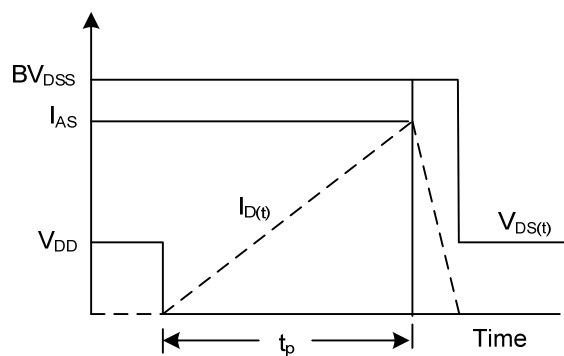

Unclamped Inductive Switching Waveforms

UTC assumes no responsibility for equipment failures that result from using products at values that exceed, even momentarily, rated values (such as maximum ratings, operating condition ranges, or other parameters) listed in products specifications of any and all UTC products described or contained herein. UTC products are not designed for use in life support appliances, devices or systems where malfunction of these products can be reasonably expected to result in personal injury. Reproduction in whole or in part is prohibited without the prior written consent of the copyright owner. The information presented in this document does not form part of any quotation or contract, is believed to be accurate and reliable and may be changed without notice.