



LR9272

Preliminary

CMOS IC

SUPER LOW ON RESISTANCE / LOW VOLTAGE 1A LDO

DESCRIPTION

The UTC **LR9272** is a typical LDO (linear regulator) with the features of high output voltage accuracy, low supply current, low ON-resistance, super low dropout, 1A output current capability, and high ripple rejection.

During operation of the UTC **LR9272**, the dropout voltage is very low, Even the output voltage is set at 1.5V, on resistance of internal FET is typically 0.32Ω. Therefore, applications that require a large current at small dropout are suitable for the UTC **LR9272** series. Low input voltage is acceptable and low output voltage can be set. The minimum input voltage is 1.4V, and the lowest set output voltage is 0.8V, and the response of line transient and load transient are very well.

Internally, there're many functions of UTC **LR9272** which can be seen in the block figure. There are a voltage reference unit, an error amplifier, resistor-net for voltage setting, a current limit circuit, and a chip enable circuit in each UTC **LR9272**.

The UTC **LR9272** can be used as an ideal of the power supply for hand-held communication equipment, such as: power source for portable communication equipment, power source for electrical appliances, for example, cameras, VCRs and camcorders and power source for battery-powered equipment.

FEATURES

- * Low standby current (TYP=0.1μA)
- * Ultra-Low supply current (TYP=60μA)
- * Output current (MIN=1A@VIN=VOUT+1.0V)
- * Output voltage accuracy (±2.0%)
- * Input voltage range (1.4V~6.0V)
- * Output voltage (0.8V~5.0V)
- * Dropout voltage (TYP=0.18V@VOUT=3.0V, IOUT=1A)
- * Ripple rejection (TYP=70dB @ VOUT=3.0V)
- * Line regulation (TYP=0.05%/V)
- * Low temperature-drift coefficient of output voltage
- * Built-in thermal shutdown circuit
- * Built-in inrush current limit circuit
- * Built-in fold-back protection circuit
- * Built-in auto discharge function

ORDERING INFORMATION

Ordering Number	Package	Pin Assignment				Packing
		Pin Code	1	2	3	
LR9272G-xx-AA3-C-R	SOT-223	C	G	I	O	Tape Reel
LR9272G-xx-AF5-R	SOT-25	Refer to PIN CONFIGURATION				Tape Reel

Note: xx: Output Voltage, refer to Marking Information.

<p>LR9272xG-xx-AA3-C-R</p> <p>(1)Packing Type (2)Pin Assignment (3)Package Type (4)Output Voltage Code (5)Green Package (6)Discharge Function</p>	<p>(1) R: Tape Reel (2) refer to Pin Assignment (3) AA3: SOT-223, AF5: SOT-25 (4) xx: refer to Marking Information (5) G: Halogen Free and Lead Free (6) A: "L" active, without auto discharge function at off state B: "H" active, without auto discharge function at off state</p>
---	--

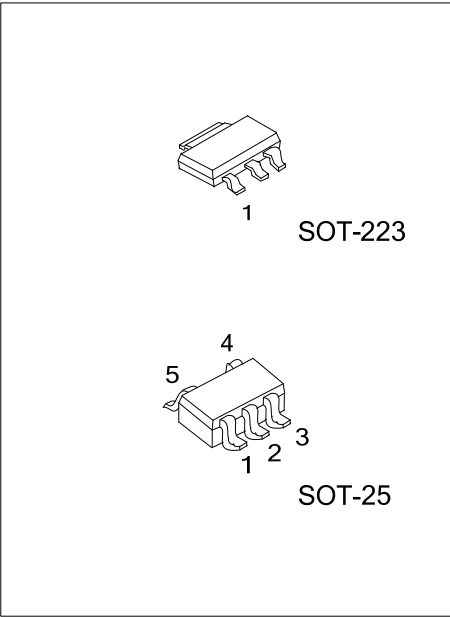

MARKING INFORMATION

PACKAGE	VOLTAGE CODE	MARKING
SOT-223	25: 2.5V 33: 3.3V 50: 5.0V	
SOT-25		

PIN CONFIGURATION(For SOT-25)

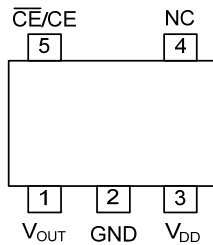

PIN DESCRIPTION(For SOT-25)

PIN NO.	PIN NAME	DESCRIPTION
1	V _{OUT}	Voltage regulator output pin
2	GND	Ground pin
3	V _{DD}	Input pin
4	NC	No connection
5	$\overline{\text{CE}}$ or CE	Chip enable pin

■ BLOCK DIAGRAM

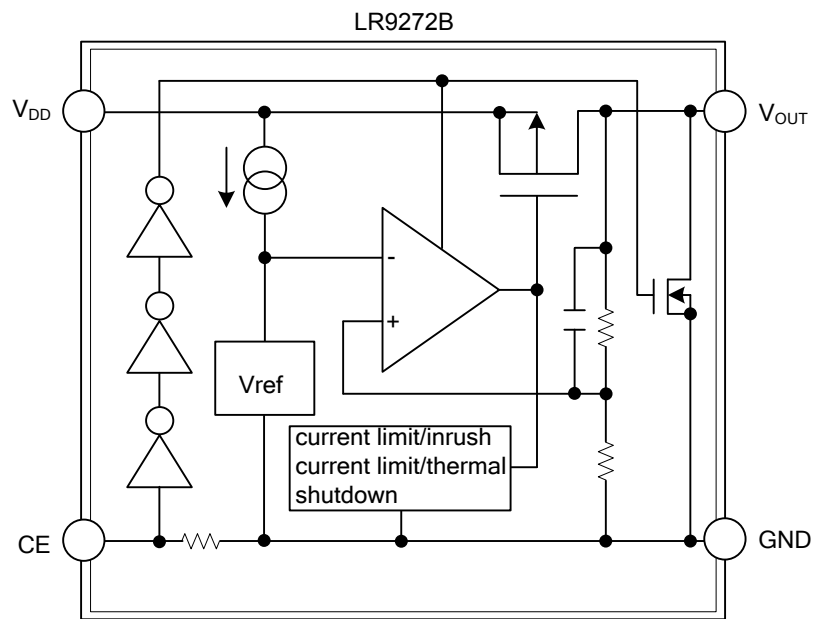
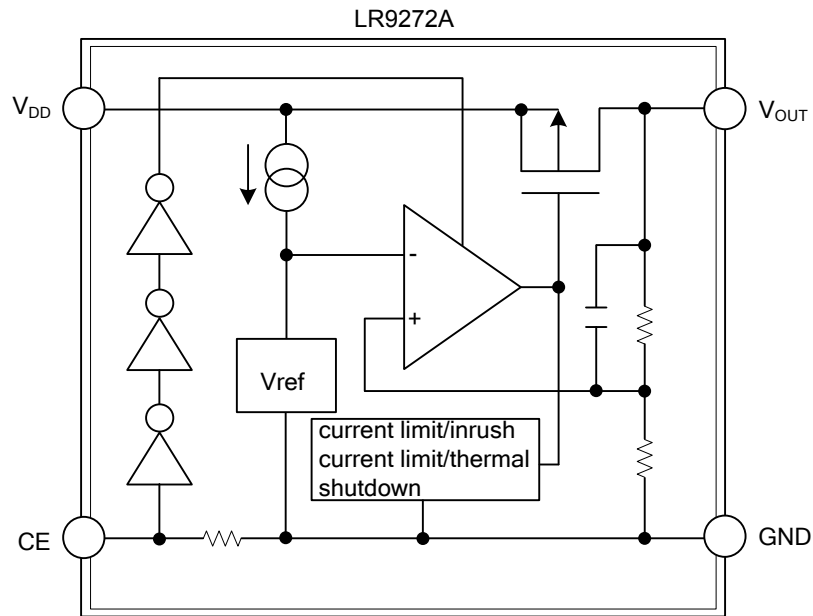

■ ABSOLUTE MAXIMUM RATING (T_A= 25°C, unless otherwise specified)

PARAMETER	SYMBOL	RATINGS	UNIT
Input Voltage	V _{IN}	6.5	V
Input Voltage(CE or CE Input Pin)	V _{CE}	-0.3~6.5	V
Output Voltage	V _{OUT}	-0.3~V _{IN} +0.3	V
Power Dissipation	P _D	420	mW
Operating Temperature	T _{OPT}	-40~85	°C
Storage Temperature	T _{STG}	-55~125	°C

Note: Absolute maximum ratings are those values beyond which the device could be permanently damaged. Absolute maximum ratings are stress ratings only and functional device operation is not implied.

■ ELECTRICAL CHARACTERISTICS (T_A= 25°C, unless otherwise specified)

LR9272A/B-xx

PARAMETER	SYMBOL	TEST CONDITIONS	MIN	TYP	MAX	UNIT
Input Voltage	V _{IN}		1.4		6.0	V
Supply Current	I _{SS}	V _{IN} -V _{OUT} =1.0V, V _{IN} =V _{CE} , I _{OUT} =0A		60	100	μA
Standby Current	I _{STB}	V _{IN} =6.0V, V _{CE} =0V		0.1	1.0	μA
Output Voltage	V _{OUT}	V _{IN} -V _{OUT} =1.0V, V _{OUT} >1.5V	x0.98		x1.02	V
		I _{OUT} =100mA, V _{OUT} ≤1.5V	-30		+30	mV
Load Regulation	ΔV _{OUT} /ΔI _{OUT}	V _{IN} -V _{OUT} =0.3V, 1mA≤I _{OUT} ≤300mA, If V _{OUT} ≤1.1V, then V _{IN} =1.4V	-15	15	30	mV
		V _{IN} -V _{OUT} =0.3V, 1mA≤I _{OUT} ≤1A, If V _{OUT} ≤1.1V, then V _{IN} =1.7V		50		mV
Dropout Voltage	V _{DIF}	0.8≤V _{OUT} <0.9	I _{OUT} =300mA	0.33	0.57	V
			I _{OUT} =1A	0.72		V
		0.9≤V _{OUT} <1.0	I _{OUT} =300mA	0.22	0.47	V
			I _{OUT} =1A	0.64		V
		1.0≤V _{OUT} <1.5	I _{OUT} =300mA	0.18	0.32	V
			I _{OUT} =1A	0.56		V
		1.5≤V _{OUT} <2.6	I _{OUT} =300mA	0.10	0.15	V
			I _{OUT} =1A	0.32		V
2.6≤V _{OUT}	I _{OUT} =300mA	0.05	0.10	V		
	I _{OUT} =1A	0.18		V		
Line Regulation	ΔV _{OUT} /ΔV _{IN}	I _{OUT} =100mA, V _{OUT} +0.5V≤V _{IN} ≤6.0V, If V _{OUT} ≤0.9V, 1.4V≤V _{IN} ≤6.0V		0.05	0.20	%/V
Ripple Rejection	RR	f=1kHz, (V _{OUT} ≤4.0V)		70		dB
		f=1kHz, (V _{OUT} >4.0V), Ripple 0.5Vp-p, V _{IN} -V _{OUT} =1.0V, I _{OUT} =100mA, If V _{OUT} ≤1.2V, V _{IN} -V _{OUT} =1.5V, I _{OUT} =100mA		60		dB
Output Voltage Temperature Coefficient	ΔV _{OUT} /ΔT _{OPT}	I _{OUT} =100mA, -40°C≤T _{OPT} ≤85°C		±100		ppm/°C
Output Current	I _{LIM}	V _{IN} -V _{OUT} =1.0V		1		A
Short Current Limit	I _{SC}	V _{OUT} =0V		500		mA
Pull-Down resistance for CE pin	R _{PD}		1.9	5.0	15.0	MΩ
CE Input Voltage "H"	V _{CEH}		1.0		6.0	V
CE Input Voltage "L"	V _{CEL}		0		0.4	V
Thermal Shutdown Temperature	T _{TSD}	Junction Temperature		150		°C
Thermal Shutdown Released Temperature	T _{TSR}	Junction Temperature		120		°C
Output Noise	en	BW=10Hz~100kHz		30		μVrms

■ TYPICAL APPLICATION CIRCUIT

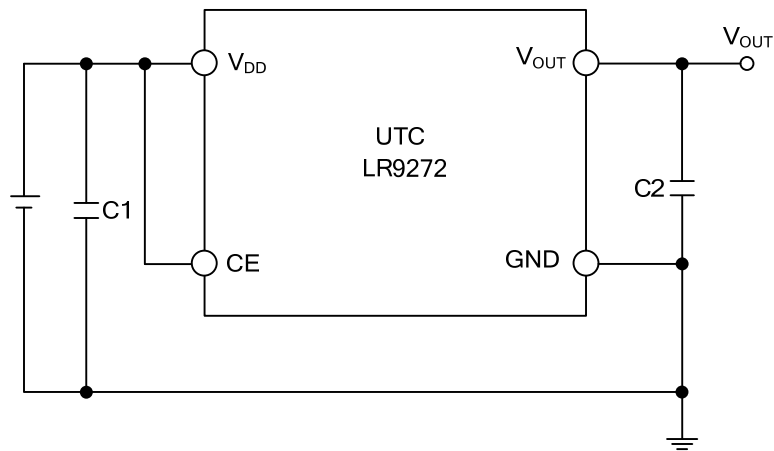

UTC assumes no responsibility for equipment failures that result from using products at values that exceed, even momentarily, rated values (such as maximum ratings, operating condition ranges, or other parameters) listed in products specifications of any and all UTC products described or contained herein. UTC products are not designed for use in life support appliances, devices or systems where malfunction of these products can be reasonably expected to result in personal injury. Reproduction in whole or in part is prohibited without the prior written consent of the copyright owner. The information presented in this document does not form part of any quotation or contract, is believed to be accurate and reliable and may be changed without notice.