



UTT15N10

Power MOSFET

15A, 100V N-CHANNEL POWER MOSFET

■ **DESCRIPTION**

The UTC **UTT15N10** uses UTC's advanced proprietary, planar stripe, DMOS technology to provide excellent $R_{DS(ON)}$, low gate charge and operation with low gate voltages. This device is suitable for use as high current switching applications.

■ **FEATURES**

- * $R_{DS(ON)} \leq 125 \text{ m}\Omega @ V_{GS}=10\text{V}, I_D=7.5\text{A}$
- * $R_{DS(ON)} \leq 150 \text{ m}\Omega @ V_{GS}=4.5\text{V}, I_D=7.5\text{A}$
- * Low on-state resistance
- * Built-in gate protection diode
- * High Switching Speed
- * High Power and Current Handling Capability

■ **SYMBOL**

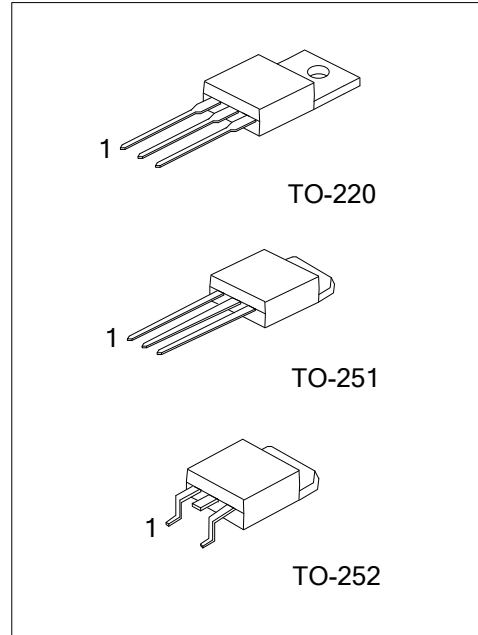
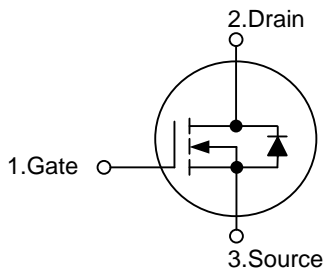

■ **ORDERING INFORMATION**

Ordering Number		Package	Pin Assignment			Packing
Lead Free	Halogen Free		1	2	3	
UTT15N10L-TA3-T	UTT15N10G-TA3-T	TO-220	G	D	S	Tube
UTT15N10L-TM3-T	UTT15N10G-TM3-T	TO-251	G	D	S	Tube
UTT15N10L-TN3-R	UTT15N10G-TN3-R	TO-252	G	D	S	Tape Reel

Note: Pin Assignment: G: Gate D: Drain S: Source

<p>UTT15N10G-TA3-T</p> <p>(1)Packing Type (2)Package Type (3)Green Package</p>	<p>(1) T: Tube, R: Tape Reel (2) TA3: TO-220, TM3: TO-251, TN3: TO-252 (3) G: Halogen Free and Lead Free, , L: Lead Free</p>
--	--

■ **MARKING**

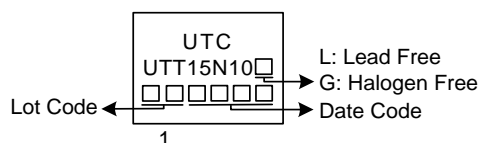

■ ABSOLUTE MAXIMUM RATINGS (T_C =25°C, unless otherwise specified)

PARAMETER		SYMBOL	RATINGS	UNIT
Drain-Source Voltage		V _{DSS}	100	V
Gate-Source Voltage		V _{GSS}	±20	V
Continuous Drain Current		I _D	15	A
Avalanche Energy	Single Pulsed	E _{AS}	10	mJ
Peak Diode Recovery dv/dt		dv/dt	10	V/ns
Power Dissipation	TO-220	P _D	90	W
	TO-251/TO-252		34.7	W
Junction Temperature		T _J	+150	°C
Storage Temperature		T _{STG}	-55 ~ +150	°C

Notes: 1. Absolute maximum ratings are those values beyond which the device could be permanently damaged.

Absolute maximum ratings are stress ratings only and functional device operation is not implied.

2. Repetitive Rating: Pulse width limited by maximum junction temperature.
3. L=0.08mH, I_{AS}=15A, V_{DD}=50V, R_G=25Ω, Starting T_J=25°C
4. I_{SD} ≤ 7A, di/dt ≤ 200A/μs, V_{DD} ≤ BV_{DSS}, Starting T_J = 25°C

■ THERMAL DATA

PARAMETER		SYMBOL	RATINGS	UNIT
Junction to Ambient	TO-220	θ _{JA}	62.5	°C/W
	TO-251/TO-252		125	°C/W
Junction to Case	TO-220	θ _{JC}	1.38	°C/W
	TO-251/TO-252		4.17	°C/W

■ ELECTRICAL CHARACTERISTICS (T_J =25°C, unless otherwise specified)

PARAMETER	SYMBOL	TEST CONDITIONS	MIN	TYP	MAX	UNIT
OFF CHARACTERISTICS						
Drain-Source Breakdown Voltage	BV _{DSS}	V _{GS} =0V, I _D =250μA	100			V
Drain-Source Leakage Current	I _{DSS}	V _{DS} =100V, V _{GS} =0V			10	μA
Gate-Body Leakage Current	I _{GSS}	V _{DS} =0V, V _{GS} =±20V			±10	μA
ON CHARACTERISTICS						
Gate Threshold Voltage	V _{GS(TH)}	V _{DS} =10V, I _D =1mA	1.0		3.0	V
Static Drain-Source On-Resistance	R _{DS(ON)}	V _{GS} =10V, I _D =7.5A		110	125	mΩ
		V _{GS} =4.5V, I _D =7.5A		135	150	mΩ
DYNAMIC PARAMETERS						
Input Capacitance	C _{ISS}	V _{DS} =25V, V _{GS} =0V, f=1MHz		920		pF
Output Capacitance	C _{OSS}			55		pF
Reverse Transfer Capacitance	C _{RSS}			46		pF
SWITCHING PARAMETERS						
Total Gate Charge	Q _G	V _{GS} =10V, V _{DD} =80V, I _D =15A		20		nC
Gate Source Charge	Q _{GS}			3		nC
Gate Drain Charge	Q _{GD}			5		nC
Turn-ON Delay Time	t _{D(ON)}	V _{GS} =10V, V _{DS} =30V, I _D =7.5A R _G =25Ω		9		ns
Turn-ON Rise Time	t _R			5		ns
Turn-OFF Delay Time	t _{D(OFF)}			30		ns
Turn-OFF Fall-Time	t _F			4		ns
SOURCE- DRAIN DIODE RATINGS AND CHARACTERISTICS						
Maximum Continuous Drain-Source Diode Forward Current	I _S	V _{GS} =0V		15		A
Maximum Pulsed Drain-Source Diode Forward Current	I _{SM}	Repetitive		60		A
Drain-Source Diode Forward Voltage	V _{SD}	I _F =16A, V _{GS} =0V		1.0		V

Notes: 1. Pulse Test : Pulse width ≤ 300μs, Duty cycle ≤ 2%.

2. Essentially independent of operating ambient temperature.

■ TEST CIRCUITS AND WAVEFORMS

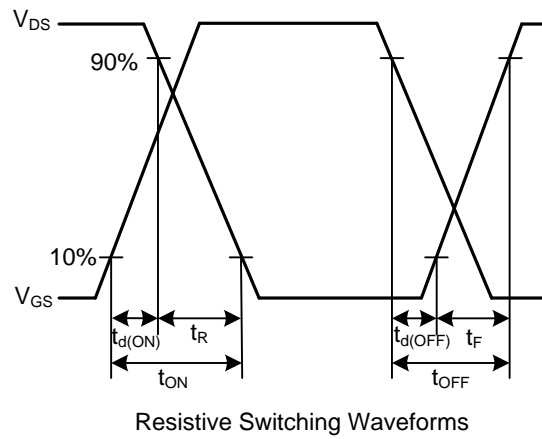
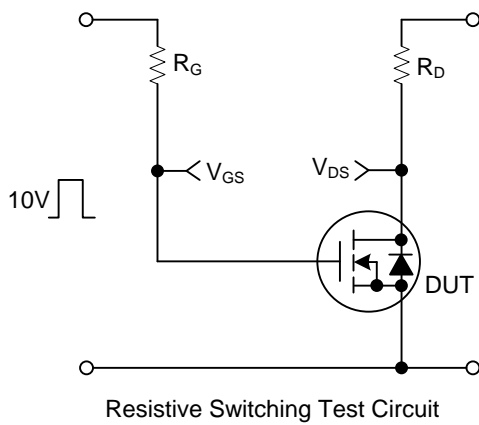
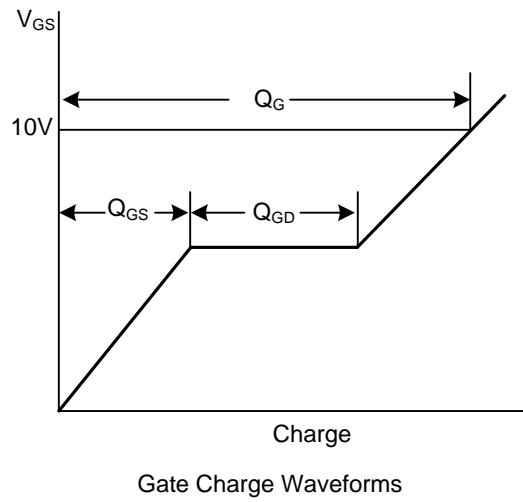
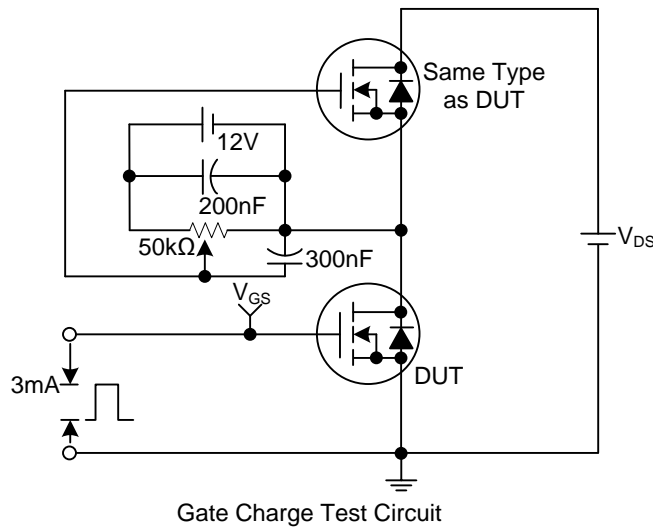

TEST CIRCUITS AND WAVEFORMS

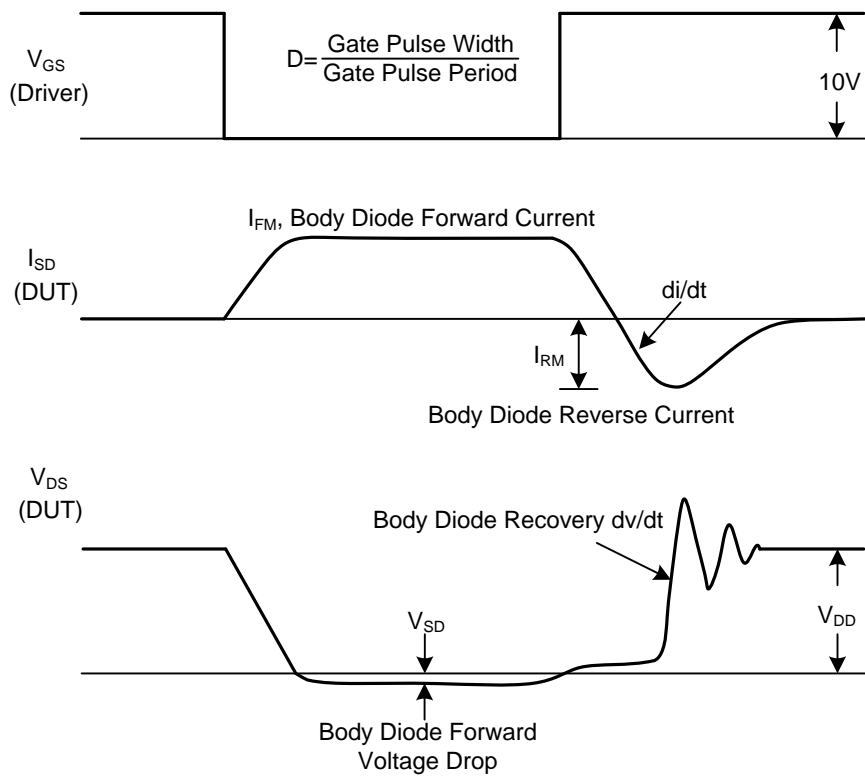
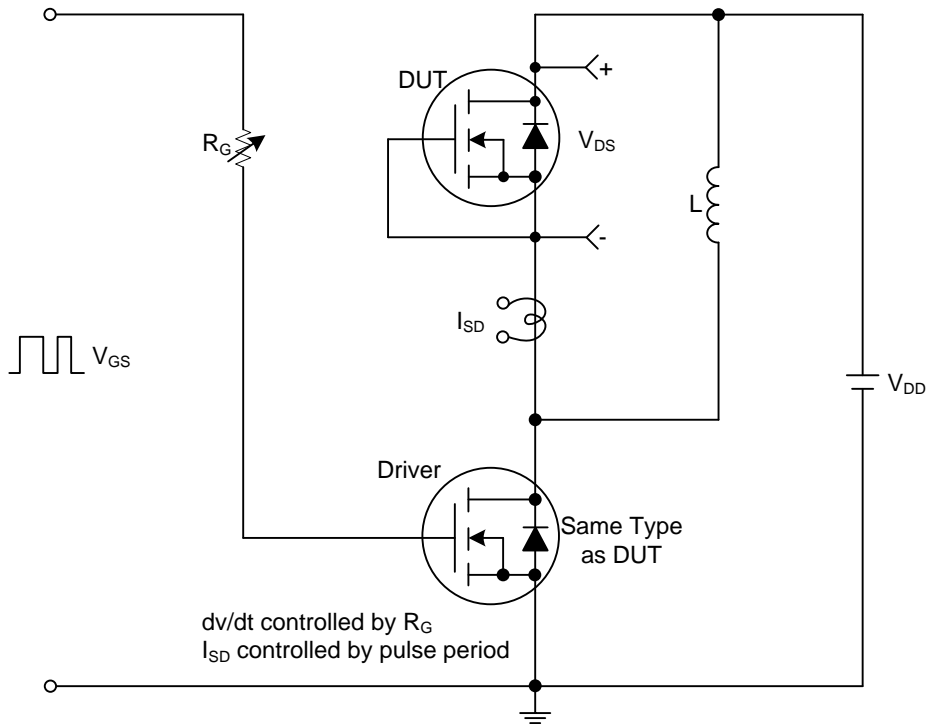

Peak Diode Recovery dv/dt Test Circuit and Waveforms

■ TYPICAL CHARACTERISTICS

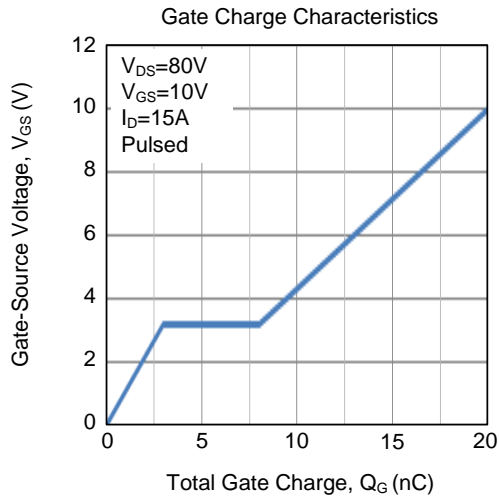

UTC assumes no responsibility for equipment failures that result from using products at values that exceed, even momentarily, rated values (such as maximum ratings, operating condition ranges, or other parameters) listed in products specifications of any and all UTC products described or contained herein. UTC products are not designed for use in life support appliances, devices or systems where malfunction of these products can be reasonably expected to result in personal injury. Reproduction in whole or in part is prohibited without the prior written consent of the copyright owner. UTC reserves the right to make changes to information published in this document, including without limitation specifications and product descriptions, at any time and without notice. This document supersedes and replaces all information supplied prior to the publication hereof.