



# 6N70K-MTQ

Power MOSFET

## 6.0A, 700V N-CHANNEL POWER MOSFET

### DESCRIPTION

The UTC **6N70K-MTQ** is an N-channel mode power MOSFET using UTC's advanced technology to provide customers with a minimum on-state resistance, high switching speed, low gate charge and low input capacitance.

The UTC **6N70K-MTQ** is universally applied in high efficiency switch mode power supply.

### FEATURES

- \*  $R_{DS(ON)} < 2.4\Omega$  @  $V_{GS} = 10V$ ,  $I_D = 3A$
- \* High switching speed

### SYMBOL

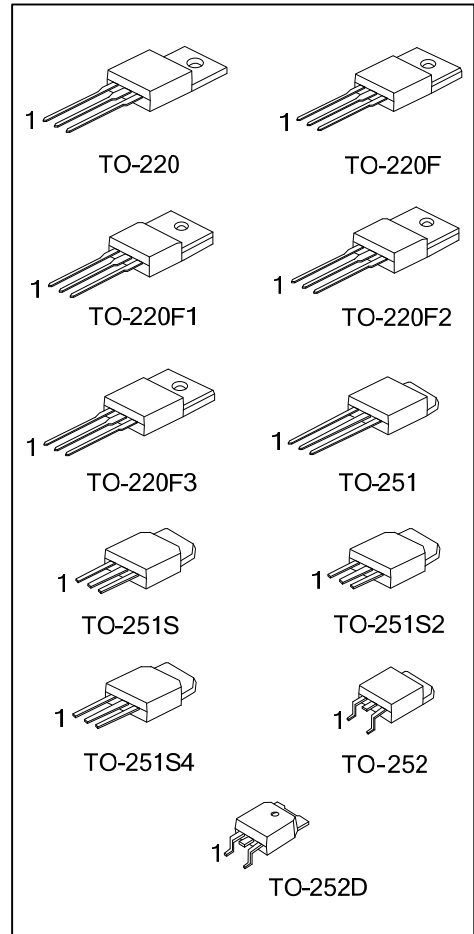
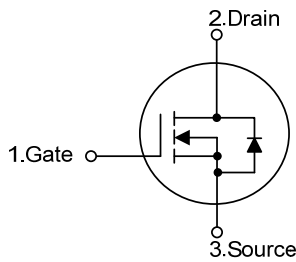

### ORDERING INFORMATION

Ordering Number		Package	Pin Assignment			Packing
Lead Free	Halogen Free		1	2	3	
6N70KL-TA3-T	6N70KG-TA3-T	TO-220	G	D	S	Tube
6N70KL-TF3-T	6N70KG-TF3-T	TO-220F	G	D	S	Tube
6N70KL-TF1-T	6N70KG-TF1-T	TO-220F1	G	D	S	Tube
6N70KL-TF2-T	6N70KG-TF2-T	TO-220F2	G	D	S	Tube
6N70KL-TF3-T	6N70KG-TF3-T	TO-220F3	G	D	S	Tube
6N70KL-TM3-T	6N70KG-TM3-T	TO-251	G	D	S	Tube
6N70KL-TMS-T	6N70KG-TMS-T	TO-251S	G	D	S	Tube
6N70KL-TMS2-T	6N70KG-TMS2-T	TO-251S2	G	D	S	Tube
6N70KL-TMS4-T	6N70KG-TMS4-T	TO-251S4	G	D	S	Tube
6N70KL-TN3-R	6N70KG-TN3-R	TO-252	G	D	S	Tape Reel
6N70KL-TND-R	6N70KG-TND-R	TO-252D	G	D	S	Tape Reel

Note: Pin Assignment: G: Gate D: Drain S: Source

<p>6N70KL-TA3-T</p> <p>(1) Packing Type</p> <p>(2) Package Type</p> <p>(3) Green Package</p>	<p>(1) T: Tube, R: Tape Reel</p> <p>(2) TA3: TO-220, TF3: TO-220F, TF1: TO-220F1, TF2: TO-220F2, TF3: TO-220F3, TM3: TO-251 TMS: TO-251S, TMS2: TO-251S2, TMS4: TO-251S4, TN3: TO-252, TND: TO-252D</p> <p>(3) L: Lead Free, G: Halogen Free and Lead Free</p>
--	--

### MARKING

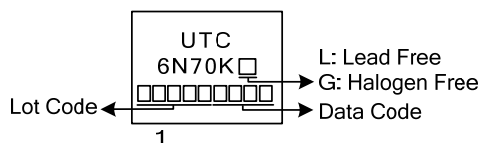

■ ABSOLUTE MAXIMUM RATINGS ( $T_C=25^\circ\text{C}$ , unless otherwise specified)

PARAMETER		SYMBOL	RATINGS	UNIT
Drain-Source Voltage		$V_{DSS}$	700	V
Gate-Source Voltage (Note 2)		$V_{GSS}$	$\pm 30$	V
Drain Current	Continuous $T_C=25^\circ\text{C}$	$I_D$	6	A
	Pulsed	$I_{DM}$	24	A
Avalanche Current (Note 2)		$I_{AR}$	6	A
Avalanche Energy	Single Pulsed (Note 3)	$E_{AS}$	75	mJ
Peak Diode Recovery dv/dt (Note 4)		dv/dt	2.5	V/ns
Power Dissipation	TO-220	$P_D$	125	W
	TO-220F/TO-220F1		42	
	TO-220F2/TO-220F3			
	TO-251/TO-251S		55	
TO-251S2/TO-251S4				
TO-252/TO-252D				
Linear Derating Factor	TO-220			1
	TO-220F		0.32	
	TO-220F1/TO-220F2	0.336		
	TO-220F3			
	TO-251/TO-251S	0.44		
	TO-251S2/TO-251S4			
TO-252/TO-252D				
Junction Temperature		$T_J$	+150	$^\circ\text{C}$
Storage Temperature		$T_{STG}$	-55~+150	$^\circ\text{C}$

Notes: 1. Absolute maximum ratings are those values beyond which the device could be permanently damaged.

Absolute maximum ratings are stress ratings only and functional device operation is not implied.

2. Repetitive Rating: Pulse width limited by maximum junction temperature

3.  $L = 5\text{mH}$ ,  $I_{AS} = 5.5\text{A}$ ,  $V_{DD} = 50\text{V}$ ,  $R_G = 25\Omega$ , Starting  $T_J = 25^\circ\text{C}$

4.  $I_{SD} \leq 6\text{A}$ ,  $di/dt \leq 140\text{A}/\mu\text{s}$ ,  $V_{DD} \leq BV_{DSS}$ , Starting  $T_J = 25^\circ\text{C}$

■ THERMAL DATA

PARAMETER		SYMBOL	RATINGS	UNIT
Junction to Ambient	TO-220/TO-220F	$\theta_{JA}$	62.5	$^\circ\text{C}/\text{W}$
	TO-220F1/TO-220F2			
	TO-220F3			
	TO-251/TO-251S		110	
TO-251S2/TO-251S4				
TO-252/TO-252D				
Junction to Case	TO-220	$\theta_{JC}$	3.1	$^\circ\text{C}/\text{W}$
	TO-220F		1.0	
	TO-220F1/TO-220F2		2.9	
	TO-220F3			
	TO-251/TO-251S		2.27	
	TO-251S2/TO-251S4			
TO-252/TO-252D				

■ ELECTRICAL CHARACTERISTICS ( $T_C=25^\circ\text{C}$ , unless otherwise specified)

PARAMETER		SYMBOL	TEST CONDITIONS	MIN	TYP	MAX	UNIT	
<b>OFF CHARACTERISTICS</b>								
Drain-Source Breakdown Voltage		$BV_{DSS}$	$I_D=250\mu\text{A}$ , $V_{GS}=0\text{V}$	700			V	
Breakdown Voltage Temperature Coefficient		$\Delta BV_{DSS}/\Delta T_J$	$I_D=250\mu\text{A}$		0.79		$\text{V}/^\circ\text{C}$	
Drain-Source Leakage Current		$I_{DSS}$	$V_{DS}=700\text{V}$ , $V_{GS}=0\text{V}$			1	$\mu\text{A}$	
			$V_{DS}=560\text{V}$ , $T_C=125^\circ\text{C}$			250	$\mu\text{A}$	
Gate-Source Leakage Current	Forward	$I_{GSS}$	$V_{GS}=+30\text{V}$ , $V_{DS}=0\text{V}$			+100	nA	
	Reverse		$V_{GS}=-30\text{V}$ , $V_{DS}=0\text{V}$			-100	nA	
<b>ON CHARACTERISTICS</b>								
Gate Threshold Voltage		$V_{GS(TH)}$	$V_{DS}=V_{GS}$ , $I_D=250\mu\text{A}$	2.0		4.0	V	
Static Drain-Source On-State Resistance		$R_{DS(ON)}$	$V_{GS}=10\text{V}$ , $I_D=3\text{A}$ (Note 1)		2.0	2.4	$\Omega$	
<b>DYNAMIC PARAMETERS</b>								
Input Capacitance		$C_{ISS}$	$V_{GS}=0\text{V}$ , $V_{DS}=25\text{V}$ , $f=1.0\text{MHz}$ (Note 1, 2)		480		pF	
Output Capacitance		$C_{OSS}$				65		pF
Reverse Transfer Capacitance		$C_{RSS}$				7.5		pF
<b>SWITCHING PARAMETERS</b>								
Turn-ON Delay Time		$t_{D(ON)}$	$V_{DD}=30\text{V}$ , $I_D=0.5\text{A}$ , $R_G=25\Omega$ $V_{GS}=10\text{V}$		70		ns	
Rise Time		$t_R$				61		ns
Turn-OFF Delay Time		$t_{D(OFF)}$				140		ns
Fall-Time		$t_F$				41		ns
Total Gate Charge		$Q_G$	$V_{GS}=10\text{V}$ , $V_{DS}=50\text{V}$ , $I_D=1.3\text{A}$ , $I_G=100\mu\text{A}$ (Note 1, 2)		45		nC	
Gate to Source Charge		$Q_{GS}$				7		nC
Gate to Drain Charge		$Q_{GD}$				7		nC
<b>SOURCE- DRAIN DIODE RATINGS AND CHARACTERISTICS</b>								
Maximum Body-Diode Continuous Current		$I_S$	Integral reverse pn-diode in the MOSFET			6	A	
Maximum Body-Diode Pulsed Current (Note 3)		$I_{SM}$				24	A	
Drain-Source Diode Forward Voltage (Note 2)		$V_{SD}$	$I_S=6\text{A}$ , $V_{GS}=0\text{V}$ , $T_J = 25^\circ\text{C}$			1.4	V	

- Notes: 1. Pulse Test: Pulse width  $\leq 250\mu\text{s}$ , Duty cycle  $\leq 2\%$   
 2. Essentially independent of operating temperature  
 3. Repetitive Rating: Pulse width limited by maximum junction temperature

## TEST CIRCUITS AND WAVEFORMS

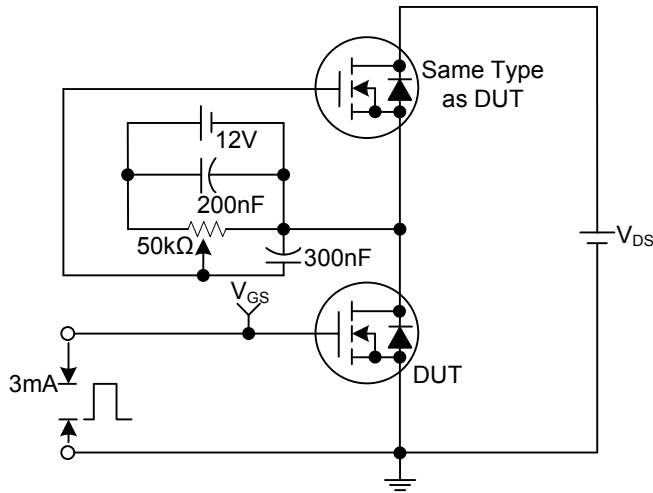

**Gate Charge Test Circuit**

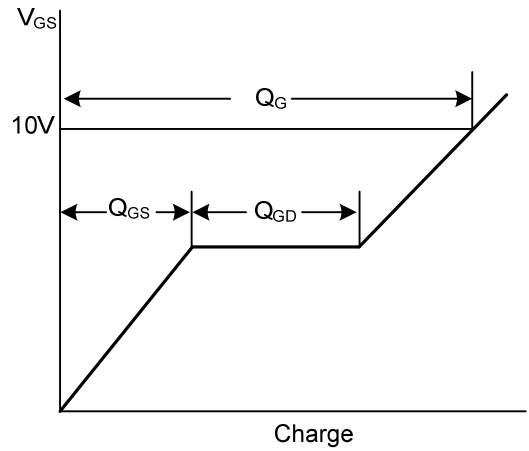

**Gate Charge Waveforms**

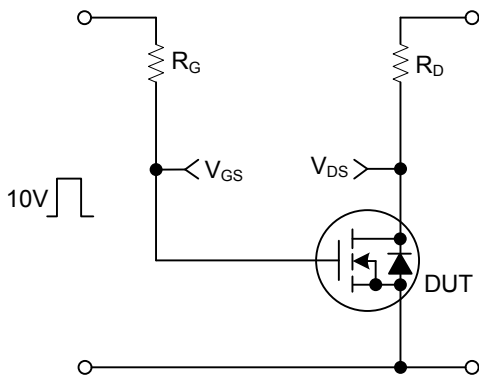

**Resistive Switching Test Circuit**

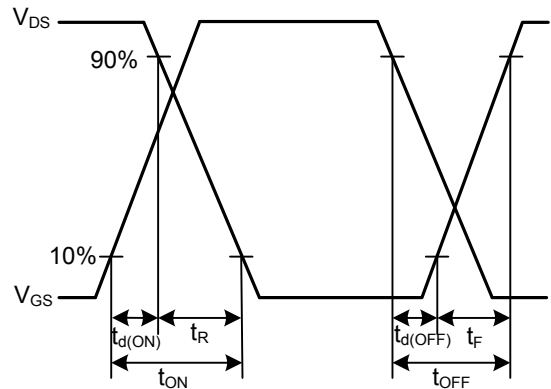

**Resistive Switching Waveforms**

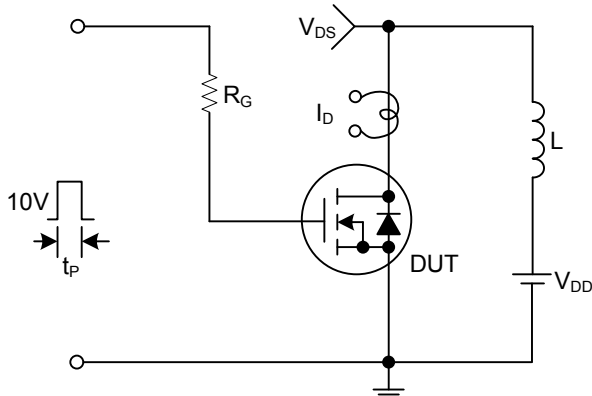

**Unclamped Inductive Switching Test Circuit**

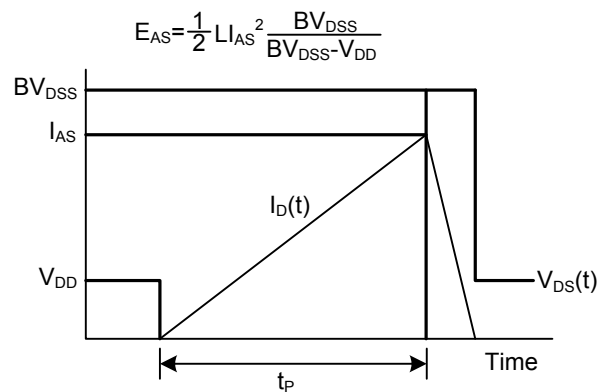

**Unclamped Inductive Switching Waveforms**

## TEST CIRCUITS AND WAVEFORMS(Cont.)

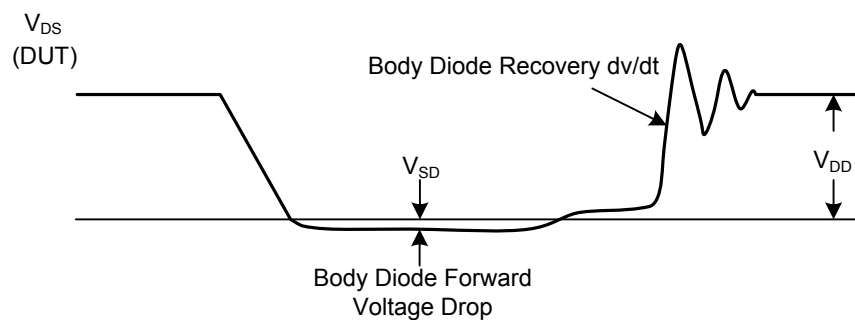
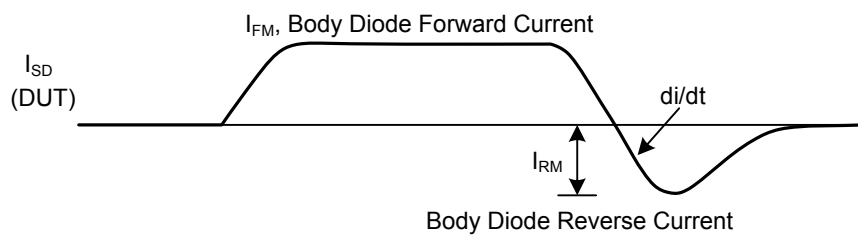
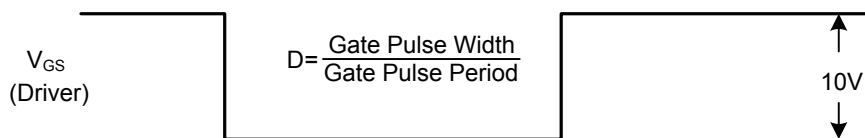
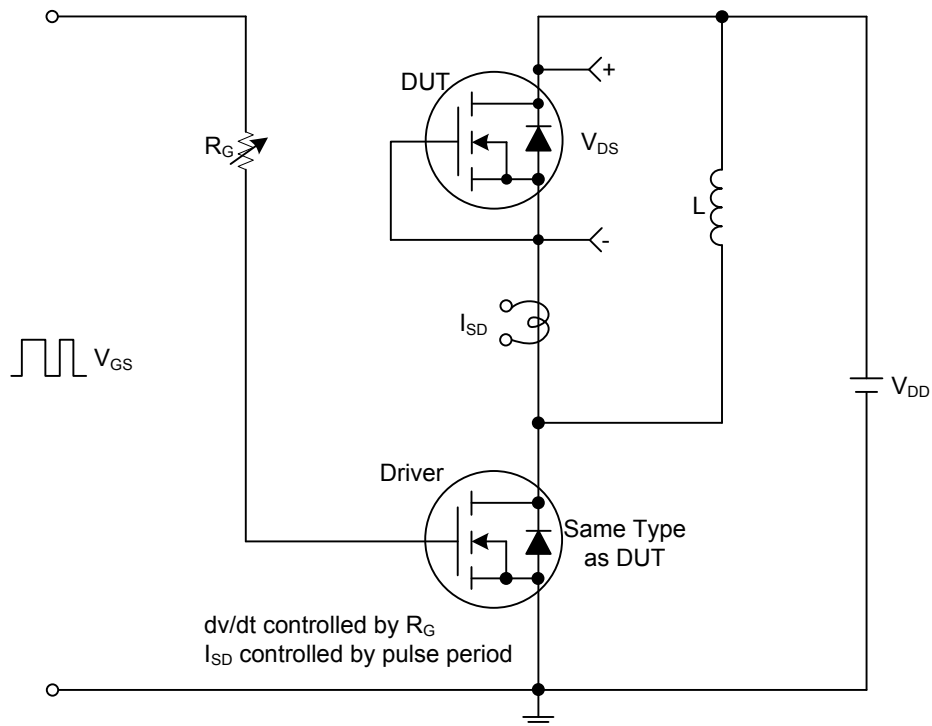

Peak Diode Recovery  $dv/dt$  Test Circuit and Waveforms

## ■ TYPICAL CHARACTERISTICS

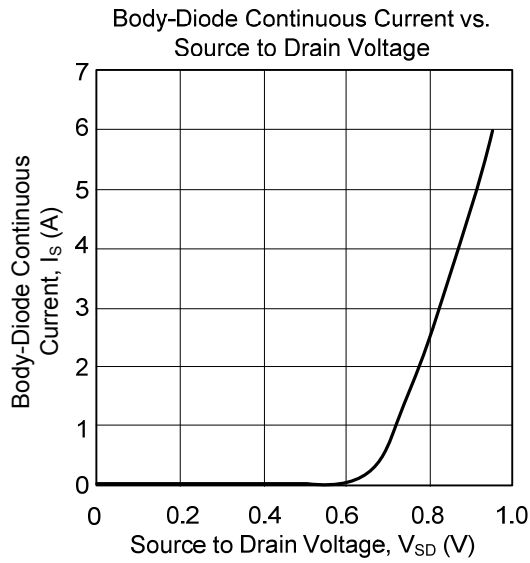

UTC assumes no responsibility for equipment failures that result from using products at values that exceed, even momentarily, rated values (such as maximum ratings, operating condition ranges, or other parameters) listed in products specifications of any and all UTC products described or contained herein. UTC products are not designed for use in life support appliances, devices or systems where malfunction of these products can be reasonably expected to result in personal injury. Reproduction in whole or in part is prohibited without the prior written consent of the copyright owner. The information presented in this document does not form part of any quotation or contract, is believed to be accurate and reliable and may be changed without notice.