



1N50K-TA

Power MOSFET

1.3A, 500V N-CHANNEL POWER MOSFET

DESCRIPTION

The UTC **1N50K-TA** is a N-channel mode power MOSFET using UTC's advanced technology to provide customers with planar stripe and DMOS technology. This technology allows a minimum on-state resistance and superior switching performance. It also can withstand high energy pulse in the avalanche and commutation mode.

The UTC **1N50K-TA** is generally applied in high efficiency switch mode power supplies, active power factor correction and electronic lamp ballasts based on half bridge topology.

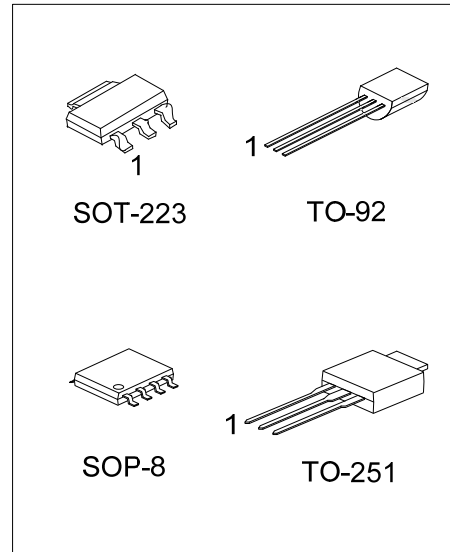

FEATURES

- * $R_{DS(ON)} \leq 6.0\Omega$ @ $V_{GS}=10V, I_D=0.65A$
- * High Switching Speed
- * 100% Avalanche Tested

SYMBOL

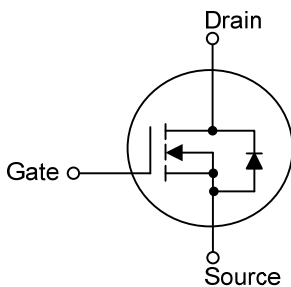

ORDERING INFORMATION

Ordering Number		Package	Pin Assignment								Packing	
Lead Free	Halogen Free		1	2	3	4	5	6	7	8		
1N50KL-AA3-R	1N50KG-AA3-R	SOT-223	G	D	S	-	-	-	-	-	-	Tape Reel
1N50KL-TM3-T	1N50KG-TM3-T	TO-251	G	D	S	-	-	-	-	-	-	Tube
1N50KL-T92-B	1N50KG-T92-B	TO-92	G	D	S	-	-	-	-	-	-	Tape Box
1N50KL-T92-K	1N50KG-T92-K	TO-92	G	D	S	-	-	-	-	-	-	Bulk
1N50KL-S08-R	1N50KG-S08-R	SOP-8	S	S	S	G	D	D	D	D	D	Tape Reel

Note: Pin Assignment: G: Gate D: Drain S: Source

<p>1N50KG-AA3-R</p> <ul style="list-style-type: none"> (1)Packing Type (2)Package Type (3)Green Package 	<ul style="list-style-type: none"> (1) R: Tape Reel, T: Tube, B: Tape Box, K: Bulk (2) AA3: SOT-223, TM3: TO-251, T92: TO-92 K08-5060: DFN5060-8 (3) G: Halogen Free and Lead Free, L: Lead Free
--	---

MARKING

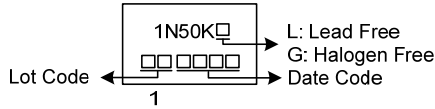
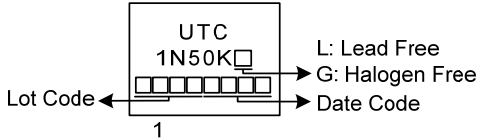
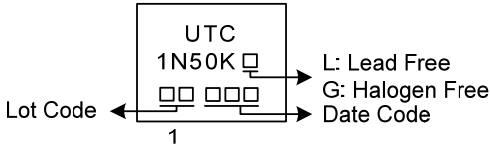
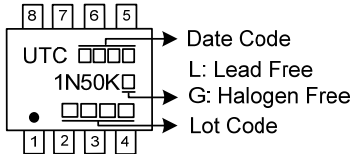
PACKAGE	MARKING
SOT-223	 <p>Diagram showing marking on a SOT-223 package. The marking includes '1N50K' and '1'. Arrows point to 'L: Lead Free', 'G: Halogen Free', and 'Date Code'.</p>
TO-251	 <p>Diagram showing marking on a TO-251 package. The marking includes 'UTC', '1N50K', and '1'. Arrows point to 'L: Lead Free', 'G: Halogen Free', and 'Date Code'.</p>
TO-92	 <p>Diagram showing marking on a TO-92 package. The marking includes 'UTC', '1N50K', and '1'. Arrows point to 'L: Lead Free', 'G: Halogen Free', and 'Date Code'.</p>
SOP-8	 <p>Diagram showing marking on an SOP-8 package. The marking includes 'UTC', '1N50K', and '1'. Arrows point to 'Date Code', 'L: Lead Free', 'G: Halogen Free', and 'Lot Code'.</p>

■ ABSOLUTE MAXIMUM RATINGS ($T_c=25^\circ\text{C}$, unless otherwise specified)

PARAMETER		SYMBOL	RATINGS	UNIT
Drain-Source Voltage		V_{DSS}	500	V
Gate-Source Voltage		V_{GSS}	± 30	V
Drain Current	Continuous ($T_c=25^\circ\text{C}$)	I_D	1.3 (Note 2)	A
	Pulsed (Note 3)	I_{DM}	5 (Note 2)	A
Avalanche Current (Note 3)		I_{AR}	1.3	A
Avalanche Energy	Single Pulsed (Note 4)	E_{AS}	35	mJ
	Repetitive (Note 5)	E_{AR}	2.6	mJ
Power Dissipation	SOT-223	P_D	7.8	W
	TO-251		25	W
	TO-92		1.56	W
	SOP-8		4	W
Junction Temperature		T_J	+150	$^\circ\text{C}$
Storage Temperature		T_{STG}	-55 ~ +150	$^\circ\text{C}$

Notes: 1. Absolute maximum ratings are those values beyond which the device could be permanently damaged.

Absolute maximum ratings are stress ratings only and functional device operation is not implied.

2. Drain current limited by maximum junction temperature.

3. Repetitive Rating: Pulse width limited by maximum junction temperature.

4. $L = 41\text{mH}$, $I_{AS} = 1.3\text{A}$, $V_{DD} = 50\text{V}$, $R_G = 27\Omega$, Starting $T_J = 25^\circ\text{C}$

5. $I_{SD} \leq 1.5\text{A}$, $di/dt \leq 200\text{A}/\mu\text{s}$, $V_{DD} \leq BV_{DSS}$, Starting $T_J = 25^\circ\text{C}$

■ THERMAL RESISTANCES CHARACTERISTICS

PARAMETER		SYMBOL	RATINGS	UNIT
Junction to Ambient	SOT-223	θ_{JA}	150	$^\circ\text{C}/\text{W}$
	TO-251		110	$^\circ\text{C}/\text{W}$
	TO-92		180	$^\circ\text{C}/\text{W}$
	SOP-8		75 (Note)	$^\circ\text{C}/\text{W}$
Junction to Case	SOT-223	θ_{JC}	16	$^\circ\text{C}/\text{W}$
	TO-251		5	$^\circ\text{C}/\text{W}$
	TO-92		80	$^\circ\text{C}/\text{W}$
	SOP-8		31.25 (Note)	$^\circ\text{C}/\text{W}$

Note: Device mounted on FR-4 substrate PC board, 2oz copper, with 1inch square copper plate.

■ ELECTRICAL CHARACTERISTICS ($T_c=25^\circ\text{C}$, unless otherwise specified)

PARAMETER	SYMBOL	TEST CONDITIONS	MIN	TYP	MAX	UNIT
OFF CHARACTERISTICS						
Drain-Source Breakdown Voltage	BV_{DSS}	$I_D=250\mu\text{A}$, $V_{GS}=0\text{V}$	500			V
Drain-Source Leakage Current	I_{DSS}	$V_{DS}=500\text{V}$, $V_{GS}=0\text{V}$			1	μA
Gate- Source Leakage Current	Forward	I_{GSS}			+100	nA
	Reverse				-100	nA
ON CHARACTERISTICS						
Gate Threshold Voltage	$V_{GS(TH)}$	$V_{DS}=V_{GS}$, $I_D=250\mu\text{A}$	3.0		5.0	V
Static Drain-Source On-State Resistance	$R_{DS(ON)}$	$V_{GS}=10\text{V}$, $I_D=0.65\text{A}$		5.0	6.0	Ω
DYNAMIC PARAMETERS						
Input Capacitance	C_{ISS}	$V_{GS}=0\text{V}$, $V_{DS}=25\text{V}$, $f=1.0\text{MHz}$		180		pF
Output Capacitance	C_{OSS}			30		pF
Reverse Transfer Capacitance	C_{RSS}			12.5		pF
SWITCHING PARAMETERS						
Total Gate Charge	Q_G	$V_{GS}=10\text{V}$, $V_{DS}=50\text{V}$, $I_D=1.3\text{A}$ (Note 1, 2)		11	15	nC
Gate to Source Charge	Q_{GS}			2.5		nC
Gate to Drain Charge	Q_{GD}			1		nC
Turn-ON Delay Time	$t_{D(ON)}$	$V_{DD}=30\text{V}$, $I_D=0.5\text{A}$, $R_G=25\Omega$ (Note 1, 2)		37.5		ns
Rise Time	t_R			20		ns
Turn-OFF Delay Time	$t_{D(OFF)}$			53		ns
Fall-Time	t_F			12		ns
SOURCE- DRAIN DIODE RATINGS AND CHARACTERISTICS						
Maximum Body-Diode Continuous Current	I_S				1.3	A
Maximum Body-Diode Pulsed Current	I_{SM}				5.2	A
Drain-Source Diode Forward Voltage	V_{SD}	$I_S=1.3\text{A}$, $V_{GS}=0\text{V}$			1.2	V
Body Diode Reverse Recovery Time (Note 2)	t_{rr}	$I_S=-1\text{A}$, $V_{GS}=0\text{V}$, $dI/dt=100\text{A}/\mu\text{s}$		194		ns
Body Diode Reverse Recovery Charge	Q_{rr}			170		nC

Notes: 1. Pulse Test: Pulse width $\leq 300\mu\text{s}$, Duty cycle $\leq 2\%$.

2. Essentially independent of operating temperature.

TEST CIRCUITS AND WAVEFORMS

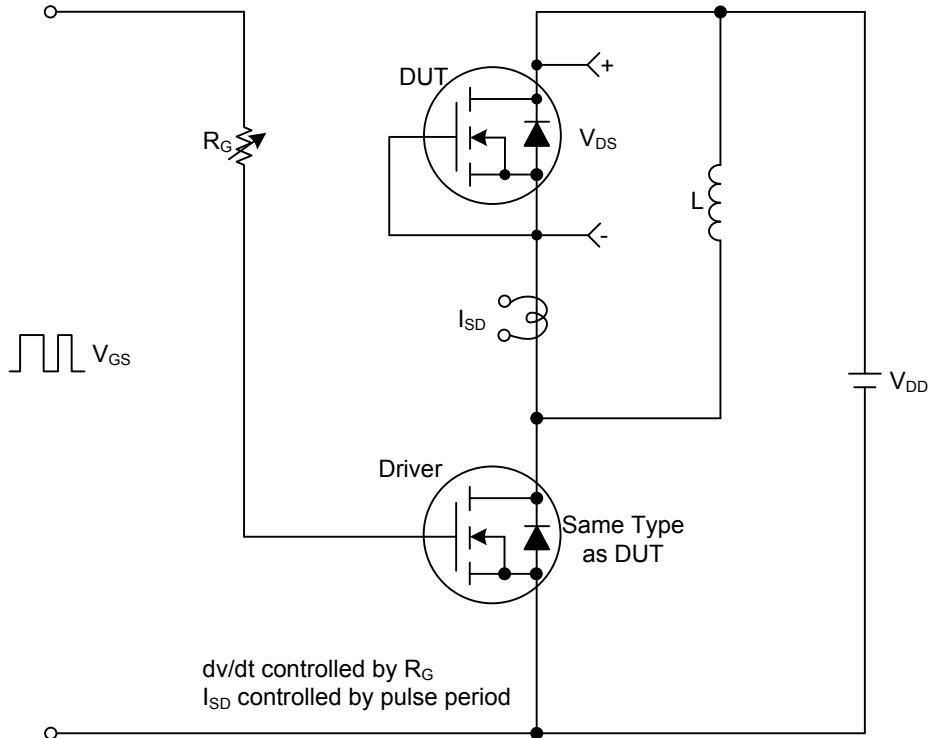

Peak Diode Recovery dv/dt Test Circuit & Waveforms

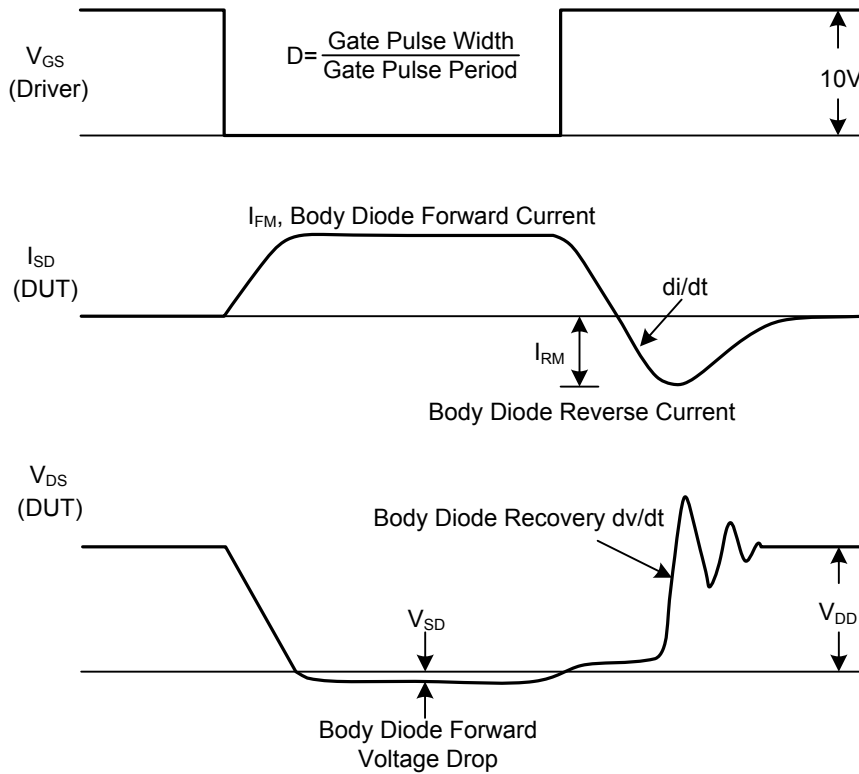

TEST CIRCUITS AND WAVEFORMS

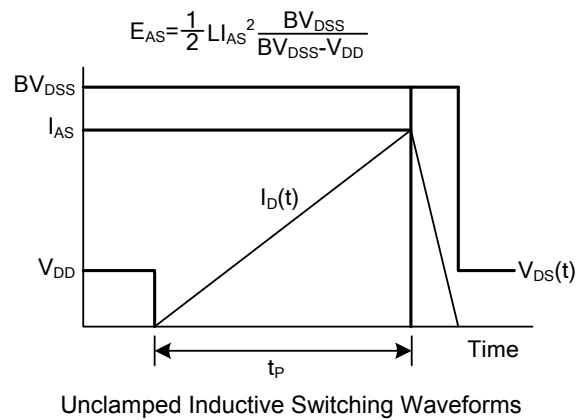
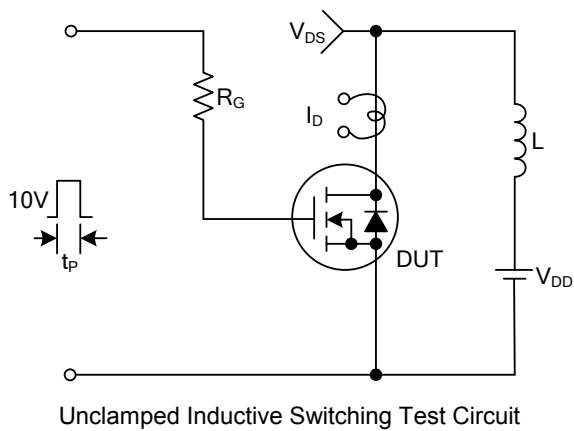
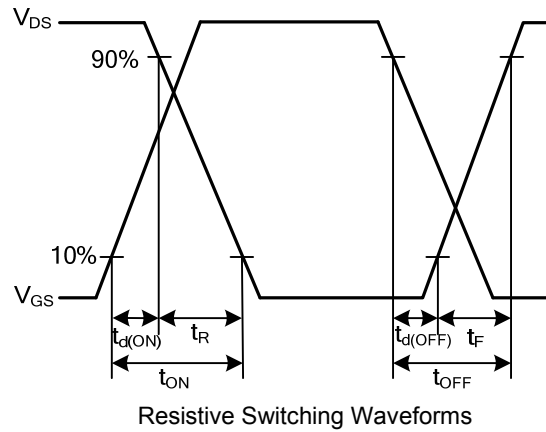
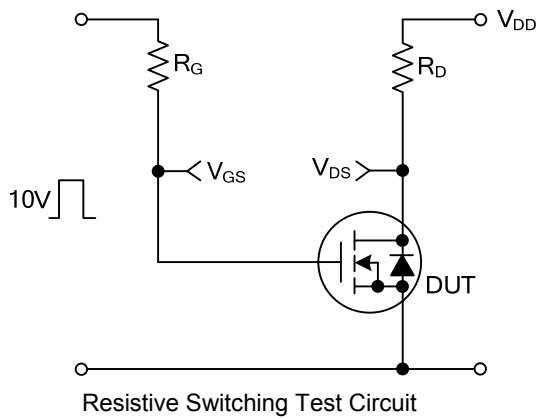
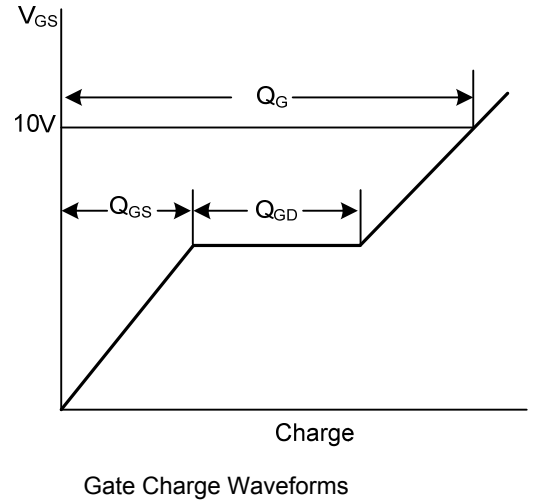
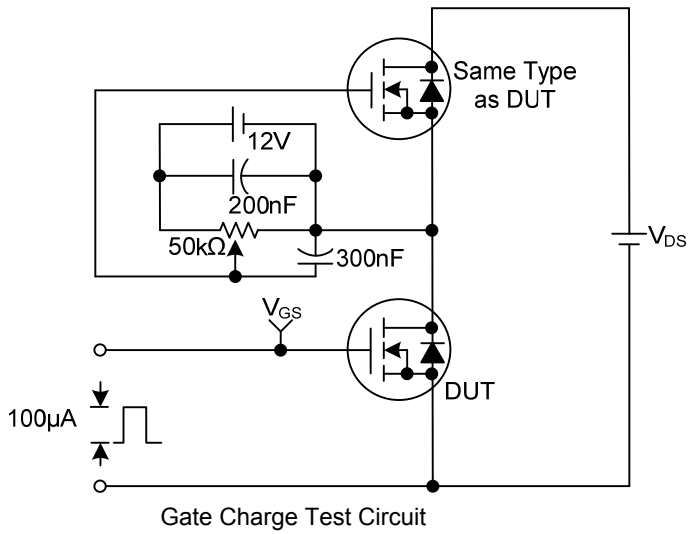

TYPICAL CHARACTERISTICS

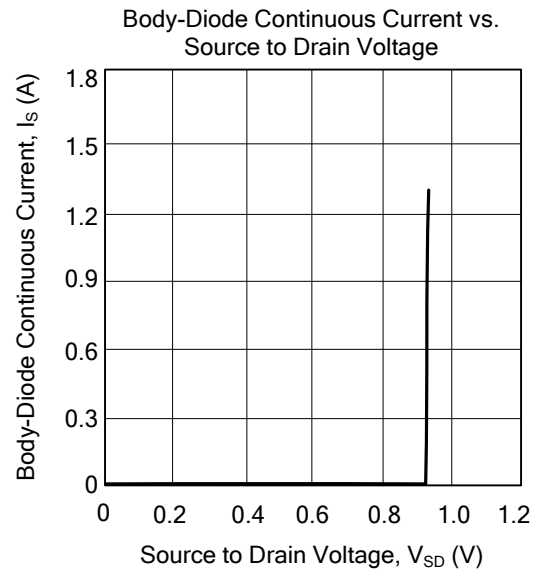
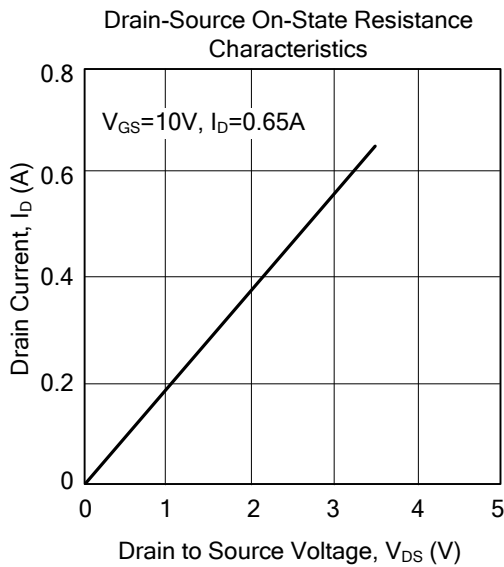
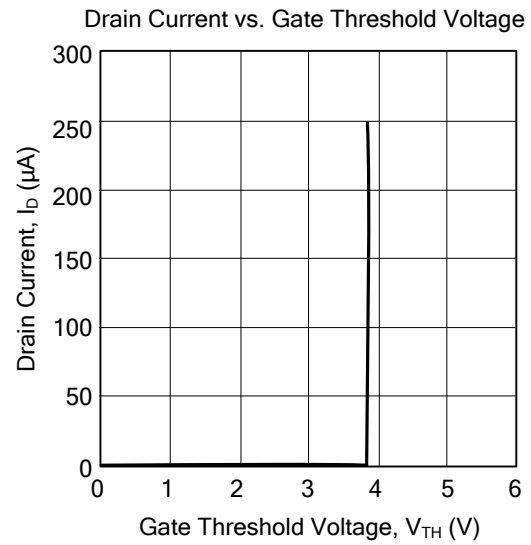
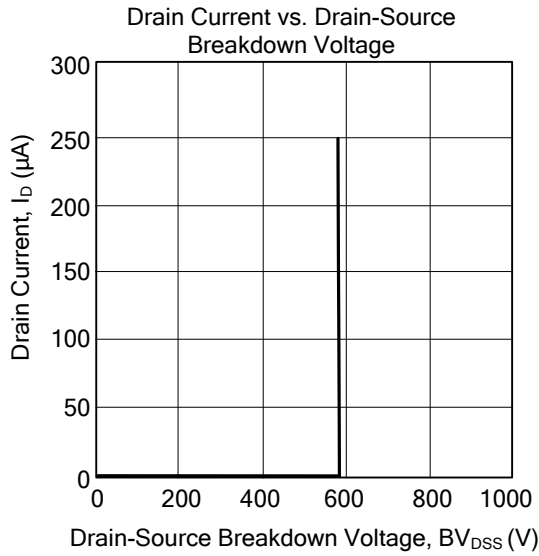

UTC assumes no responsibility for equipment failures that result from using products at values that exceed, even momentarily, rated values (such as maximum ratings, operating condition ranges, or other parameters) listed in products specifications of any and all UTC products described or contained herein. UTC products are not designed for use in life support appliances, devices or systems where malfunction of these products can be reasonably expected to result in personal injury. Reproduction in whole or in part is prohibited without the prior written consent of the copyright owner. UTC reserves the right to make changes to information published in this document, including without limitation specifications and product descriptions, at any time and without notice. This document supersedes and replaces all information supplied prior to the publication hereof.