



# 4N70K-TA

*Power MOSFET*

## 4.0A, 700V N-CHANNEL POWER MOSFET

■ DESCRIPTION

The UTC **4N70K-TA** is a high voltage power MOSFET and is designed to have better characteristics, such as fast switching time, low gate charge, low on-state resistance and high rugged avalanche. This high speed switching power MOSFET is usually used in power supplies, PWM motor controls, high efficient DC to DC converters and bridge circuits.

■ FEATURES

- \*  $R_{DS(ON)} < 3.5\Omega @ V_{GS} = 10V, I_D = 2A$
- \* Fast Switching Capability
- \* Avalanche Energy Specified
- \* Improved dv/dt Capability, High Ruggedness

■ SYMBOL

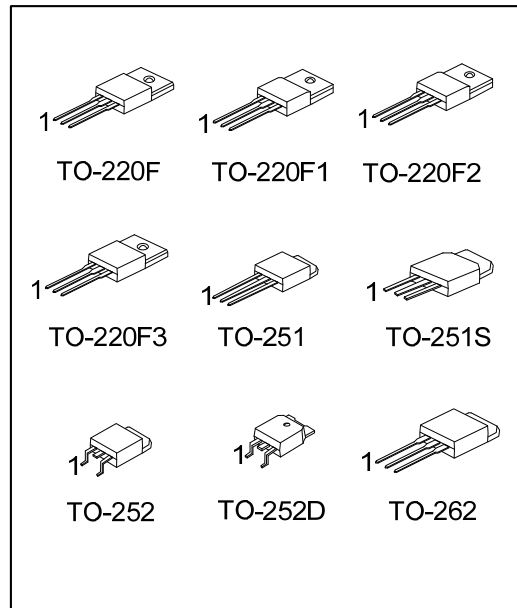
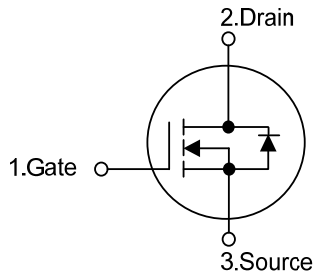

■ ORDERING INFORMATION

Ordering Number		Package	Pin Assignment			Packing
Lead Free	Halogen Free		1	2	3	
4N70KL-TF3-T	4N70KG-TF3-T	TO-220F	G	D	S	Tube
4N70KL-TF1-T	4N70KG-TF1-T	TO-220F1	G	D	S	Tube
4N70KL-TF2-T	4N70KG-TF2-T	TO-220F2	G	D	S	Tube
4N70KL-TF3T-T	4N70KG-TF3T-T	TO-220F3	G	D	S	Tube
4N70KL-TM3-T	4N70KG-TM3-T	TO-251	G	D	S	Tube
4N70KL-TMS-T	4N70KG-TMS-T	TO-251S	G	D	S	Tube
4N70KL-TN3-R	4N70KG-TN3-R	TO-252	G	D	S	Tape Reel
4N70KL-TND-R	4N70KG-TND-R	TO-252D	G	D	S	Tape Reel
4N70KL-T2Q-T	4N70KG-T2Q-T	TO-262	G	D	S	Tube

Note: Pin Assignment: G: Gate D: Drain S: Source

<p>4N70KL-TF3-T</p> <p>(1)Packing Type</p> <p>(2)Package Type</p> <p>(3)Green Package</p>	<p>(1) T: Tube, R: Tape Reel</p> <p>(2) TF3: TO-220F, TF1: TO-220F1, TF2: TO-220F2 TF3T: TO-220F3, TM3: TO-251, TMS: TO-251S TN3: TO-252, TND: TO-252D, T2Q: TO-262</p> <p>(3) L: Lead Free, G: Halogen Free and Lead Free</p>
---	--

■ MARKING

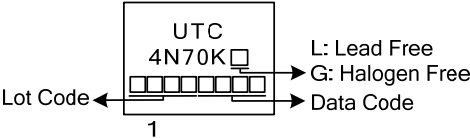

■ ABSOLUTE MAXIMUM RATINGS ( $T_A = 25^\circ\text{C}$ , unless otherwise specified)

PARAMETER		SYMBOL	RATINGS	UNIT
Drain-Source Voltage		$V_{DSS}$	700	V
Gate-Source Voltage		$V_{GSS}$	$\pm 30$	V
Avalanche Current (Note 2)		$I_{AR}$	4.0	A
Drain Current	Continuous	$I_D$	4.0	A
	Pulsed (Note 2)	$I_{DM}$	17.6	A
Avalanche Energy	Single Pulsed (Note 3)	$E_{AS}$	216	mJ
	Repetitive (Note 2)	$E_{AR}$	10.6	mJ
Power Dissipation	TO-220F/TO-220F1/ TO-220F2/TO-220F3	$P_D$	36	W
	TO-251/TO-251S TO-252/TO-252D		49	W
	TO-262		106	W
Peak Diode Recovery dv/dt (Note 4)		dv/dt	4.5	V/ns
Junction Temperature		$T_J$	+150	$^\circ\text{C}$
Operating Temperature		$T_{OPR}$	-55 ~ +150	$^\circ\text{C}$
Storage Temperature		$T_{STG}$	-55 ~ +150	$^\circ\text{C}$

Notes: 1. Absolute maximum ratings are those values beyond which the device could be permanently damaged.

Absolute maximum ratings are stress ratings only and functional device operation is not implied.

2. Repetitive Rating : Pulse width limited by maximum junction temperature

3.  $L = 27\text{mH}$ ,  $I_{AS} = 4\text{ A}$ ,  $V_{DD} = 50\text{V}$ ,  $R_G = 25\ \Omega$ , Starting  $T_J = 25^\circ\text{C}$

4.  $I_{SD} \leq 4.0\text{A}$ ,  $di/dt \leq 200\text{A}/\mu\text{s}$ ,  $V_{DD} \leq BV_{DSS}$ , Starting  $T_J = 25^\circ\text{C}$

■ THERMAL DATA

PARAMETER		SYMBOL	RATINGS	UNIT
Junction to Ambient	TO-220F/TO-220F1/ TO-220F2/TO-220F3 TO-262	$\theta_{JA}$	62.5	$^\circ\text{C}/\text{W}$
	TO-251/TO-251S TO-252/TO-252D		110	$^\circ\text{C}/\text{W}$
Junction to Case	TO-220F/TO-220F1 TO-220F3	$\theta_{JC}$	3.47	$^\circ\text{C}/\text{W}$
	TO-220F2		3.28	$^\circ\text{C}/\text{W}$
	TO-251/TO-251S TO-252/TO-252D		2.55	$^\circ\text{C}/\text{W}$
	TO-262		1.18	$^\circ\text{C}/\text{W}$

■ ELECTRICAL CHARACTERISTICS (T<sub>A</sub>=25°C, unless otherwise specified)

PARAMETER	SYMBOL	TEST CONDITIONS	MIN	TYP	MAX	UNIT
<b>OFF CHARACTERISTICS</b>						
Drain-Source Breakdown Voltage	BV <sub>DSS</sub>	V <sub>GS</sub> = 0 V, I <sub>D</sub> = 250 μA	700			V
Drain-Source Leakage Current	I <sub>DSS</sub>	V <sub>DS</sub> = 700 V, V <sub>GS</sub> = 0 V			10	μA
Gate-Source Leakage Current	Forward	I <sub>GSS</sub>			100	nA
	Reverse				-100	
Breakdown Voltage Temperature Coefficient	ΔBV <sub>DSS</sub> /ΔT <sub>J</sub>	I <sub>D</sub> = 250μA, Referenced to 25°C		0.6		V/°C
<b>ON CHARACTERISTICS</b>						
Gate Threshold Voltage	V <sub>GS(TH)</sub>	V <sub>DS</sub> = V <sub>GS</sub> , I <sub>D</sub> = 250 μA	2.0		4.0	V
Static Drain-Source On-State Resistance	R <sub>DS(ON)</sub>	V <sub>GS</sub> = 10 V, I <sub>D</sub> = 2 A			3.5	Ω
<b>DYNAMIC CHARACTERISTICS</b>						
Input Capacitance	C <sub>ISS</sub>	V <sub>DS</sub> = 25 V, V <sub>GS</sub> = 0 V, f = 1MHz		660	760	pF
Output Capacitance	C <sub>OSS</sub>		48	90	pF	
Reverse Transfer Capacitance	C <sub>RSS</sub>		5	11	pF	
<b>SWITCHING CHARACTERISTICS</b>						
Turn-On Delay Time	t <sub>D(ON)</sub>	V <sub>DD</sub> = 30V, I <sub>D</sub> = 0.5A, R <sub>G</sub> = 25Ω (Note 1, 2)		45		ns
Turn-On Rise Time	t <sub>R</sub>			32		ns
Turn-Off Delay Time	t <sub>D(OFF)</sub>			80		ns
Turn-Off Fall Time	t <sub>F</sub>			24		ns
Total Gate Charge	Q <sub>G</sub>	V <sub>DS</sub> = 50V, I <sub>D</sub> = 1.3A, V <sub>GS</sub> = 10 V (Note 1, 2)		37		nC
Gate-Source Charge	Q <sub>GS</sub>		4.8		nC	
Gate-Drain Charge	Q <sub>GD</sub>		6.0		nC	
<b>SOURCE- DRAIN DIODE RATINGS AND CHARACTERISTICS</b>						
Drain-Source Diode Forward Voltage	V <sub>SD</sub>	V <sub>GS</sub> = 0 V, I <sub>S</sub> = 4.0 A			1.4	V
Maximum Continuous Drain-Source Diode Forward Current	I <sub>S</sub>				4.0	A
Maximum Pulsed Drain-Source Diode Forward Current	I <sub>SM</sub>				17.6	A

Notes: 1. Pulse Test: Pulse width ≤ 300μs, Duty cycle ≤ 2%

2. Essentially independent of operating temperature

## TEST CIRCUITS AND WAVEFORMS

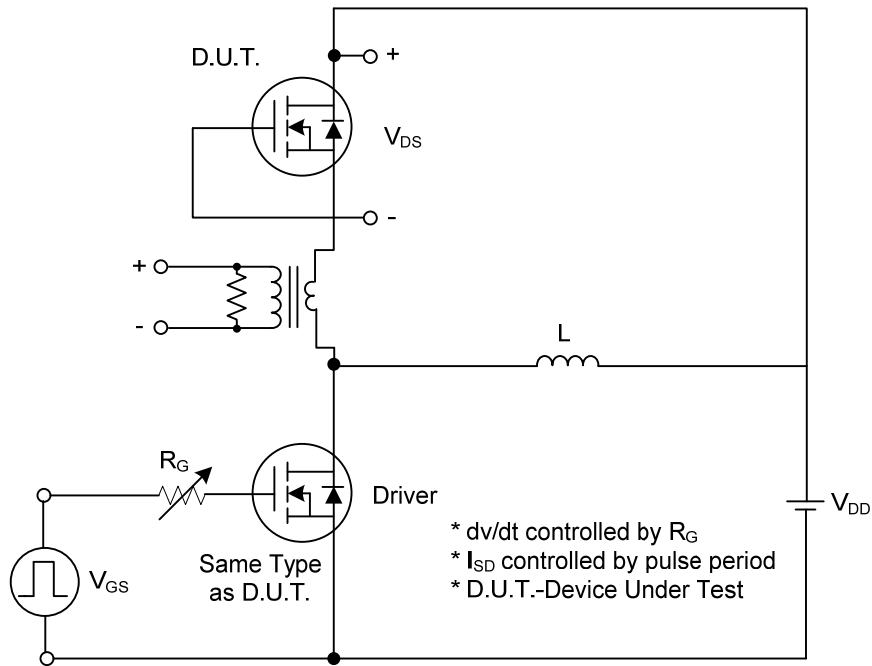

**Peak Diode Recovery dv/dt Test Circuit**

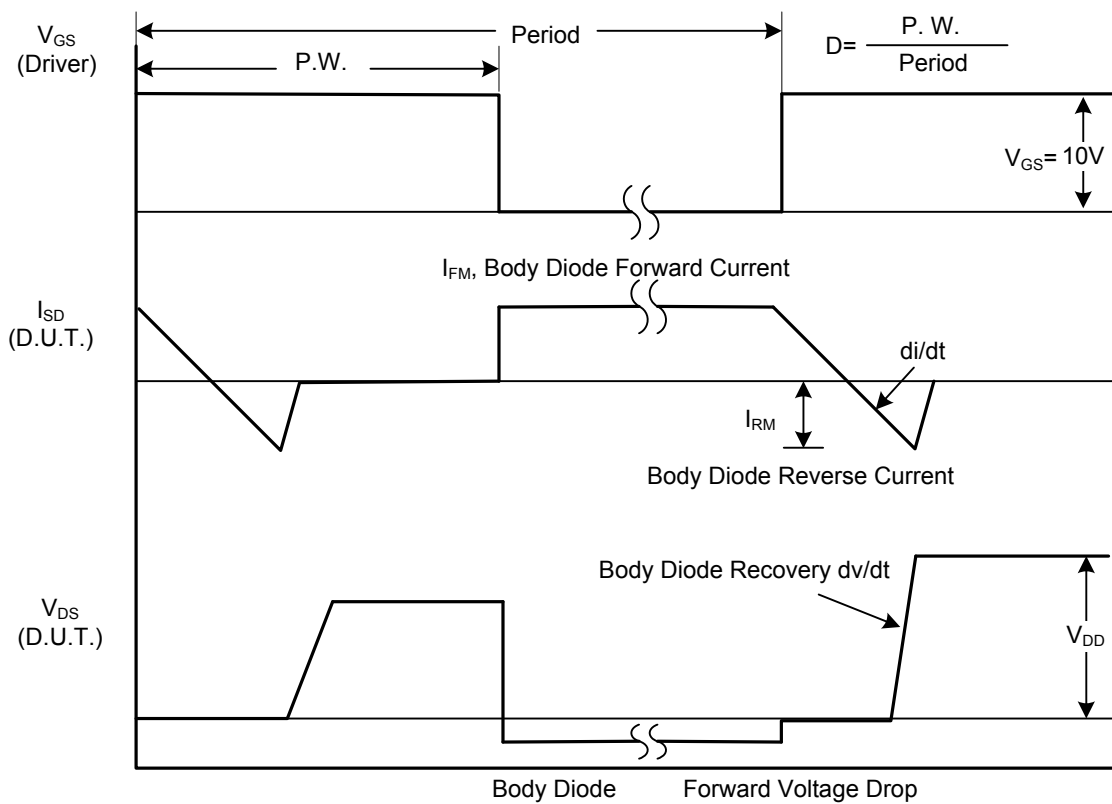

**Peak Diode Recovery dv/dt Waveforms**

## TEST CIRCUITS AND WAVEFORMS (Cont.)

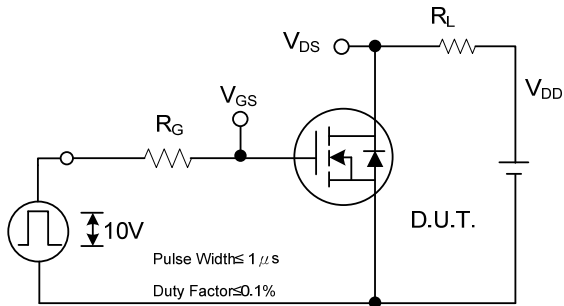

**Switching Test Circuit**

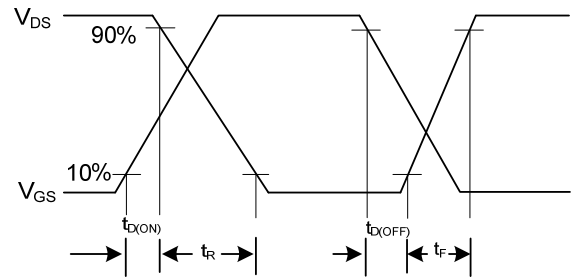

**Switching Waveforms**

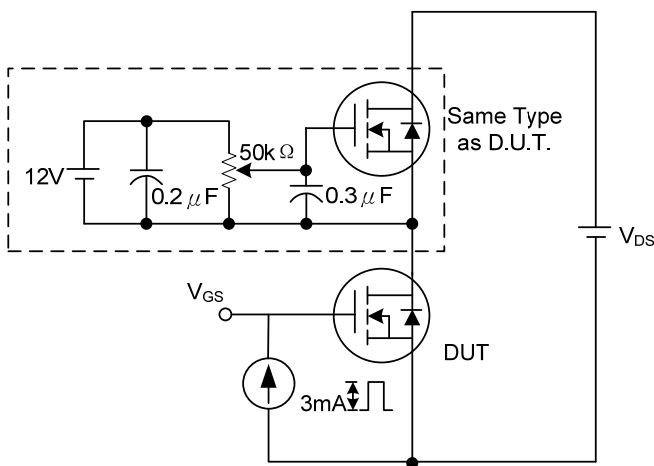

**Gate Charge Test Circuit**

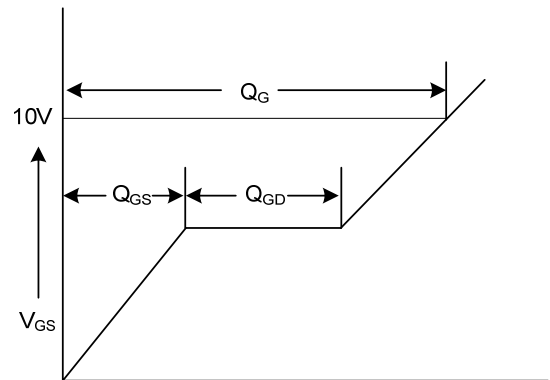

**Gate Charge Waveform**

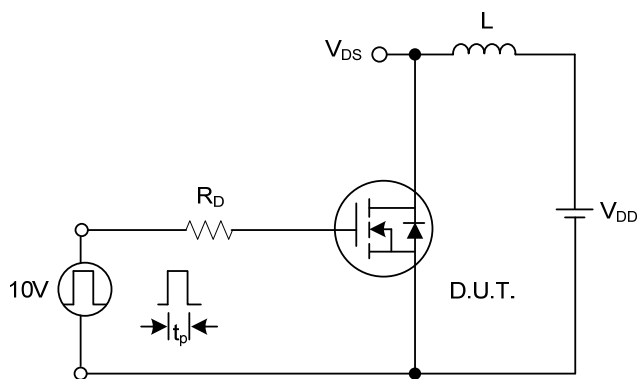

**Unclamped Inductive Switching Test Circuit**

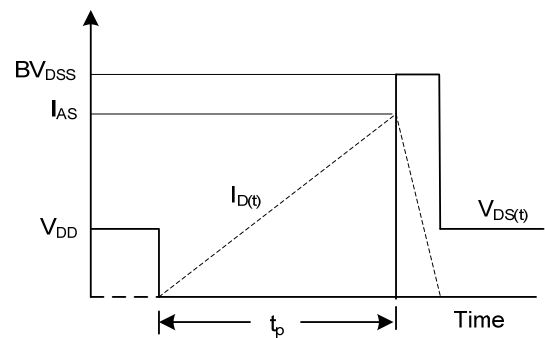

**Unclamped Inductive Switching Waveforms**

## TYPICAL CHARACTERISTICS

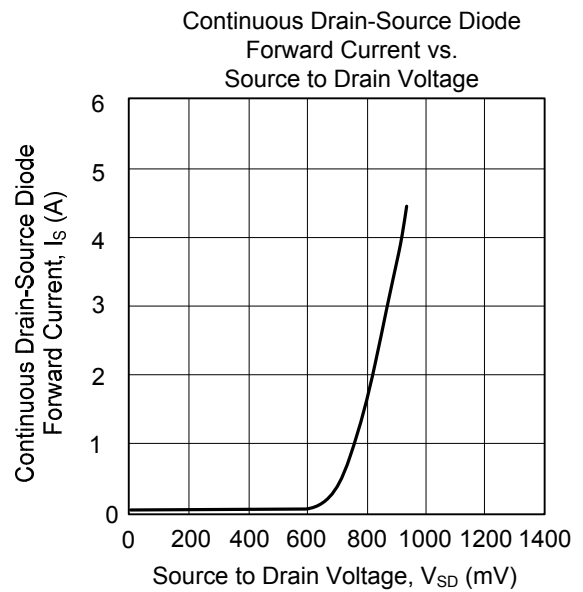
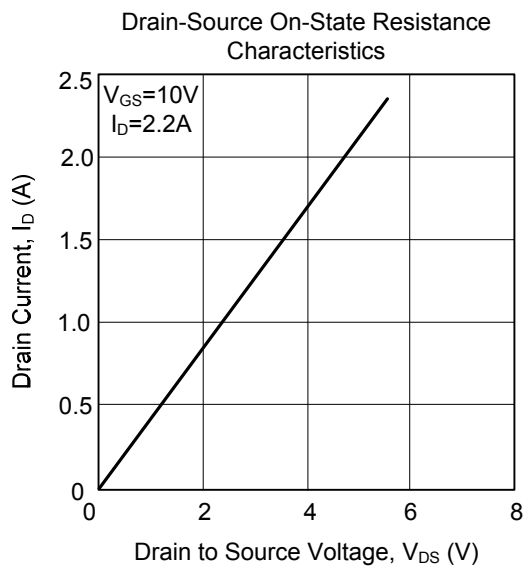
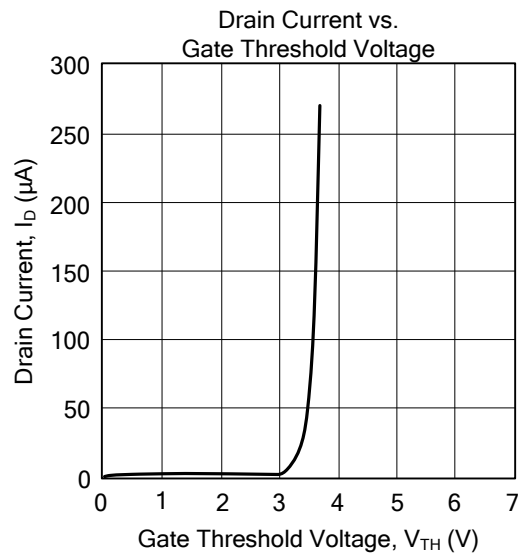
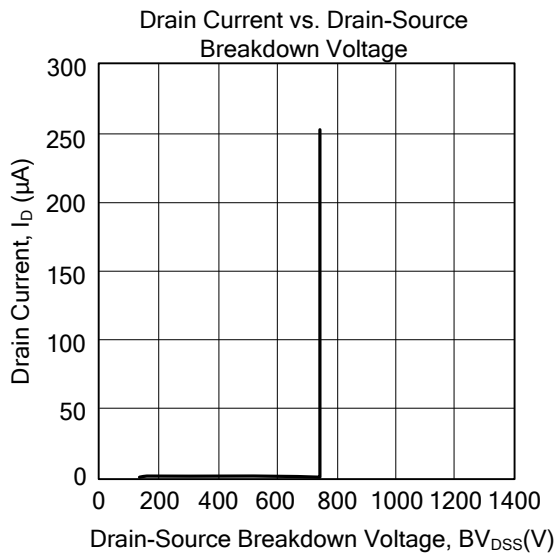

UTC assumes no responsibility for equipment failures that result from using products at values that exceed, even momentarily, rated values (such as maximum ratings, operating condition ranges, or other parameters) listed in products specifications of any and all UTC products described or contained herein. UTC products are not designed for use in life support appliances, devices or systems where malfunction of these products can be reasonably expected to result in personal injury. Reproduction in whole or in part is prohibited without the prior written consent of the copyright owner. The information presented in this document does not form part of any quotation or contract, is believed to be accurate and reliable and may be changed without notice.