



## MJE13001-Q

## NPN SILICON TRANSISTOR

### NPN SILICON POWER TRANSISTOR

#### FEATURES

- \* Collector-base voltage:  $V_{(BR)CBO}=600V$
- \* Collector current:  $I_C=0.2A$

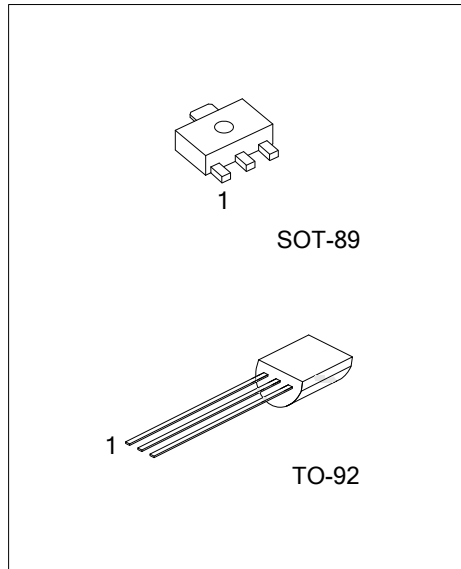

#### ORDERING INFORMATION

Ordering Number		Package	Pin Assignment			Packing
Lead Free	Halogen Free		1	2	3	
MJE13001L-Q-x-AB3-A-R	MJE13001G-Q-x-AB3-A-R	SOT-89	E	C	B	Tape Reel
MJE13001L-Q-x-AB3-F-R	MJE13001G-Q-x-AB3-F-R	SOT-89	B	C	E	Tape Reel
MJE13001L-Q-x-T92-F-B	MJE13001G-Q-x-T92-F-B	TO-92	B	C	E	Tape Box
MJE13001L-Q-x-T92-F-K	MJE13001G-Q-x-T92-F-K	TO-92	B	C	E	Bulk

Note: Pin assignment: B: Base C: Collector E: Emitter

<p>MJE13001G-Q-x-AB3-A-R</p>	<p>(1) R: Tape Reel, B: Tape Box, K: Bulk          (2) refer to Pin Assignment          (3) AB3: SOT-89, T92: TO-92          (4) x: refer to Classification of <math>h_{FE1}</math>          (5) G: Halogen Free and Lead Free, L: Lead Free</p>
------------------------------	--

#### MARKING

SOT-89	TO-92

### ■ ABSOLUTE MAXIMUM RATINGS

PARAMETER		SYMBOL	RATINGS	UNIT
Collector-Emitter Voltage		$V_{CEO}$	400	V
Collector-Base Voltage		$V_{CBO}$	600	V
Emitter Base Voltage		$V_{EBO}$	7	V
Collector Current		$I_C$	200	mA
Collector Power Dissipation	SOT-89	$P_C$	550	mW
	TO-92		750	
Junction Temperature		$T_J$	+150	°C
Storage Temperature		$T_{STG}$	-55 ~ +150	°C

Note: Absolute maximum ratings are those values beyond which the device could be permanently damaged.

Absolute maximum ratings are stress ratings only and functional device operation is not implied.

### ■ ELECTRICAL CHARACTERISTICS ( $T_A=25^\circ\text{C}$ , unless otherwise specified)

PARAMETER	SYMBOL	TEST CONDITIONS	MIN	TYP	MAX	UNIT
Collector-Base Breakdown Voltage	$BV_{CBO}$	$I_C=100\mu\text{A}, I_E=0$	600			V
Collector-Emitter Breakdown Voltage	$BV_{CEO}$	$I_C=1\text{mA}, I_B=0$	400			V
Emitter-Base Breakdown Voltage	$BV_{EBO}$	$I_E=100\mu\text{A}, I_C=0$	7			V
Base-Emitter Voltage	$V_{BE}$	$I_E=100\text{mA}$			1.1	V
Collector Cutoff Cut-Off Current	$I_{CBO}$	$V_{CB}=600\text{V}, I_E=0\text{A}$			100	$\mu\text{A}$
Collector Emitter Cut-Off Current	$I_{CEO}$	$V_{CE}=400\text{V}, I_B=0$			200	$\mu\text{A}$
Emitter Cutoff Cut-Off Current	$I_{EBO}$	$V_{EB}=7\text{V}, I_C=0\text{A}$			100	$\mu\text{A}$

#### ON CHARACTERISTICS

DC Current Gain	$h_{FE1}^*$	$V_{CE}=20\text{V}, I_C=20\text{mA}$	15		35	
	$h_{FE2}$	$V_{CE}=10\text{V}, I_C=0.25\text{mA}$	5			
Collector-Emitter Saturation Voltage	$V_{CE(SAT)}$	$I_C=50\text{mA}, I_B=10\text{mA}$			0.5	V
Base-Emitter Saturation Voltage	$V_{BE(SAT)}$	$I_C=50\text{mA}, I_B=10\text{mA}$			1.2	V

#### SMALL-SIGNAL CHARACTERISTICS

Current Gain Bandwidth Product	$f_T$	$I_C=20\text{mA}, V_{CE}=20\text{V}, f=1\text{MHz}$	8			MHz
--------------------------------	-------	---	---	--	--	-----

#### Resistive Load

Storage Time	$t_S$	$I_C=50\text{mA}, I_{B1}=-I_{B2}=5\text{mA}$ ,			1.5	$\mu\text{s}$
Fall Time	$t_F$	$V_{CC}=45\text{V}$			0.3	$\mu\text{s}$

### ■ CLASSIFICATION OF $h_{FE1}$

RANK	B	C	D	E
RANGE	15-20	20-25	25-30	30-35

### ■ TYPICAL CHARACTERISTICS

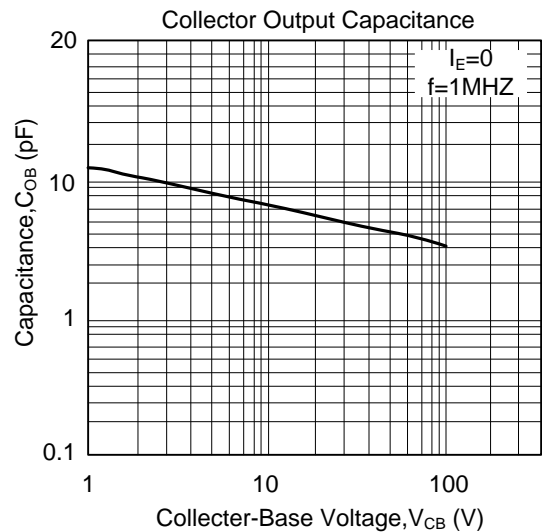
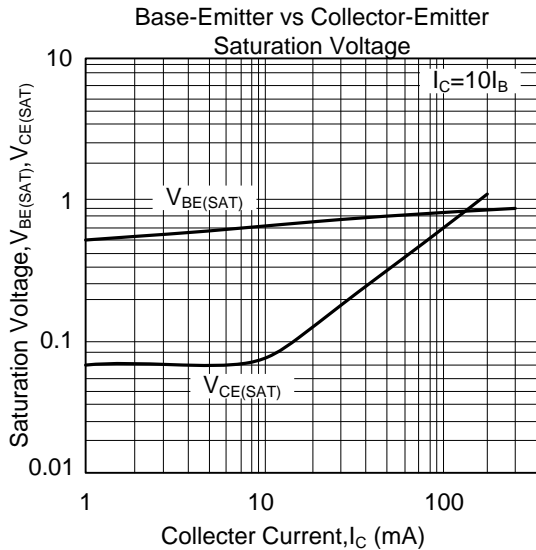
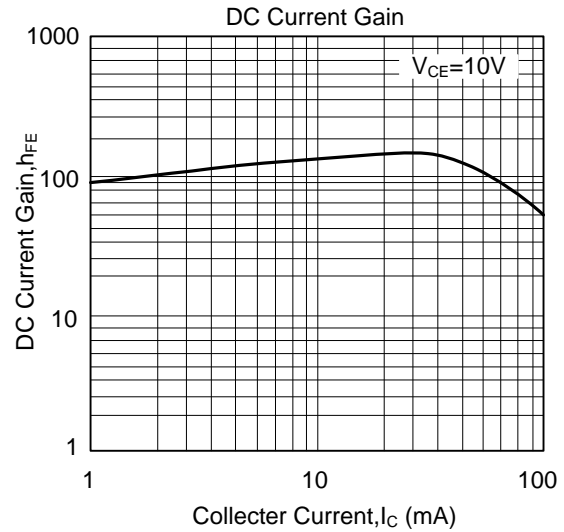
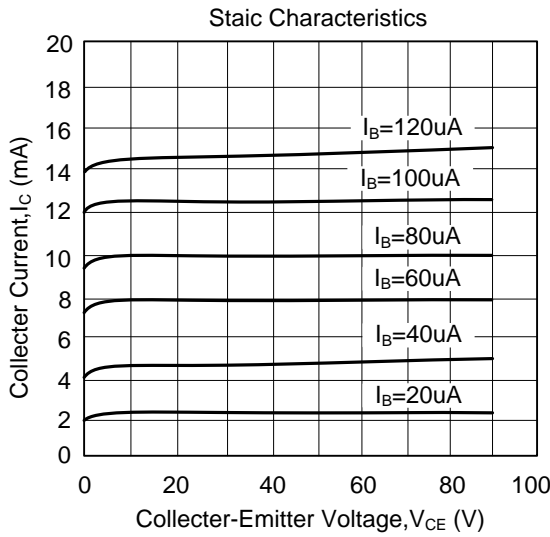

UTC assumes no responsibility for equipment failures that result from using products at values that exceed, even momentarily, rated values (such as maximum ratings, operating condition ranges, or other parameters) listed in products specifications of any and all UTC products described or contained herein. UTC products are not designed for use in life support appliances, devices or systems where malfunction of these products can be reasonably expected to result in personal injury. Reproduction in whole or in part is prohibited without the prior written consent of the copyright owner. UTC reserves the right to make changes to information published in this document, including without limitation specifications and product descriptions, at any time and without notice. This document supersedes and replaces all information supplied prior to the publication hereof.