



UF3808

Preliminary

POWER MOSFET

140A, 75V N-CHANNEL POWER MOSFET

DESCRIPTION

The UTC **UF3808** is an N-channel Power MOSFET, it uses UTC's advanced technology to provide the customers with high switching speed and a minimum on-state resistance.

The UTC **UF3808** is suitable for Automotive applications and Anti-lock Braking System (ABS), etc.

FEATURES

- * $R_{DS(ON)} < 8.0m\Omega @ V_{GS}=10V$
- * High Switching Speed
- * Dynamic dv/dt Rating

SYMBOL

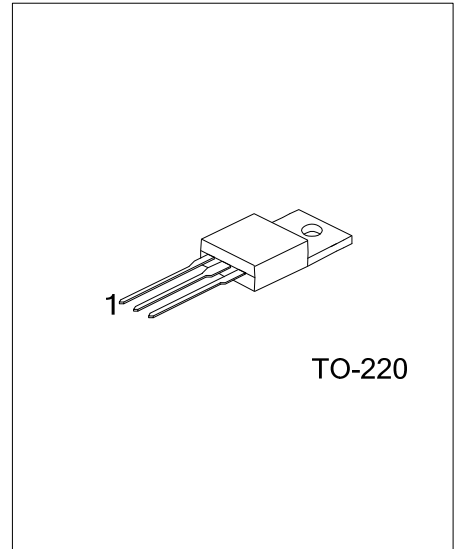
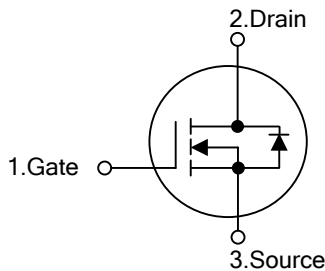

ORDERING INFORMATION

Ordering Number		Package	Pin Assignment			Packing
Lead Free	Halogen Free		1	2	3	
UF3808L-TA3-T	UF3808G-TA3-T	TO-220	G	D	S	Tube

Note: Pin Assignment: G: Gate D: Drain S: Source

<p>UF3808L-TA3-T</p> <p>(1)Packing Type</p> <p>(2)Package Type</p> <p>(3)Green Package</p>	<p>(1) T: Tube</p> <p>(2) TA3: TO-220</p> <p>(3) L: Lead Free, G: Halogen Free and Lead Free</p>
--	--

MARKING

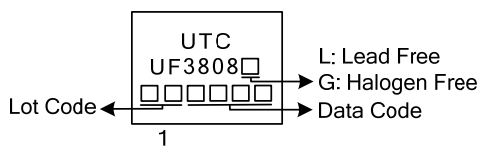

■ ABSOLUTE MAXIMUM RATING

PARAMETER		SYMBOL	RATINGS	UNIT	
Drain-Source Voltage		V_{DSS}	75	V	
Gate-Source Voltage		V_{GSS}	± 20	V	
Drain Current	Continuous (Note 6)	I_D	$V_{GS}=10V, T_C=25^\circ C$	140	A
			$V_{GS}=10V, T_C=100^\circ C$	97	A
	Pulsed (Note 5)	I_{DM}		550	A
Avalanche Current (Note 5)		I_{AR}	82	A	
Avalanche Energy Single Pulse (Note 3)		E_{AS}	430	mJ	
Peak Diode Recovery dv/dt (Note 4)		dv/dt	5.5	V/ns	
Power Dissipation ($T_C=25^\circ C$)		P_D	330	W	
Linear Derating Factor			2.2	W/ $^\circ C$	
Junction Temperature		T_J	-55~+175	$^\circ C$	
Storage Temperature Range		T_{STG}	-55~+175	$^\circ C$	

Notes: 1. Absolute maximum ratings are those values beyond which the device could be permanently damaged.

Absolute maximum ratings are stress ratings only and functional device operation is not implied.

2. Pulse width limited by safe operating area.

3. $L=0.13mH, I_{AS}=82A, V_{DD}=38V, R_G=25 \Omega$, Starting $T_J = 25^\circ C$

4. $I_{SD} \leq 82A, di/dt \leq 310A/\mu s, V_{DD} \leq BV_{DSS}$, Starting $T_J = 25^\circ C$

5. Repetitive rating; pulse width limited by max. junction temperature.

6. Calculated continuous current based on maximum allowable junction temperature. Package limitation current is 75A.

■ THERMAL DATA

PARAMETER	SYMBOL	RATINGS	UNIT
Junction to Ambient	θ_{JA}	62	$^\circ C/W$
Junction to Case	θ_{JC}	0.45	$^\circ C/W$

■ ELECTRICAL CHARACTERISTICS (T_J=25°C, unless otherwise specified)

PARAMETER	SYMBOL	TEST CONDITIONS	MIN	TYP	MAX	UNIT
OFF CHARACTERISTICS						
Drain-Source Breakdown Voltage	BV _{DSS}	V _{GS} =0V, I _D =250μA	75			V
Breakdown Voltage Temperature Coefficient	ΔBV _{DSS} /ΔT _J	Reference to 25°C, I _D =1mA		0.086		V/°C
Drain-Source Leakage Current	I _{DSS}	V _{DS} =75V, V _{GS} =0V			20	μA
		V _{DS} =60V, V _{GS} =0V, T _J =150°C			250	μA
Gate-Source Leakage Current	Forward	I _{GSS}				
	Reverse					
		V _{GS} =-20V, V _{DS} =0V			-200	nA
ON CHARACTERISTICS						
Static Drain-Source On-State Resistance (Note 1)	R _{DS(ON)}	V _{GS} =10V, I _D =82A			8.0	mΩ
Gate Threshold Voltage	V _{GS(TH)}	V _{DS} =10V, I _D =250μA	2.0		4.0	V
Forward Transconductance	g _{FS}	V _{DS} =25V, I _D =82A	100			S
DYNAMIC PARAMETERS						
Input Capacitance	C _{ISS}	V _{GS} =0V, V _{DS} =25V, f=1.0MHz		1510		pF
Output Capacitance	C _{OSS}			780		pF
Reverse Transfer Capacitance	C _{RSS}			350		pF
SWITCHING PARAMETERS						
Total Gate Charge	Q _G	V _{GS} =10V, V _{DS} =50V, I _D =1.3A I _G =100μA (Note 1)		138	160	nC
Gate to Source Charge	Q _{GS}			41		nC
Gate to Drain ("Miller") Charge	Q _{GD}			27		nC
Turn-ON Delay Time	t _{D(ON)}	V _{DD} =30V, I _D =1A, R _G =25Ω V _{GS} =10V (Note 1)		170		ns
Rise Time	t _R			440		ns
Turn-OFF Delay Time	t _{D(OFF)}			1000		ns
Fall Time	t _F			480		ns
SOURCE- DRAIN DIODE RATINGS AND CHARACTERISTICS						
Maximum Body Diode Continuous Source Current (Note 1)	I _S				140	A
Maximum Body-Diode Pulsed Current (Note 3)	I _{SM}				550	A
Drain-Source Diode Forward Voltage	V _{SD}	T _J =25°C, I _S =82A, V _{GS} =0V (Note 1)			1.3	V
Body Diode Reverse Recovery Time	t _{RR}	T _J =25°C, I _F =82A, dI/dt=100A/μs (Note 1)		93	140	ns
Body Diode Reverse Recovery Charge	Q _{RR}			340	510	nC

Notes: 1. Pulse width ≤ 400μs; duty cycle ≤ 2%.

2. C_{OSS} eff. is a fixed capacitance that gives the same charging time as C_{OSS} while V_{DS} is rising from 0 to 80% V_{DSS}.

3. Repetitive rating; pulse width limited by max. junction temperature.

■ TEST CIRCUITS AND WAVEFORMS

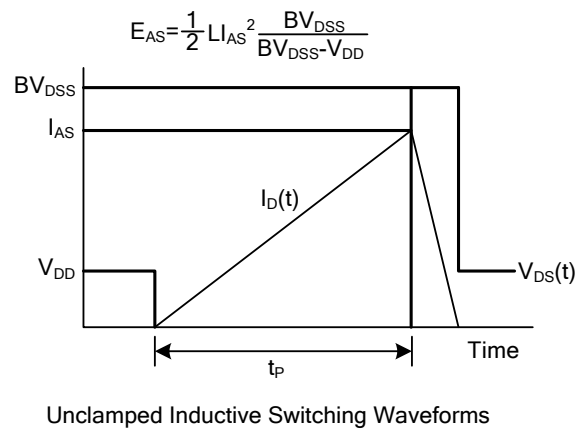
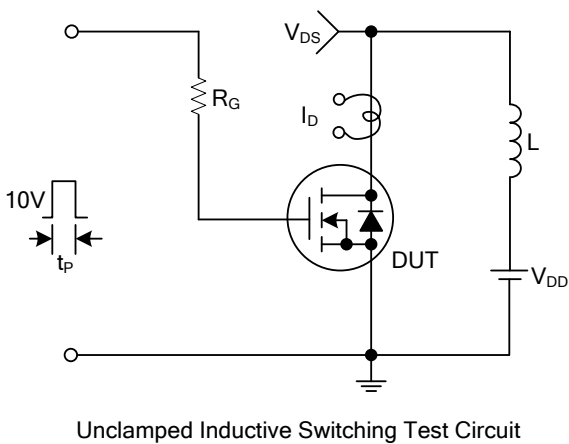
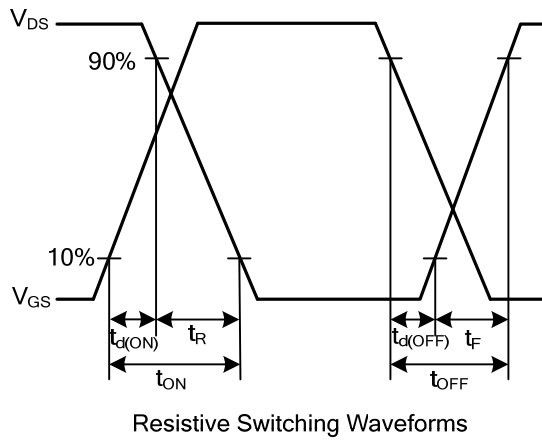
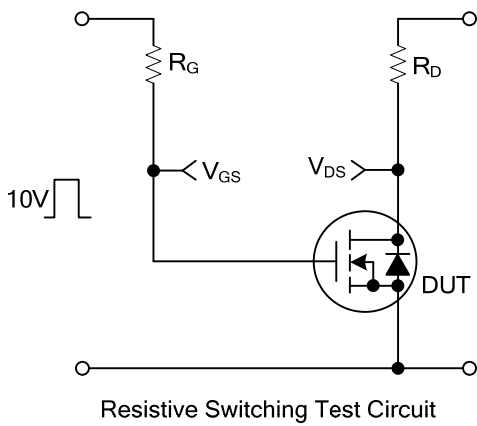
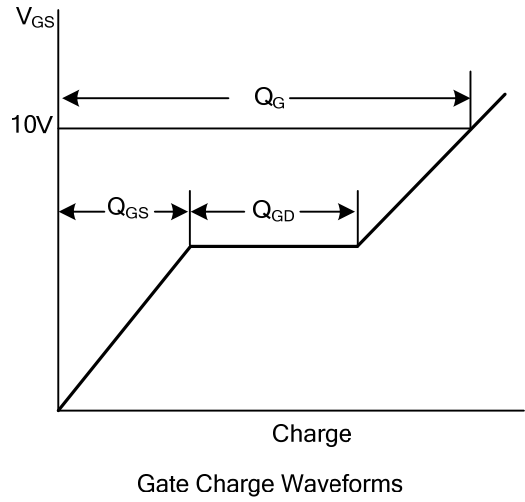
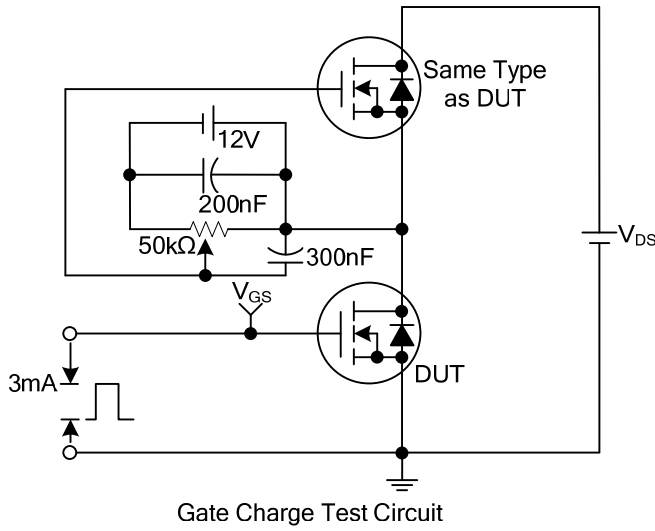

■ TEST CIRCUITS AND WAVEFORMS

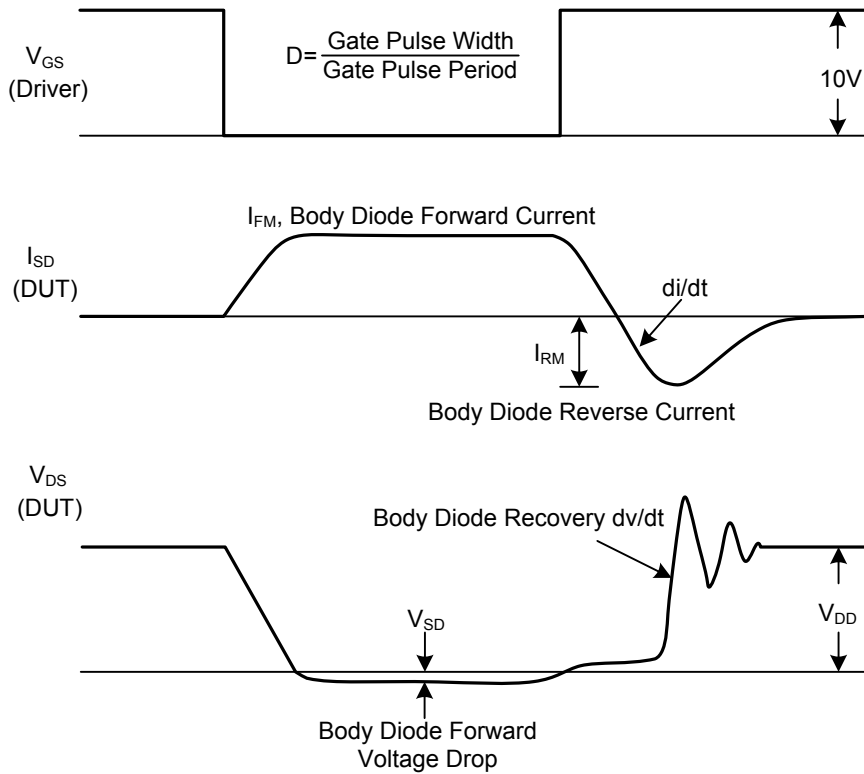
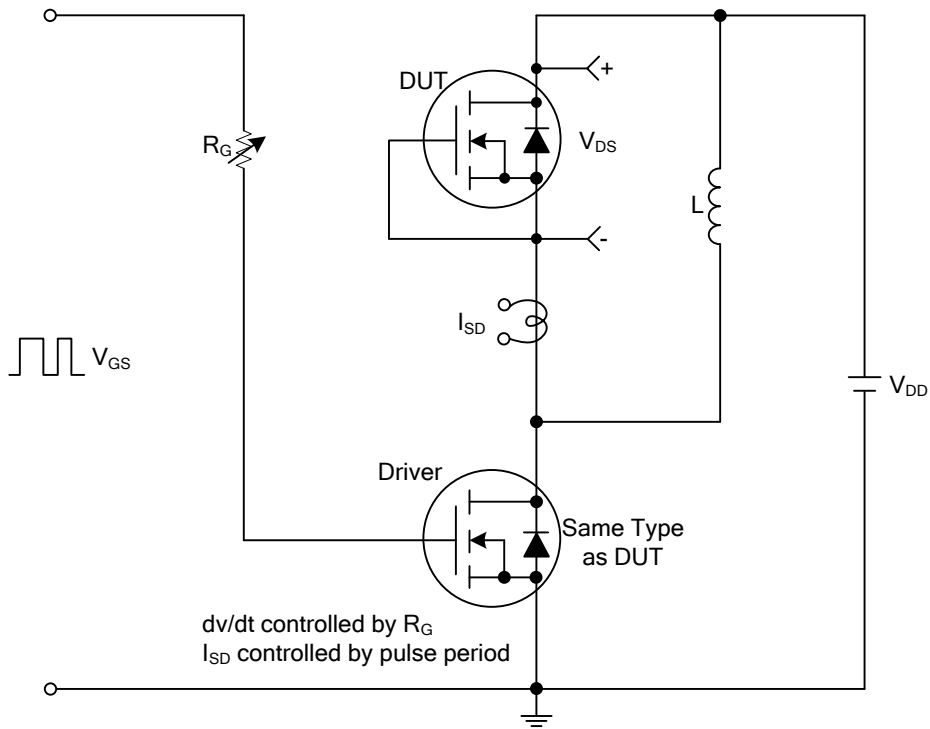

Peak Diode Recovery dv/dt Test Circuit and Waveforms

UTC assumes no responsibility for equipment failures that result from using products at values that exceed, even momentarily, rated values (such as maximum ratings, operating condition ranges, or other parameters) listed in products specifications of any and all UTC products described or contained herein. UTC products are not designed for use in life support appliances, devices or systems where malfunction of these products can be reasonably expected to result in personal injury. Reproduction in whole or in part is prohibited without the prior written consent of the copyright owner. The information presented in this document does not form part of any quotation or contract, is believed to be accurate and reliable and may be changed without notice.