



2N70K-MT

Power MOSFET

2A, 700V N-CHANNEL POWER MOSFET

■ DESCRIPTION

The UTC **2N70K-MT** is a high voltage MOSFET designed to have better characteristics, such as fast switching time, low gate charge, low on-state resistance and high rugged avalanche characteristics. This power MOSFET is usually used at high speed switching applications in power supplies, PWM motor controls, high efficient DC to DC converters and bridge circuits.

■ FEATURES

- * $R_{DS(ON)} < 5.5\Omega @ V_{GS} = 10V, I_D = 1.0 A$
- * Fast switching capability
- * Avalanche energy specified
- * Improved dv/dt capability, high ruggedness

■ SYMBOL

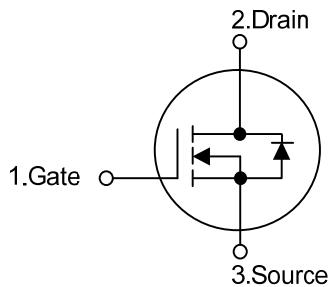

■ ORDERING INFORMATION

| Ordering Number | | Package | Pin Assignment | | | Packing |
|-----------------|---------------|----------|----------------|---|---|-----------|
| Lead Free | Halogen Free | | 1 | 2 | 3 | |
| 2N70KL-TF3-T | 2N70KG-TF3-T | TO-220F | G | D | S | Tube |
| 2N70KL-TF1-T | 2N70KG-TF1-T | TO-220F1 | G | D | S | Tube |
| 2N70KL-TF2-T | 2N70KG-TF2-T | TO-220F2 | G | D | S | Tube |
| 2N70KL-TF3T-T | 2N70KG-TF3T-T | TO-220F3 | G | D | S | Tube |
| 2N70KL-TM3-T | 2N70KG-TM3-T | TO-251 | G | D | S | Tube |
| 2N70KL-TMS-T | 2N70KG-TMS-T | TO-251S | G | D | S | Tube |
| 2N70KL-TN3-R | 2N70KG-TN3-R | TO-252 | G | D | S | Tape Reel |
| 2N70KL-TND-R | 2N70KG-TND-R | TO-252D | G | D | S | Tape Reel |

Note: Pin Assignment: G: Gate D: Drain S: Source

| | |
|---|---|
| <p>2N70KL-TF3-T</p> <p>(1)Packing Type</p> <p>(2)Package Type</p> <p>(3)Green Package</p> | <p>(1) T: Tube, R: Tape Reel</p> <p>(2) TF3: TO-220F, TF1: TO-220F1, TF1: TO-220F2 TF3T: TO-220F3, TM3: TO-251, TMS: TO-251S TN3: TO-252, TND: TO-252D</p> <p>(3) L: Lead Free, G: Halogen Free and Lead Free</p> |
|---|---|

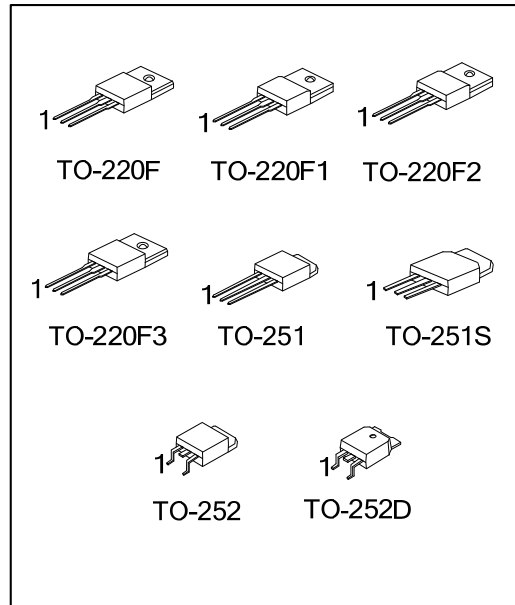

■ MARKING

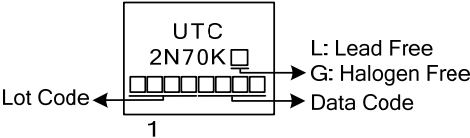

■ ABSOLUTE MAXIMUM RATINGS ($T_C = 25^\circ\text{C}$, unless otherwise specified)

| PARAMETER | | SYMBOL | RATINGS | UNIT |
|------------------------------------|----------------------------------|-----------|------------|------------------|
| Drain-Source Voltage | | V_{DSS} | 700 | V |
| Gate-Source Voltage | | V_{GSS} | ± 30 | V |
| Drain Current | Continuous | I_D | 2.0 | A |
| | Pulsed (Note 2) | I_{DM} | 8.0 | A |
| Avalanche Energy | Single Pulsed (Note 3) | E_{AS} | 100 | mJ |
| Peak Diode Recovery dv/dt (Note 4) | | dv/dt | 4.5 | V/ns |
| Power Dissipation | TO-220F/TO-220F1 TO-220F3 | P_D | 28 | W |
| | TO-220F2 | | 29 | W |
| | TO-251/TO-251S TO-252/TO-252D | | 30 | W |
| | | | | |
| Junction Temperature | | T_J | +150 | $^\circ\text{C}$ |
| Operating Temperature | | T_{OPR} | -55 ~ +150 | $^\circ\text{C}$ |
| Storage Temperature | | T_{STG} | -55 ~ +150 | $^\circ\text{C}$ |

Notes: 1. Absolute maximum ratings are those values beyond which the device could be permanently damaged.

Absolute maximum ratings are stress ratings only and functional device operation is not implied.

2. Repetitive Rating : Pulse width limited by T_J .

3. $L=50\text{mH}$, $I_{AS}=2.0\text{A}$, $V_{DD}=50\text{V}$, $R_G=25\ \Omega$, Starting $T_J = 25^\circ\text{C}$

4. $I_{SD}\leq 2.0\text{A}$, $di/dt\leq 200\text{A}/\mu\text{s}$, $V_{DD}\leq BV_{DSS}$, Starting $T_J = 25^\circ\text{C}$

■ THERMAL DATA

| PARAMETER | | SYMBOL | RATINGS | UNIT |
|---------------------|--|---------------|---------|---------------------------|
| Junction to Ambient | TO-220F/TO-220F1/ TO-220F2/TO-220F3 | θ_{JA} | 62.5 | $^\circ\text{C}/\text{W}$ |
| | TO-251/TO-251S TO-252/TO-252D | | 110 | $^\circ\text{C}/\text{W}$ |
| Junction to Case | TO-220F/TO-220F1 TO-220F3 | θ_{JC} | 4.46 | $^\circ\text{C}/\text{W}$ |
| | TO-220F2 | | 4.35 | $^\circ\text{C}/\text{W}$ |
| | TO-251/TO-251S TO-252/TO-252D | | 4.24 | $^\circ\text{C}/\text{W}$ |

■ ELECTRICAL CHARACTERISTICS ($T_J=25^{\circ}\text{C}$, unless otherwise specified)

| PARAMETER | SYMBOL | TEST CONDITIONS | MIN | TYP | MAX | UNIT |
|---|------------------------------|---|-----|------|------|----------------------|
| OFF CHARACTERISTICS | | | | | | |
| Drain-Source Breakdown Voltage | BV_{DSS} | $V_{GS} = 0V, I_D = 250\mu A$ | 700 | | | V |
| Drain-Source Leakage Current | I_{DSS} | $V_{DS} = 700V, V_{GS} = 0V$ | | | 10 | μA |
| Gate-Source Leakage Current | Forward | I_{GSS} | | | 100 | nA |
| | Reverse | | | | -100 | nA |
| Breakdown Voltage Temperature Coefficient | $\Delta BV_{DSS}/\Delta T_J$ | $I_D = 250 \mu A$, Referenced to 25°C | | 0.4 | | $V/^{\circ}\text{C}$ |
| ON CHARACTERISTICS | | | | | | |
| Gate Threshold Voltage | $V_{GS(TH)}$ | $V_{DS} = V_{GS}, I_D = 250\mu A$ | 3.0 | | 5.0 | V |
| Static Drain-Source On-State Resistance | $R_{DS(ON)}$ | $V_{GS} = 10V, I_D = 1.0A$ | | | 5.5 | Ω |
| DYNAMIC CHARACTERISTICS | | | | | | |
| Input Capacitance | C_{ISS} | $V_{DS} = 25V, V_{GS} = 0V, f = 1\text{MHz}$ | | 258 | | pF |
| Output Capacitance | C_{OSS} | | | 31 | | pF |
| Reverse Transfer Capacitance | C_{RSS} | | | 4.6 | | pF |
| SWITCHING CHARACTERISTICS | | | | | | |
| Turn-On Delay Time | $t_{D(ON)}$ | $V_{DD} = 30V, I_D = 0.5A, R_G = 25\Omega$ (Note 1, 2) | | 39.5 | | ns |
| Turn-On Rise Time | t_R | | | 38.5 | | ns |
| Turn-Off Delay Time | $t_{D(OFF)}$ | | | 50 | | ns |
| Turn-Off Fall Time | t_F | | | 21 | | ns |
| Total Gate Charge | Q_G | $V_{DS} = 50V, I_D = 1.3A, V_{GS} = 10V$ (Note 1, 2) | | 10.4 | | nC |
| Gate-Source Charge | Q_{GS} | | | 5.3 | | nC |
| Gate-Drain Charge | Q_{GD} | | | 2.0 | | nC |
| DRAIN-SOURCE DIODE CHARACTERISTICS | | | | | | |
| Drain-Source Diode Forward Voltage | V_{SD} | $V_{GS} = 0V, I_{SD} = 2.0A$ | | | 1.4 | V |
| Continuous Drain-Source Current | I_{SD} | | | | 2.0 | A |
| Pulsed Drain-Source Current | I_{SM} | | | | 8.0 | A |

Notes: 1. Pulse Test: Pulse width $\leq 300\mu s$, Duty cycle $\leq 2\%$
 2. Essentially independent of operating temperature

■ TEST CIRCUITS AND WAVEFORMS

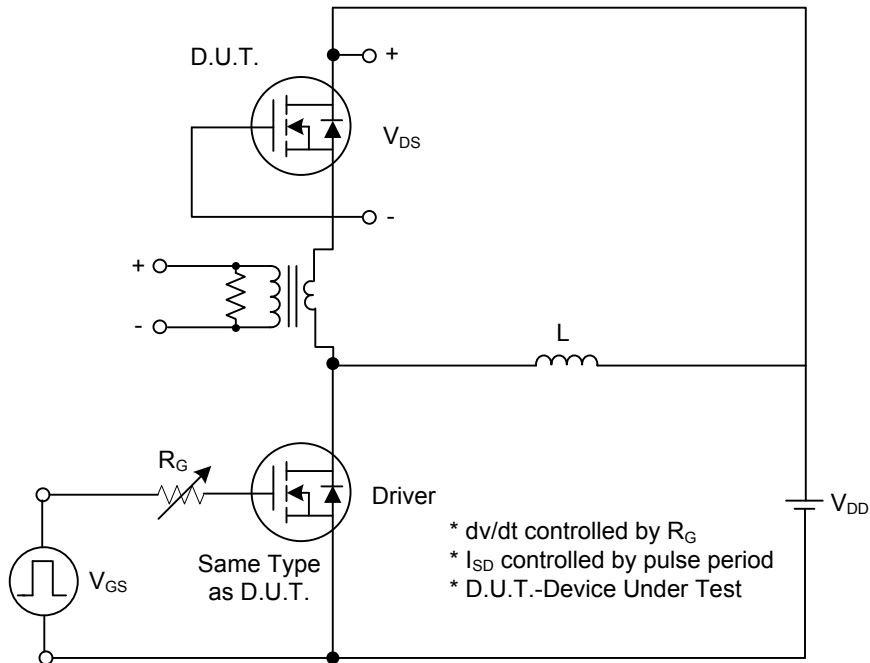

Fig. 1A Peak Diode Recovery dv/dt Test Circuit

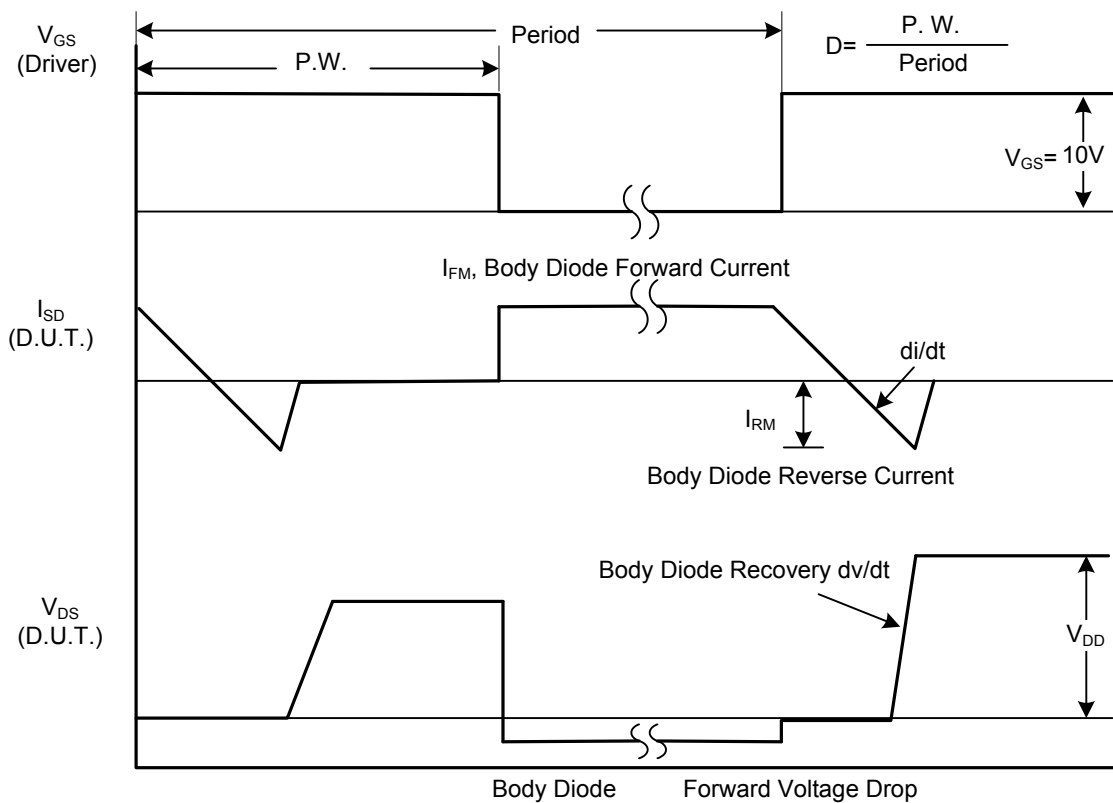

Fig. 1B Peak Diode Recovery dv/dt Waveforms

TEST CIRCUITS AND WAVEFORMS (Cont.)

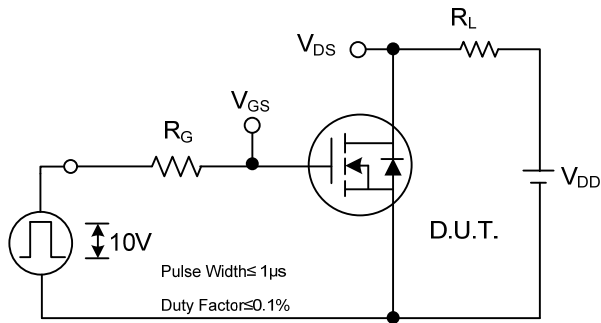

Fig. 2A Switching Test Circuit

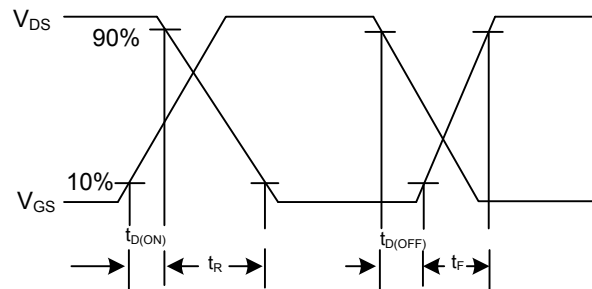

Fig. 2B Switching Waveforms

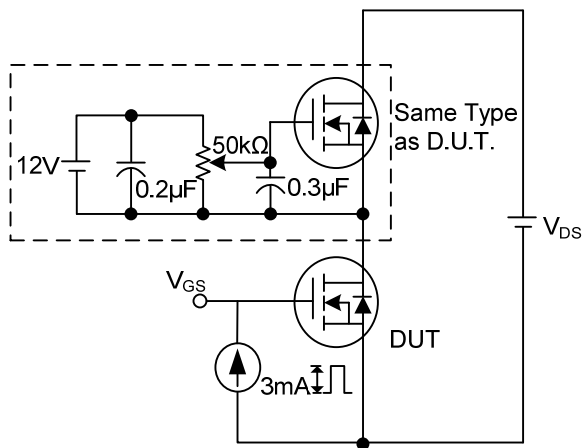

Fig. 3A Gate Charge Test Circuit

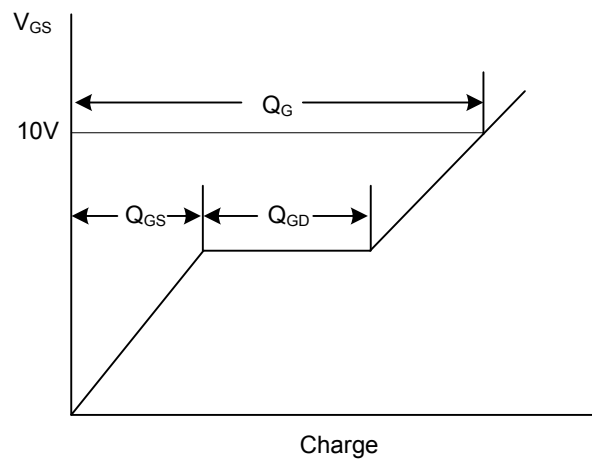

Fig. 3B Gate Charge Waveform

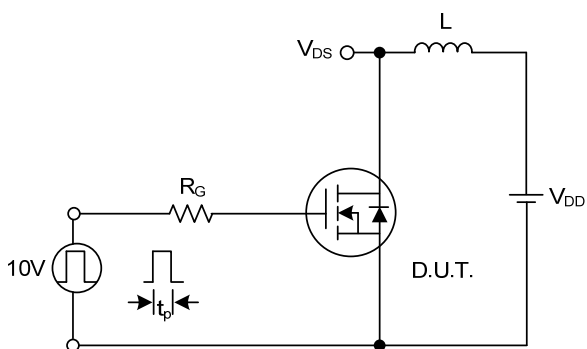

Fig. 4A Unclamped Inductive Switching Test Circuit

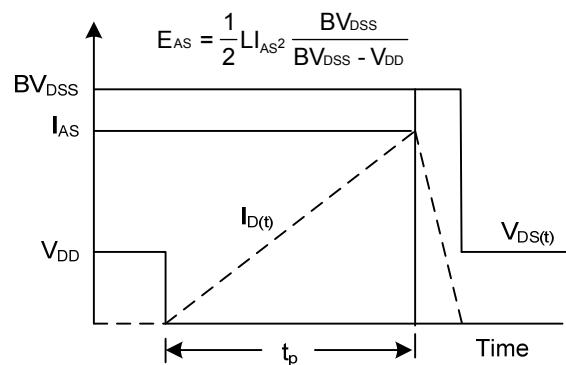
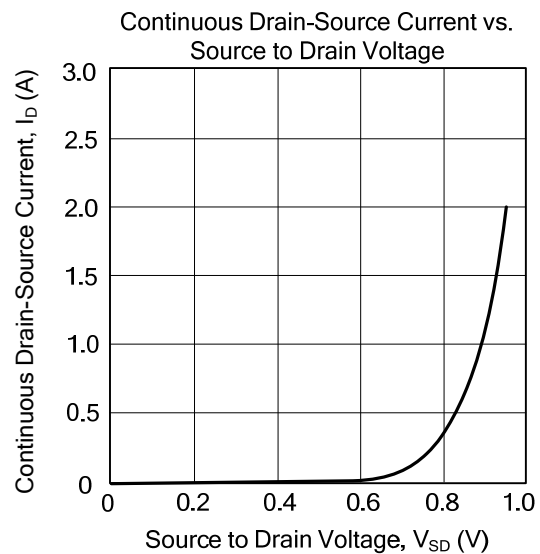
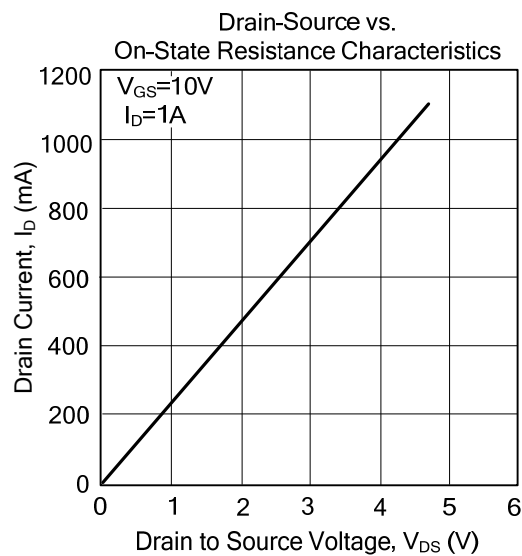
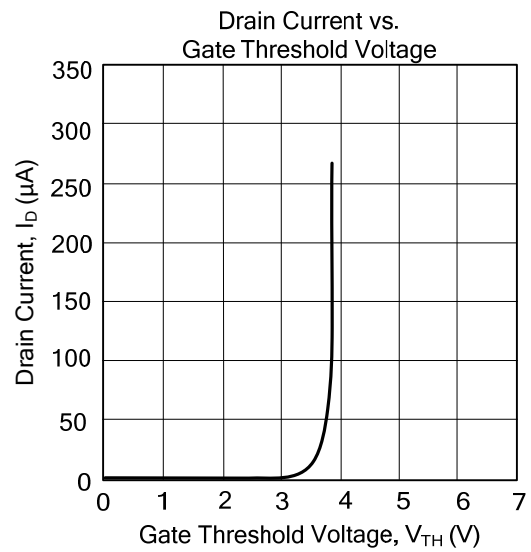
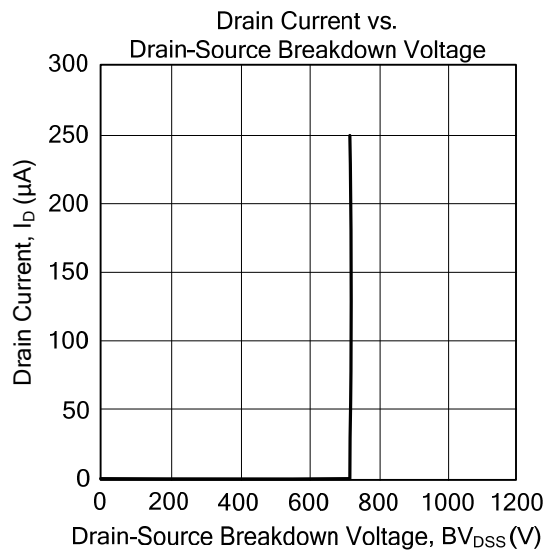

Fig. 4B Unclamped Inductive Switching Waveforms

■ TYPICAL CHARACTERISTICS



UTC assumes no responsibility for equipment failures that result from using products at values that exceed, even momentarily, rated values (such as maximum ratings, operating condition ranges, or other parameters) listed in products specifications of any and all UTC products described or contained herein. UTC products are not designed for use in life support appliances, devices or systems where malfunction of these products can be reasonably expected to result in personal injury. Reproduction in whole or in part is prohibited without the prior written consent of the copyright owner. The information presented in this document does not form part of any quotation or contract, is believed to be accurate and reliable and may be changed without notice.