



NON-ISOLATED BUCK OFFLINE LED DRIVER

DESCRIPTION

The UTC **USL3631** is a high performance, high precision and low cost constant current LED driver for non-isolated buck application. The device operates in critical conduction mode and is suitable for 85V~265V universal input offline LED lighting. It operates in critical conduction mode, the output current does not change with the inductance and LED output voltage.

The UTC **USL36313** integrates a 600V power MOSFET. It can achieve excellent constant current performance with very few external components, so the system cost and size are minimized.

The UTC **USL3631** offers rich protection functions to improve the system reliability, including LED open circuit protection, LED short circuit protection, V_{CC} under voltage protection, CS resistor short circuit protection and thermal regulation function.

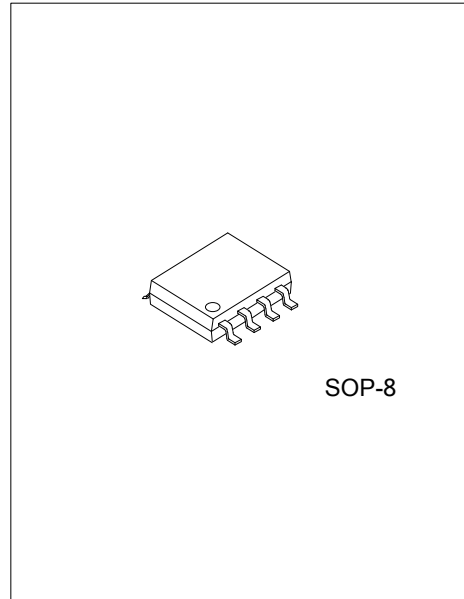

FEATURES

- * Critical conduction mode operation
- * Internal 600V Power MOSFET
- * Ultra low operating current
- * No auxiliary winding
- * ±5% LED output current accuracy
- * LED short protection
- * LED open protection
- * V_{CC} under voltage protection
- * Current sensing resistor short protection
- * Thermal regulation function

ORDERING INFORMATION

Ordering Number		Package	Packing
Lead Free	Halogen Free		
USL3631L-S08-R	USL3631G-S08-R	SOP-8	Tape Reel

<p>USL3631G-S08-R</p> <ul style="list-style-type: none"> (1) Packing Type (2) Package Type (3) Green Package 	<p>(1) R: Tape Reel (2) S08: SOP-8 G: Halogen Free and Lead Free, L: Lead Free</p>
---	--

MARKING

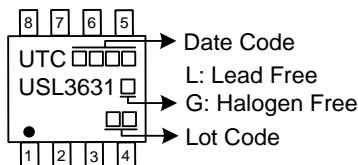

PIN CONFIGURATION

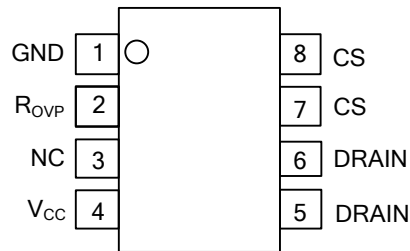

PIN DESCRIPTION

PIN NO.	PIN NAME	DESCRIPTION
1	GND	Ground
2	R _{OVP}	Over voltage protection setting pn. Connect a resistor to GND
3	NC	No connection. Should be connected to GND(Pin1)
4	V _{CC}	Power supply pin
5, 6	DRAIN	Internal HV Power MOSFET Drain.
7, 8	CS	Current sense pin. Connect a sense resistor between this pin and GND pin.

BLOCK DIAGRAM

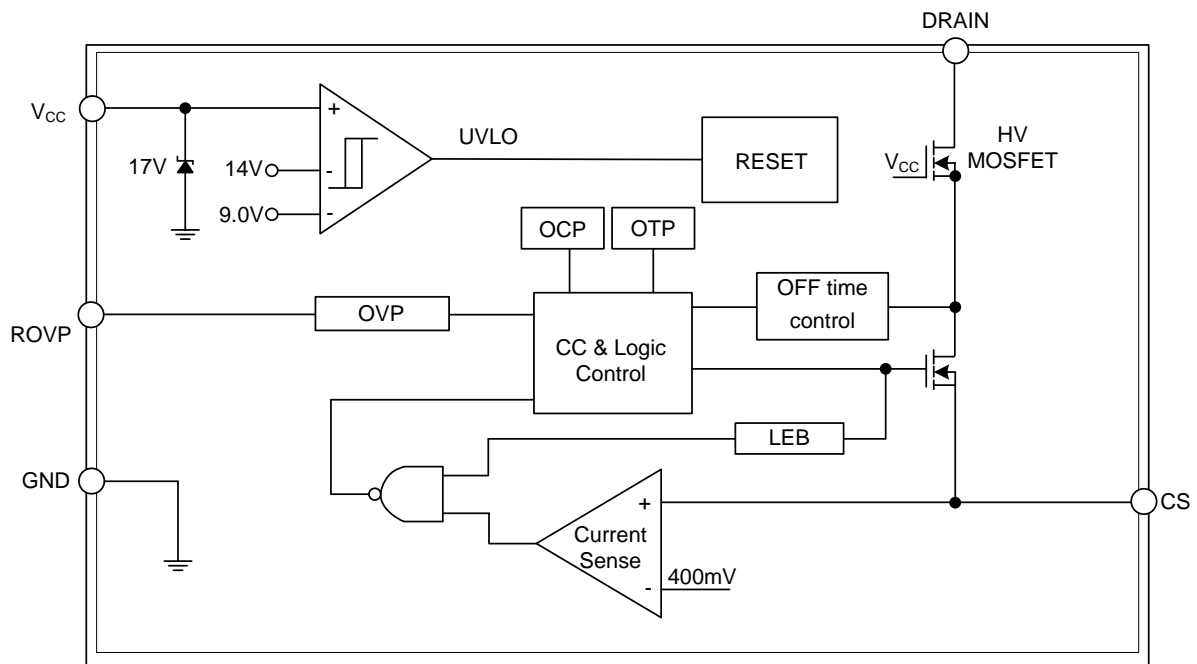

■ ABSOLUTE MAXIMUM RATING

PARAMETER	SYMBOL	RATINGS	UNIT
V _{CC} Pin Maximum Sink Current	I _{CC_MAX}	5	mA
Internal HV MOSFET Drain Voltage	DRAIN	-0.3 ~ 600	V
Current Sense Pin Input Voltage	CS	-0.3 ~ 6	V
Over-Voltage Setting Pin Voltage	R _{OV} P	-0.3 ~ 6	V
Power Dissipation	P _D	0.45	W
Junction Temperature	T _J	-40 ~ +150	°C
Storage Temperature	T _{STG}	-55 ~ +150	°C

Note: Absolute maximum ratings are those values beyond which the device could be permanently damaged.

Absolute maximum ratings are stress ratings only and functional device operation is not implied.

■ RECOMMENDED OPERATION CONDITIONS

PARAMETER	SYMBOL	RATINGS	UNIT
Output LED Current @ V _{OUT} =72V (Input Voltage 176V~265V)	I _{LED1}	160	mA
Output LED Current @ V _{OUT} =36V (Input Voltage 176V~265V)	I _{LED2}	220	mA
Minimum LED Loading Voltage	V _{LED_min}	>15	V

■ THERMAL DATA

PARAMETER	SYMBOL	RATING	UNIT
Junction to Ambient	θ _{JA}	150	°C/W

■ ELECTRICAL CHARACTERISTICS (NOTE 1, 2) (V_{CC}=14V, T_A=25°C unless otherwise specified)

PARAMETER	SYMBOL	TEST CONDITIONS	MIN	TYP	MAX	UNIT
Supply Voltage Section						
V _{CC} Clamp Voltage	V _{CC_CLAMP}	1mA		16.8		V
V _{CC} Turn On Threshold	V _{CC_ON}	V _{CC} Rising		13.8		V
V _{CC} Turn Off Threshold	V _{CC_UVLO}	V _{CC} Falling		9		V
V _{CC} Startup Current	I _{ST}	V _{CC} = V _{CC-ON} - 1V		180	280	μA
V _{CC} Operating Current	I _{OP}	F _{OP} =70KHz		200	300	μA
Current Sense Section						
Threshold Voltage for Peak Current Limit	V _{CS_peak}		390	400	410	mV
Threshold Voltage for Peak Current Limit When Output Short	V _{CS_SHORT}	Output Short		200		mV
Leading Edge Blanking Time for Current Sense	T _{LEB}			350		ns
Switch Off Delay Time	T _{DELAY}			200		ns
Internal Time Control Section						
Minimum OFF Time	T _{OFF_MIN}			4.5		μs
Maximum OFF Time	T _{OFF_MAX}			240		μs
Maximum On Time	T _{ON_MAX}			35		μs
R _{OV} P Pin Voltage	V _{ROVP}			0.5		V
MOSFET Section						
Static Drain-source On-resistance	R _{DS_ON}	V _{GS} =15V/I _{DS} =0.4A		14		Ω
Drain-Source Breakdown Voltage	BV _{DSS}	V _{GS} =0V/I _{DS} =250μA	600			V
Power MOSFET Drain Leakage Current	I _{DSS}	V _{GS} =0V/V _{DS} =600V			1	μA
Thermal Regulation Section						
Thermal Regulation Temperature	T _{REG}			150		°C

Notes: 1. Production testing of the chip is performed at 25°C.

2. The maximum and minimum parameters specified are guaranteed by test, the typical value are guaranteed by design, characterization and statistical analysis.

■ APPLICATION INFORMATION

The UTC **USL3631** is a high performance non-isolated Buck converter specially designed for LED lighting. The device integrates a 600V power MOSFET. With very few external components, the converter achieves excellent constant current control. And it does not need auxiliary winding for powering the IC or voltage sensing, thus the system size and cost is greatly reduced.

Start Up

When system powered up, the V_{CC} pin capacitor is charged up by the start up resistor. When the V_{CC} pin voltage reaches the start up threshold, the internal circuits start operating. The UTC **USL3631** integrates a 17V zener diode to clamp the V_{CC} voltage.

Constant Current Control

Cycle by Cycle current sense is adjusted in UTC **USL3631**, the CS pin is connected to the current sense comparator, and the voltage on CS pin is compared with the internal 400mV reference voltage. The MOSFET will be switched off when the voltage on CS pin reaches the Peak Current threshold. The CS comparator includes a 350ns leading edge blanking time. After the MOSFET switched off, the OFF time controller would open the MOSFET again at time up. At that moment, CS pin voltage is 0mV usually.

The Delta inductor current is given by:

$$I_{PK} = \frac{400}{R_{CS}} \text{ (mA)}$$

Where, R_{CS} is the current sense resistor value.

The current in LED can be calculated by the equation:

$$I_{LED} = \frac{I_{PK}}{2} = \frac{200}{R_{CS}} \text{ (mA)}$$

Where, I_{PK} is the Peak current of the inductor.

Inductor Selection

The UTC **USL3631** works under inductor current critical conduction mode. When the power MOSFET is switched on, the current in the inductor rises up from zero, the on time of the MOSFET can be calculated by the equation:

$$t_{on} = \frac{L \times I_{PK}}{V_{IN} - V_{LED}}$$

Where,

L is the inductance value

V_{IN} is the DC bus voltage after the rectifier bridge

V_{LED} is the voltage on the LED

After the power MOSFET is switched off, the current in the inductor decreases. When the inductor current reaches zero, the power MOSFET is turned on again by IC internal logic. The off time of the MOSFET is given by:

$$t_{off} = \frac{L \times I_{PK}}{V_{LED}}$$

The inductance can be calculated by the equation:

$$L = \frac{V_{LED} \times (V_{IN} - V_{LED})}{freq \times I_{PK} \times V_{IN}}$$

The freq is the system switching frequency, which is proportional to the input voltage. So the minimum switching frequency is set at lowest input voltage, and the maximum switching frequency is set at highest input voltage.

The minimum and maximum off time of UTC **USL3631** is set at 4.5 μ s and 240 μ s, respectively. Referring to the equation of t_{OFF} calculation, if the inductance is too small, the t_{OFF} may be smaller than the minimum off time, system will operate in discontinuous conduction mode and the output current will be smaller than the designed value. If the inductance is too large, the t_{OFF} may be larger than the maximum off time, the output current will not be constant follow design value. So it is important to choose a proper inductance, we recommend user to regulate the inductance value for 70KHz application.

■ APPLICATION INFORMATION (Cont.)

Over Voltage Protection

The over voltage protection can be programmed by the R_{OVP} pin resistor. The R_{OVP} pin voltage is 0.5V.

When the LED is open circuit, the output voltage increases gradually, and the demagnetization time gets shorter. The demagnetization time at OVP---- T_{ovp} can be calculated by the open circuit protection voltage:

$$T_{OVP} \approx \frac{L \times I_{PK}}{V_{OVP}}$$

Where,

V_{ovp} is the open circuit protection voltage

And then the R_{ovp} resistor value can be calculated by the equation:

$$R_{OVP} \approx 19 \times T_{ovp} \times 10^6 \quad (\text{k}\Omega)$$

Protection Function

The UTC **USL3631** offers rich protection functions to improve the system reliability, including LED open/short protection, CS resistor short protection, V_{CC} under voltage protection, thermal regulation. When the LED is open circuit, the system will trigger the over voltage protection and stop switching.

When the LED short circuit is detected, the system works at low frequency (about 5kHz), and the CS pin turn off threshold is reduced to 200mV. So the system power consumption is very low. At some catastrophic fault condition, such as CS resistor shorted or inductor saturated, the internal fast fault detection circuit will be triggered, the system stops switching immediately.

After the system enters into fault condition, the V_{CC} voltage will decrease until it reaches the UVLO threshold, then the system will re-start again. If the fault condition is removed, the system will recover to normal operation.

Thermal Regulation

The UTC **USL3631** integrates thermal regulation function. When the system is over temperature, the output current is gradually reduced; the output power and thermal dissipation are also reduced. The system temperature is regulated and the system reliability is improved. The thermal regulation temperature is set to 150°C internally.

PCB Layout

The following rules should be followed in UTC **USL3631** PCB layout:

Bypass Capacitor

The bypass capacitor on V_{CC} pin should be as close as possible to the V_{CC} Pin and GND pin.

R_{OVP} Pin

The R_{OVP} resistor should be as close as possible to the R_{OVP} Pin.

Ground Path

The power ground path for current sense should be short, and the power ground path should be separated from small signal ground path before connecting to the negative node of the bulk capacitor.

The Area of Power Loop

The area of main current loop should be as small as possible to reduce EMI radiation, such as the inductor, the power MOSFET, the output diode and the bus capacitor loop.

NC pin

The NC pin should be connected to GND (pin1).

Drain Pin

To increase the copper area of DRAIN pin for better thermal dissipation. However too large copper area may compromise EMI performance.

■ TYPICAL APPLICATION CIRCUIT

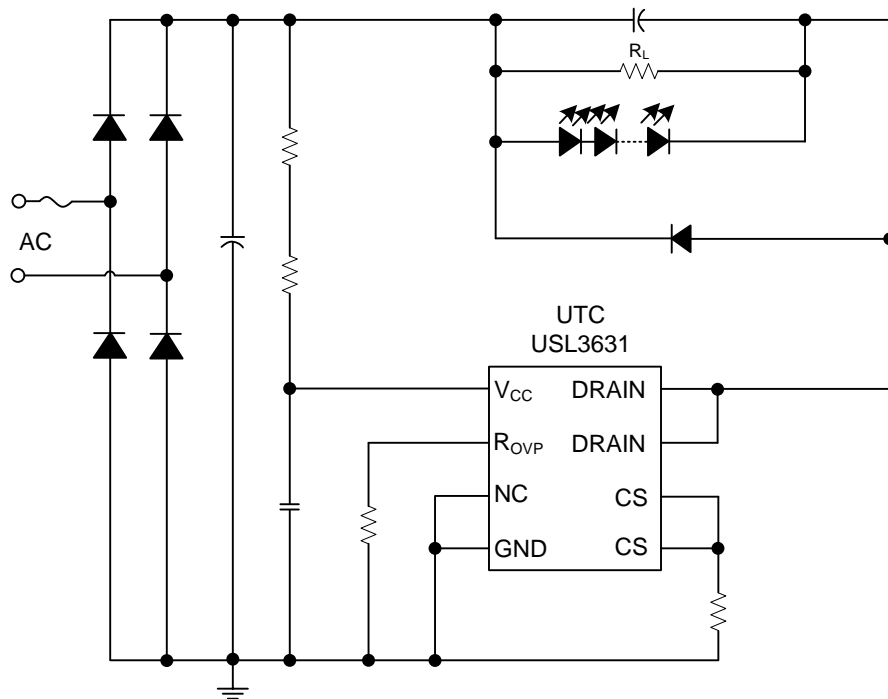

UTC assumes no responsibility for equipment failures that result from using products at values that exceed, even momentarily, rated values (such as maximum ratings, operating condition ranges, or other parameters) listed in products specifications of any and all UTC products described or contained herein. UTC products are not designed for use in life support appliances, devices or systems where malfunction of these products can be reasonably expected to result in personal injury. Reproduction in whole or in part is prohibited without the prior written consent of the copyright owner. UTC reserves the right to make changes to information published in this document, including without limitation specifications and product descriptions, at any time and without notice. This document supersedes and replaces all information supplied prior to the publication hereof.