



USL1650

Preliminary

LINEAR INTEGRATED CIRCUIT

HIGH EFFICIENCY PWM BUCK LED DRIVER CONTROLLER

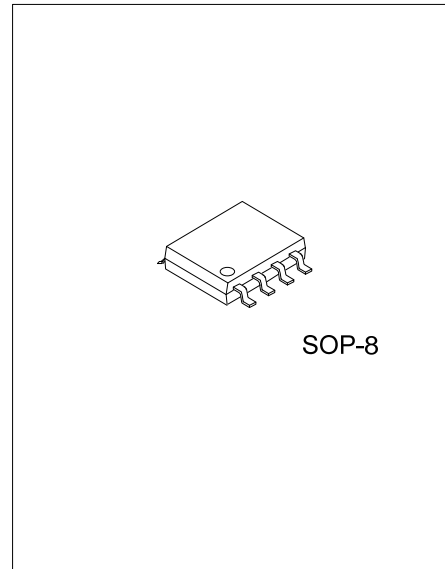

DESCRIPTION

The UTC **USL1650** is a PWM mode step-down converter (with a high voltage power MOSFET with SOP8 package). By well regulating a constant output current. The output duty cycle of the UTC **USL1650** can be up to 100% for wider input voltage application.

The UTC **USL1650** is available in a SOP-8 package.

FEATURES

- * Universal input voltage range with off-line topology
- * Programmable constant LED current
- * Output LED string short protection
- * Output LED string open protection
- * Dimmable LED current by ACTL
- * OCP
- * Built-in OTP

ORDERING INFORMATION

Ordering Number	Package	Packing
USL1650G-S08-R	SOP-8	Tape Reel

<p>USL1650G-S08-R</p> <p>(1)Packing Type.</p> <p>(2)Package Type</p> <p>(3)Green Package</p>	<p>(1) R: Tape Reel</p> <p>(2) S08: SOP-8</p> <p>(3) G: Halogen Free and Lead Free</p>
--	--

MARKING

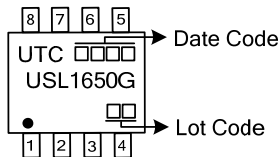

■ PIN CONFIGURATIONS

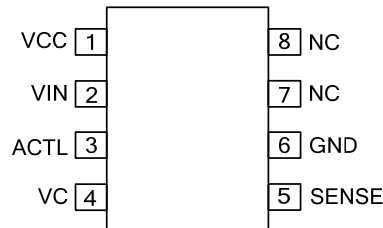

■ PIN DESCRIPTION

PIN NO.	PIN NAME	DESCRIPTION
1	V _{CC}	Power supply.
2	V _{IN}	Power MOS drain.
3	ACTL	Analog dimming control.
4	V _C	Compensation pin.
5	SENSE	LED current sense input pin.
6	GND	Ground of the chip.
7, 8	NC	

■ BLOCK DIAGRAM

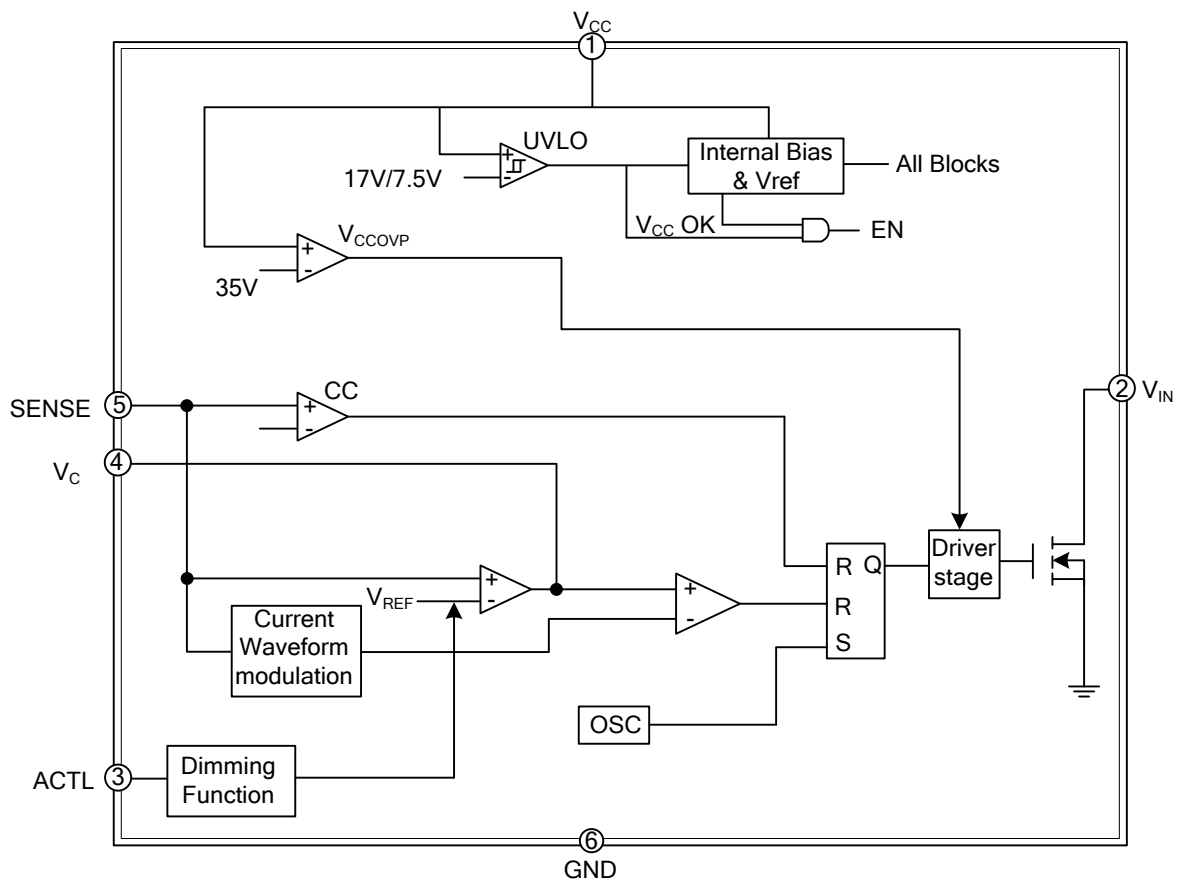

■ ABSOLUTE MAXIMUM RATING

PARAMETER	SYMBOL	RATINGS	UNIT
Supply Input Voltage	V_{CC}	40	V
GATE Voltage	V_{GATE}	14	V
ACTL Voltage (Note 1)	V_{ACTL}	8	V
VC Voltage	V_{VC}	6	V
SENSE Voltage	V_{SENSE}	-0.3~6	V
Power Dissipation	$T_A=25^{\circ}C$ P_D	0.392	W
Junction Temperature	T_J	150	$^{\circ}C$
Storage Temperature	T_{STG}	-65~+150	$^{\circ}C$

Notes: 1. Absolute maximum ratings are those values beyond which the device could be permanently damaged.

Absolute maximum ratings are stress ratings only and functional device operation is not implied.

2. If the ACTL pin is connected with a serial 1M Ω resistor, the maximum voltage can go up to 36V.

■ RECOMMENDED OPERATING CONDITIONS (Note)

PARAMETER	SYMBOL	RATINGS	UNIT
Supply Input Voltage	V_{CC}	17~32	V
Junction Temperature Range	T_J	-40~125	$^{\circ}C$

Note: The device is not guaranteed to function outside its operating conditions.

■ THERMAL DATA

PARAMETER	SYMBOL	RATING	UNIT
Junction to Ambient	θ_{JA}	225	$^{\circ}C/W$

■ ELECTRICAL CHARACTERISTICS ($V_{CC}=24V_{DC}$, $T_A=25^{\circ}C$, unless otherwise specified)

PARAMETER	SYMBOL	TEST CONDITIONS	MIN	TYP	MAX	UNIT
Input Start-Up Voltage	V_{ST}		15	17	19	V
Minimum Operation Voltage After Start-Up	$V_{IN(MIN)}$		6.0	7.5	9.0	V
Input Quiescent Current	I_{QC}	After Start-Up, $V_{CC}=24V$		1.65	5.0	mA
Maximum Startup Current in V_{CC} Hiccup Operation	$I_{ST(MAX)}$	Maximum I_{CC} at Low End of V_{CC}		250	300	μA
Input Shutdown Current	I_{SHDN}	Before Start-Up, $V_{CC}=15V$		0.1	5.0	μA
Over Voltage Protection	V_{OVP}	V_{CC} Pin	32.5	35.5	36.5	V
Current Sense Voltage	V_{SENSE}			160		mV
Switching Frequency	f_{SW}		38	47	55	kHz
Oscillator Maximum Duty Cycle	D_{MAX}	$V_C=3V$			100	%
Minimum Turn-On Time	$t_{ON(MIN)}$		300			ns
Power MOSFET						
Static Drain-Source On-State Resistance	$R_{DS(ON)}$	$V_{GS}=10V$, $I_D=0.5A$		11.5	15.5	Ω
Drain-Source Voltage	V_{DSS}	$V_{GS}=0V$	650			V
Drain-Source Leakage Current	I_{DSS}	$V_{DS}=650V$, $V_{GS}=0V$			10	μA
ACTL LED Dimming						
Analog Dimming ACTL Pin Input Current	I_{ACTL}			1	5	μA
Analog Dimming Range			0		1.3	V
Analog Dimming	High Level			1.2	1.3	V
Threshold Voltage	Low Level		0	0.1		V
VC Threshold for PWM Switch Off	V_{VC}		1.1	1.25	1.4	V
Thermal Protection						
Thermal Shutdown Temperature	T_{SD}		150			$^{\circ}C$

■ TYPICAL APPLICATION CIRCUIT

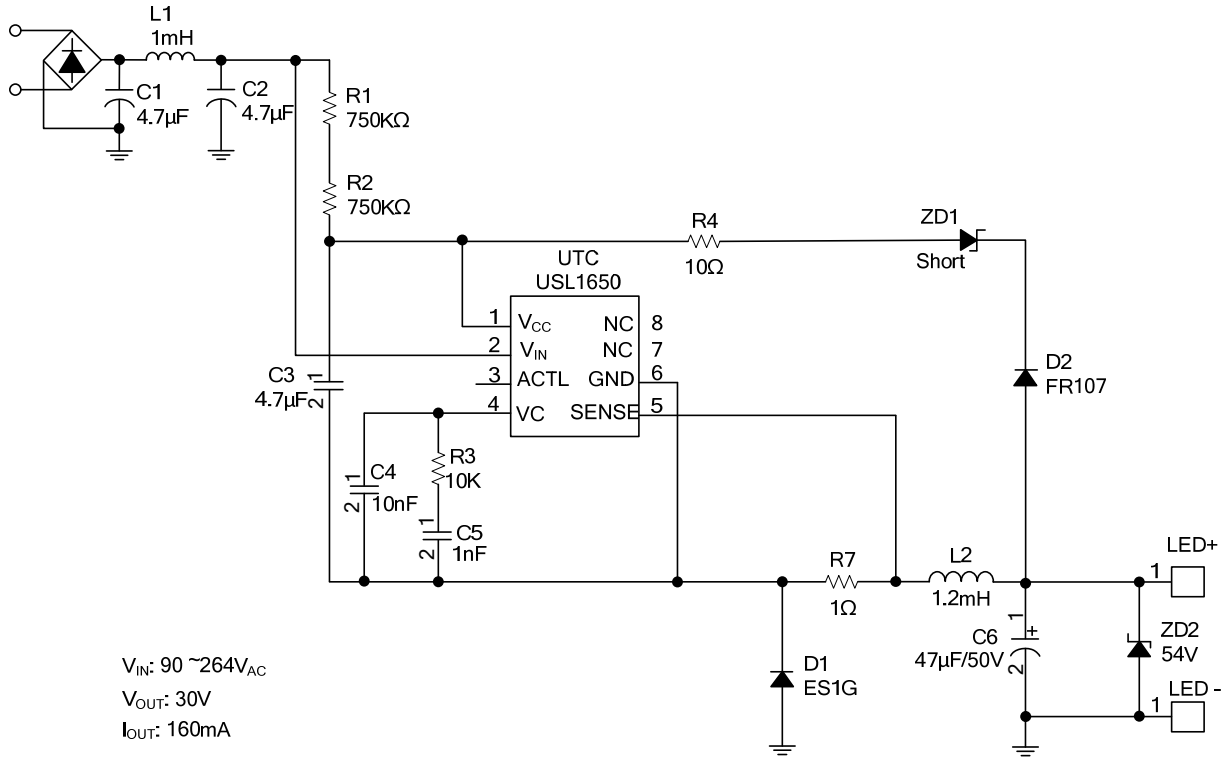

UTC assumes no responsibility for equipment failures that result from using products at values that exceed, even momentarily, rated values (such as maximum ratings, operating condition ranges, or other parameters) listed in products specifications of any and all UTC products described or contained herein. UTC products are not designed for use in life support appliances, devices or systems where malfunction of these products can be reasonably expected to result in personal injury. Reproduction in whole or in part is prohibited without the prior written consent of the copyright owner. The information presented in this document does not form part of any quotation or contract, is believed to be accurate and reliable and may be changed without notice.