



**6N70-C**

Preliminary

**Power MOSFET**

**6.0A, 700V N-CHANNEL  
POWER MOSFET**

■ DESCRIPTION

The UTC **6N70-C** is an N-channel mode power MOSFET using UTC's advanced technology to provide customers with a minimum on-state resistance, high switching speed, low gate charge and low input capacitance.

The UTC **6N70-C** is universally applied in high efficiency switch mode power supply.

■ FEATURES

- \*  $R_{DS(ON)} < 1.8\Omega @ V_{GS}=10V, I_D=3A$
- \* High switching speed

■ SYMBOL

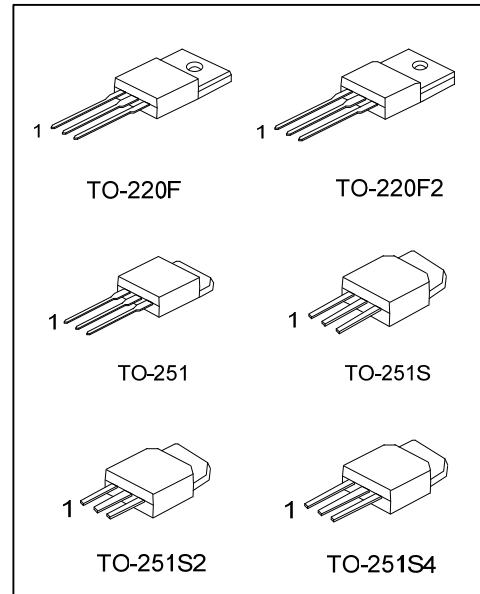
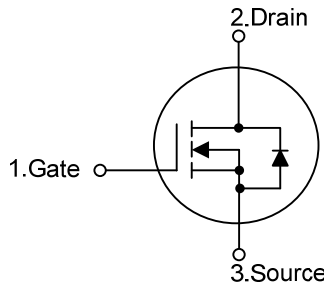

■ ORDERING INFORMATION

Ordering Number		Package	Pin Assignment			Packing
Lead Free	Halogen Free		1	2	3	
6N70L-TF3-T	6N70G-TF3-T	TO-220F	G	D	S	Tube
6N70L-TF2-T	6N70G-TF2-T	TO-220F2	G	D	S	Tube
6N70L-TM3-T	6N70G-TM3-T	TO-251	G	D	S	Tube
6N70L-TMS-T	6N70G-TMS-T	TO-251S	G	D	S	Tube
6N70L-TMS2-T	6N70G-TMS2-T	TO-251S2	G	D	S	Tube
6N70L-TMS4-T	6N70G-TMS4-T	TO-251S4	G	D	S	Tube

Note: Pin Assignment: G: Gate D: Drain S: Source

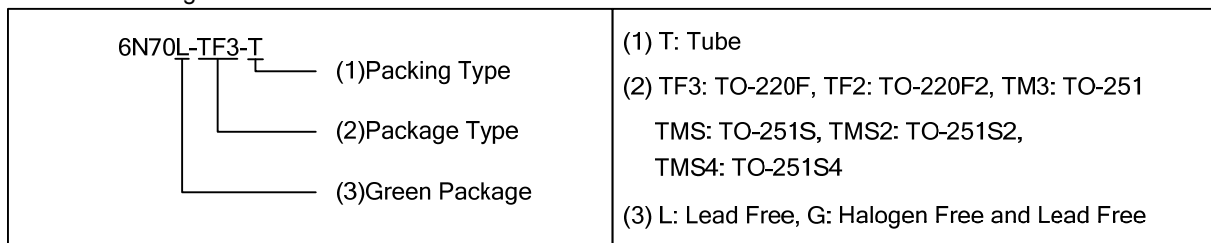

■ MARKING

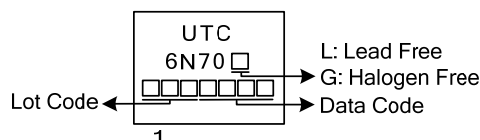

■ ABSOLUTE MAXIMUM RATINGS (unless otherwise specified)

PARAMETER		SYMBOL	RATINGS	UNIT	
Drain-Source Voltage		$V_{DSS}$	700	V	
Gate-Source Voltage (Note 2)		$V_{GSS}$	$\pm 30$	V	
Drain Current	Continuous	$I_D$	$T_C=25^\circ\text{C}$	6	A
			$T_C=100^\circ\text{C}$	3.8	A
	Pulsed		$I_{DM}$	24	A
Avalanche Current (Note 2)		$I_{AR}$	6	A	
Avalanche Energy	Single Pulsed (Note 3)	$E_{AS}$	108	mJ	
	Repetitive (Note 2)	$E_{AR}$	13	mJ	
Peak Diode Recovery dv/dt (Note 4)		dv/dt	2.5	V/ns	
Power Dissipation	TO-220F	$P_D$	40	W	
	TO-220F2		42		
	TO-251/TO-251S		55		
	TO-251S2/TO-251S4				
Linear Derating Factor	TO-220F	$P_D$	0.32	W/ $^\circ\text{C}$	
	TO-220F2		0.33		
	TO-251/TO-251S		0.44		
	TO-251S2/TO-251S4				
Junction Temperature		$T_J$	+150	$^\circ\text{C}$	
Storage Temperature		$T_{STG}$	-55~+150	$^\circ\text{C}$	

Notes: 1. Absolute maximum ratings are those values beyond which the device could be permanently damaged.

Absolute maximum ratings are stress ratings only and functional device operation is not implied.

2. Repetitive Rating: Pulse width limited by maximum junction temperature

3.  $L = 6\text{mH}$ ,  $I_{AS} = 6\text{A}$ ,  $V_{DD} = 50\text{V}$ ,  $R_G = 27\Omega$ , Starting  $T_J = 25^\circ\text{C}$

4.  $I_{SD} \leq 6\text{A}$ ,  $di/dt \leq 140\text{A}/\mu\text{s}$ ,  $V_{DD} \leq BV_{DSS}$ , Starting  $T_J = 25^\circ\text{C}$

■ THERMAL DATA

PARAMETER		SYMBOL	RATINGS	UNIT
Junction to Ambient	TO-220F/TO-220F2	$\theta_{JA}$	62.5	$^\circ\text{C}/\text{W}$
	TO-251/TO-251S		110	$^\circ\text{C}/\text{W}$
	TO-251S2/TO-251S4			
Junction to Case	TO-220F	$\theta_{JC}$	3.1	$^\circ\text{C}/\text{W}$
	TO-220F2		2.9	$^\circ\text{C}/\text{W}$
	TO-251/TO-251S		2.27	$^\circ\text{C}/\text{W}$
	TO-251S2/TO-251S4			

■ ELECTRICAL CHARACTERISTICS ( $T_C=25^\circ\text{C}$ , unless otherwise specified)

PARAMETER	SYMBOL	TEST CONDITIONS	MIN	TYP	MAX	UNIT
<b>OFF CHARACTERISTICS</b>						
Drain-Source Breakdown Voltage	$BV_{DSS}$	$I_D=250\mu\text{A}$ , $V_{GS}=0\text{V}$	700			V
Breakdown Voltage Temperature Coefficient	$\Delta BV_{DSS}/\Delta T_J$	$I_D=250\mu\text{A}$		0.79		$V/^\circ\text{C}$
Drain-Source Leakage Current	$I_{DSS}$	$V_{DS}=700\text{V}$			25	$\mu\text{A}$
		$V_{DS}=560\text{V}$ , $T_C=125^\circ\text{C}$			250	$\mu\text{A}$
Gate-Source Leakage Current	Forward	$V_{GS}=+30\text{V}$ , $V_{DS}=0\text{V}$			+100	nA
	Reverse	$V_{GS}=-30\text{V}$ , $V_{DS}=0\text{V}$			-100	nA
<b>ON CHARACTERISTICS</b>						
Gate Threshold Voltage	$V_{GS(TH)}$	$V_{DS}=V_{GS}$ , $I_D=250\mu\text{A}$ , $V_{DS}=5\text{V}$	2.0		4.0	V
Static Drain-Source On-State Resistance	$R_{DS(ON)}$	$V_{GS}=10\text{V}$ , $I_D=3\text{A}$ (Note 1)		1.5	1.8	$\Omega$
<b>DYNAMIC PARAMETERS</b>						
Input Capacitance	$C_{ISS}$	$V_{GS}=0\text{V}$ , $V_{DS}=25\text{V}$ , $f=1.0\text{MHz}$ (Note 1, 2)		700	1000	pF
Output Capacitance	$C_{OSS}$			79	120	pF
Reverse Transfer Capacitance	$C_{RSS}$			6	13	pF
<b>SWITCHING PARAMETERS</b>						
Turn-ON Delay Time	$t_{D(ON)}$	$V_{DD}=30\text{V}$ , $I_D=1\text{A}$ , $R_G=25\Omega$		55	75	ns
Rise Time	$t_R$			50	70	ns
Turn-OFF Delay Time	$t_{D(OFF)}$			180	210	ns
Fall-Time	$t_F$			50	70	ns
Total Gate Charge	$Q_G$	$V_{GS}=10\text{V}$ , $V_{DS}=50\text{V}$ , $I_D=1.3\text{A}$ (Note 1, 2)		25	40	nC
Gate to Source Charge	$Q_{GS}$			6.5		nC
Gate to Drain Charge	$Q_{GD}$			4.8		nC
<b>SOURCE- DRAIN DIODE RATINGS AND CHARACTERISTICS</b>						
Maximum Body-Diode Continuous Current	$I_S$	Integral reverse pn-diode in the MOSFET			6	A
Maximum Body-Diode Pulsed Current (Note 3)	$I_{SM}$				24	A
Drain-Source Diode Forward Voltage (Note 2)	$V_{SD}$	$I_S=6\text{A}$ , $V_{GS}=0\text{V}$ , $T_J = 25^\circ\text{C}$			1.4	V

Notes: 1. Pulse Test: Pulse width  $\leq 250\mu\text{s}$ , Duty cycle  $\leq 2\%$

2. Essentially independent of operating temperature

3. Repetitive Rating: Pulse width limited by maximum junction temperature

■ TEST CIRCUITS AND WAVEFORMS

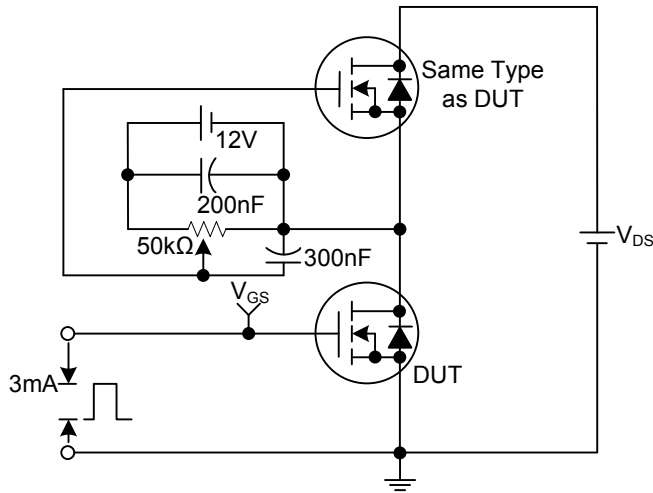

Gate Charge Test Circuit

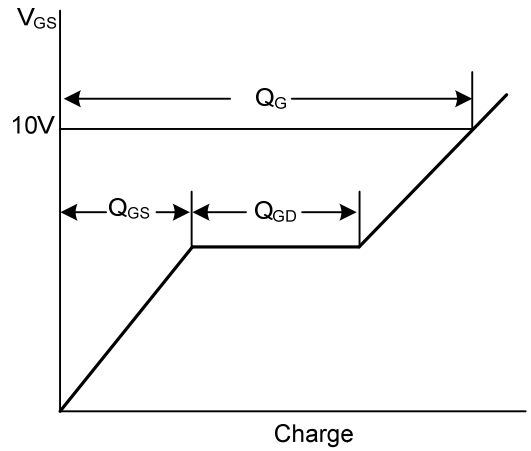

Gate Charge Waveforms

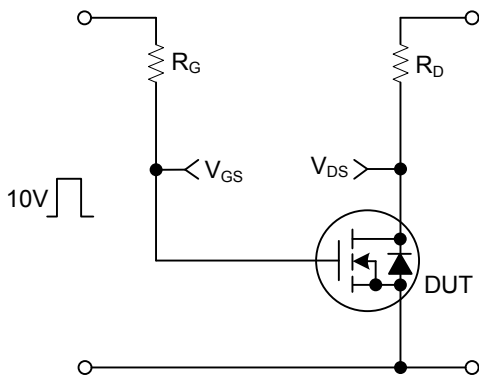

Resistive Switching Test Circuit

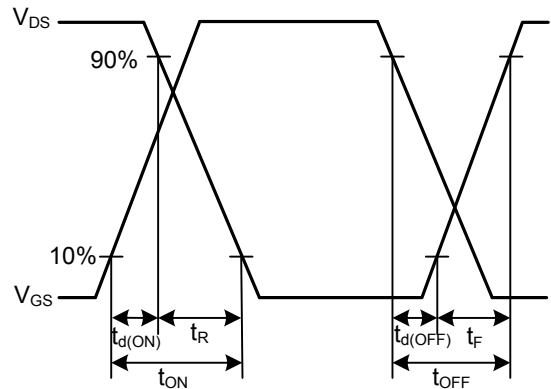

Resistive Switching Waveforms

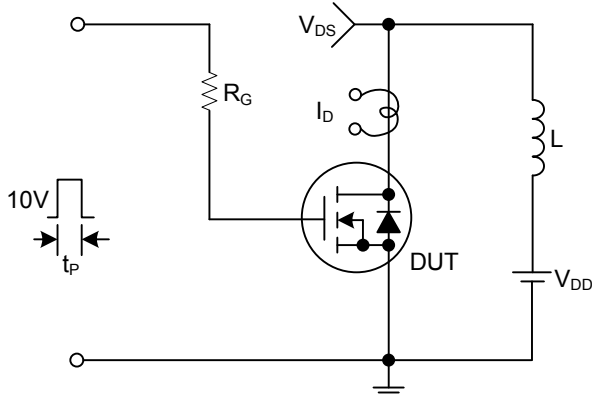

Unclamped Inductive Switching Test Circuit

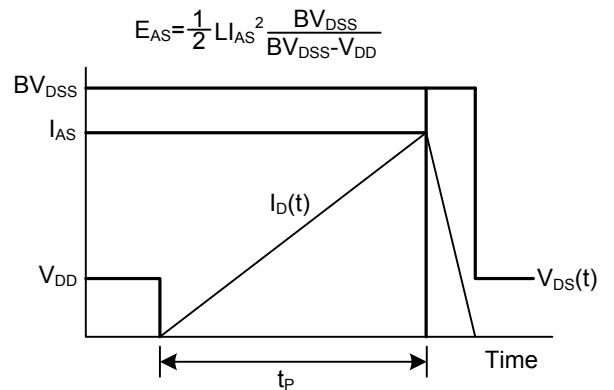

Unclamped Inductive Switching Waveforms

■ TEST CIRCUITS AND WAVEFORMS(Cont.)

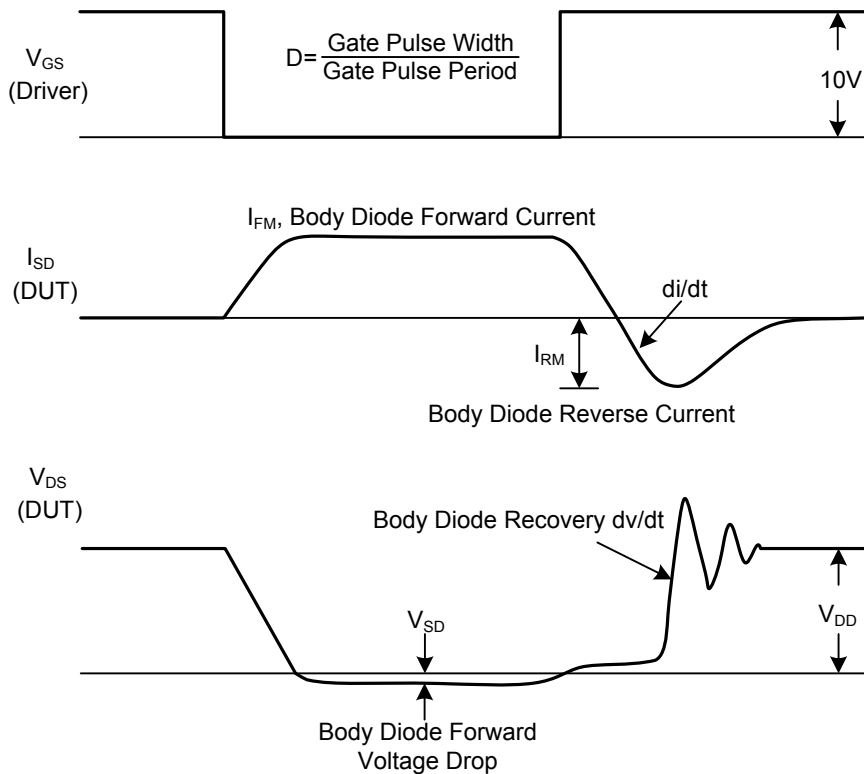
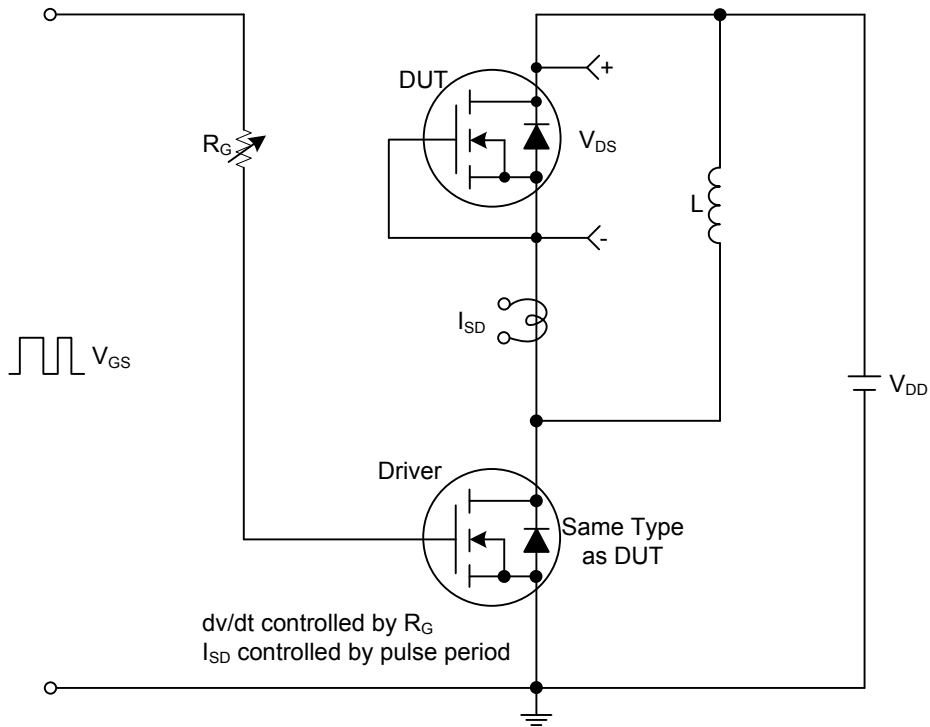

Peak Diode Recovery dv/dt Test Circuit and Waveforms

UTC assumes no responsibility for equipment failures that result from using products at values that exceed, even momentarily, rated values (such as maximum ratings, operating condition ranges, or other parameters) listed in products specifications of any and all UTC products described or contained herein. UTC products are not designed for use in life support appliances, devices or systems where malfunction of these products can be reasonably expected to result in personal injury. Reproduction in whole or in part is prohibited without the prior written consent of the copyright owner. The information presented in this document does not form part of any quotation or contract, is believed to be accurate and reliable and may be changed without notice.