



# 3N80Z

**Power MOSFET**

## 3A, 800V N-CHANNEL POWER MOSFET

■ DESCRIPTION

The UTC **3N80Z** provide excellent  $R_{DS(ON)}$ , low gate charge and operation with low gate voltages. This device is suitable for use as a load switch or in PWM applications.

■ FEATURES

- \*  $R_{DS(ON)} < 4.2\Omega$  @  $V_{GS}=10V, I_D=1.5A$
- \* Fast Switching Capability
- \* Avalanche Energy Specified
- \* Improved dv/dt Capability, High Ruggedness

■ SYMBOL

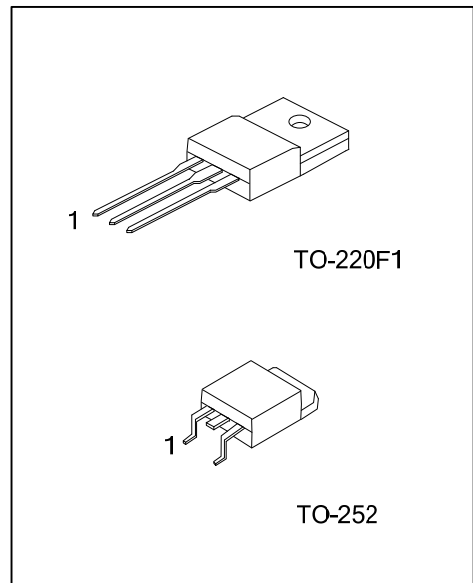
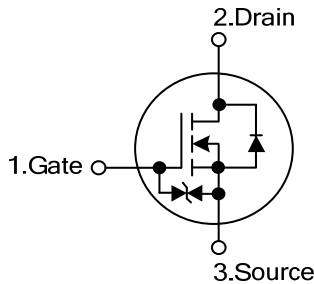

■ ORDERING INFORMATION

Ordering Number		Package	Pin Assignment			Packing
Lead Free	Halogen Free		1	2	3	
3N80ZL-TF1-T	3N80ZG-TF1-T	TO-220F1	G	D	S	Tube
3N80ZL-TN3-R	3N80ZG-TN3-R	TO-252	G	D	S	Tape Reel

Note: Pin Assignment: G: Gate D: Drain S: Source

<p>3N80ZG-TF1-T</p> <p>(1)Packing Type</p> <p>(2)Package Type</p> <p>(3)Green Package</p>	<p>(1) T: Tube, R: Tape Reel</p> <p>(2) TF1: TO-220F1, TN3: TO-252</p> <p>(3) G: Halogen Free and Lead Free, L: Lead Free</p>
---	---

■ MARKING

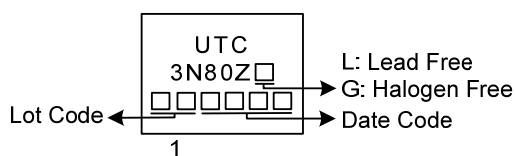

■ ABSOLUTE MAXIMUM RATINGS ( $T_C=25^\circ\text{C}$ , unless otherwise specified)

PARAMETER	SYMBOL	RATINGS	UNIT
Drain-Source Voltage ( $V_{GS}=0V$ )	$V_{DSS}$	800	V
Gate-Source Voltage	$V_{GSS}$	$\pm 20$	V
Minimum Gate-Source Breakdown Voltage ( $I_{GS}=\pm 1\text{mA}$ )	$BV_{GSO}$	30	V
Continuous Drain Current	$I_D$	3.0	A
Pulsed Drain Current	$I_{DM}$	12	A
Avalanche Current (Note 2)	$I_{AR}$	4.0	A
Single Pulse Avalanche Energy (Note 3)	$E_{AS}$	150	mJ
Peak Diode Recovery $dv/dt$ (Note 4)	$dv/dt$	3.1	V/ns
Power Dissipation	TO-220F1	25	W
	TO-252	50	W
Junction Temperature	$T_J$	+150	$^\circ\text{C}$
Storage Temperature	$T_{STG}$	-55 ~ +150	$^\circ\text{C}$

Notes: 1. Absolute maximum ratings are those values beyond which the device could be permanently damaged.

Absolute maximum ratings are stress ratings only and functional device operation is not implied.

2. Repetitive Rating: Pulse width limited by maximum junction temperature.

3.  $L=35\text{mH}$ ,  $I_{AS}=3.0\text{A}$ ,  $V_{DD}=50\text{V}$ ,  $R_G=25\ \Omega$ , Starting  $T_J = 25^\circ\text{C}$ .

4.  $I_{SD}\leq 3.0\text{A}$ ,  $di/dt\leq 200\text{A}/\mu\text{s}$ ,  $V_{DD}\leq BV_{DSS}$ , Starting  $T_J = 25^\circ\text{C}$

■ THERMAL DATA

PARAMETER		SYMBOL	RATING	UNIT
Junction to Ambient	TO-220F1	$\theta_{JA}$	62.5	$^\circ\text{C}/\text{W}$
	TO-252		110	$^\circ\text{C}/\text{W}$
Junction to Case	TO-220F1	$\theta_{JC}$	5.0	$^\circ\text{C}/\text{W}$
	TO-252		2.5	$^\circ\text{C}/\text{W}$

■ ELECTRICAL CHARACTERISTICS ( $T_J = 25^\circ\text{C}$ , unless otherwise specified)

PARAMETER	SYMBOL	TEST CONDITIONS	MIN	TYP	MAX	UNIT
<b>OFF CHARACTERISTICS</b>						
Drain-Source Breakdown Voltage	$BV_{DSS}$	$V_{GS}=0V, I_D=250\mu A$	800			V
Drain-Source Leakage Current	$I_{DSS}$	$V_{DS}=800V, V_{GS}=0V$			1	$\mu A$
Gate-Source Leakage Current	$I_{GSS}$	$V_{GS}=\pm 20V, V_{DS}=0V$			$\pm 10$	$\mu A$
<b>ON CHARACTERISTICS</b>						
Gate Threshold Voltage	$V_{GS(TH)}$	$V_{DS}=V_{GS}, I_D=250\mu A$	3.0		4.5	V
Static Drain-Source On-State Resistance	$R_{DS(ON)}$	$V_{GS}=10V, I_D=1.5A$			4.2	$\Omega$
<b>DYNAMIC CHARACTERISTICS</b>						
Input Capacitance	$C_{ISS}$	$V_{GS}=0V, V_{DS}=25V, f=1MHz$		625		pF
Output Capacitance	$C_{OSS}$			63		pF
Reverse Transfer Capacitance	$C_{RSS}$			9		pF
<b>SWITCHING CHARACTERISTICS</b>						
Total Gate Charge	$Q_G$	$V_{DS}=100V, V_{GS}=10V, I_D=3.0A, I_G=1mA$ (Note 1, 2)		18.5		nC
Gate to Source Charge	$Q_{GS}$			5.4		nC
Gate to Drain Charge	$Q_{GD}$			5.7		nC
Turn-ON Delay Time	$t_{D(ON)}$	$V_{DD}=100V, V_{GS}=10V, I_D=3.0A, R_G=25\Omega$ (Note 1, 2)		11.2		ns
Rise Time	$t_R$			20.2		ns
Turn-OFF Delay Time	$t_{D(OFF)}$			64		ns
Fall-Time	$t_F$			42.2		ns
<b>SOURCE- DRAIN DIODE RATINGS AND CHARACTERISTICS</b>						
Maximum Body-Diode Continuous Current	$I_{SD}$				3.0	A
Maximum Body-Diode Pulsed Current	$I_{SDM}$				12	A
Drain-Source Diode Forward Voltage	$V_{SD}$	$I_S=3.0A, V_{GS}=0V$			1.6	V
Reverse Recovery Time	$t_{rr}$	$I_S=3.0A, V_{GS}=0V,$		380		ns
Reverse Recovery Charge	$Q_{rr}$	$di_F/dt=100A/\mu s$		3.48		$\mu C$

Notes: 1. Pulse width=300 $\mu s$ , Duty cycle  $\leq 1.5\%$

2.  $C_{OSS(EQ)}$  is defined as constant equivalent capacitance giving the same charging time as  $C_{OSS}$  when  $V_{DS}$  increases from 0 to 80%  $V_{DSS}$ .

■ TEST CIRCUITS AND WAVEFORMS

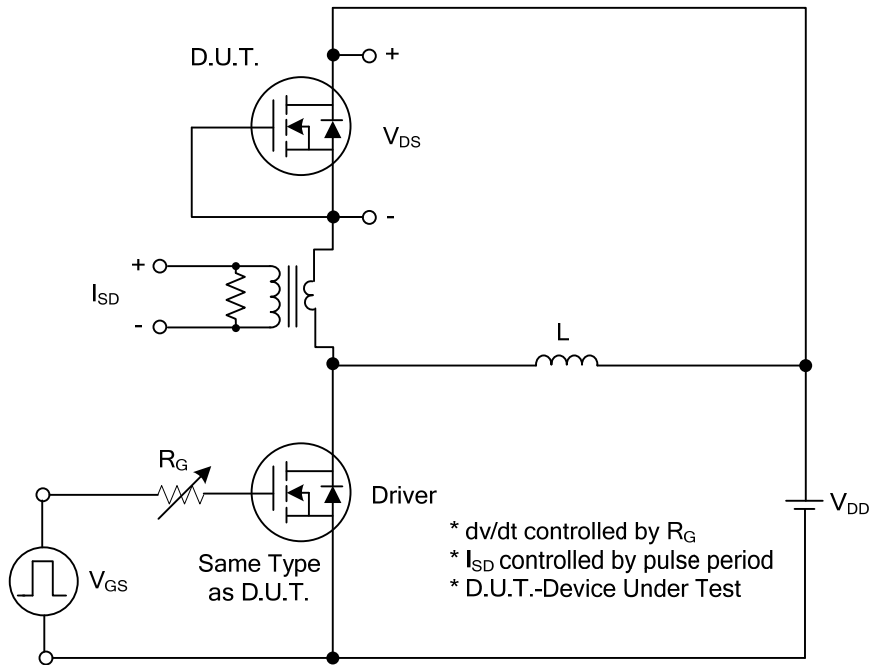

Peak Diode Recovery dv/dt Test Circuit

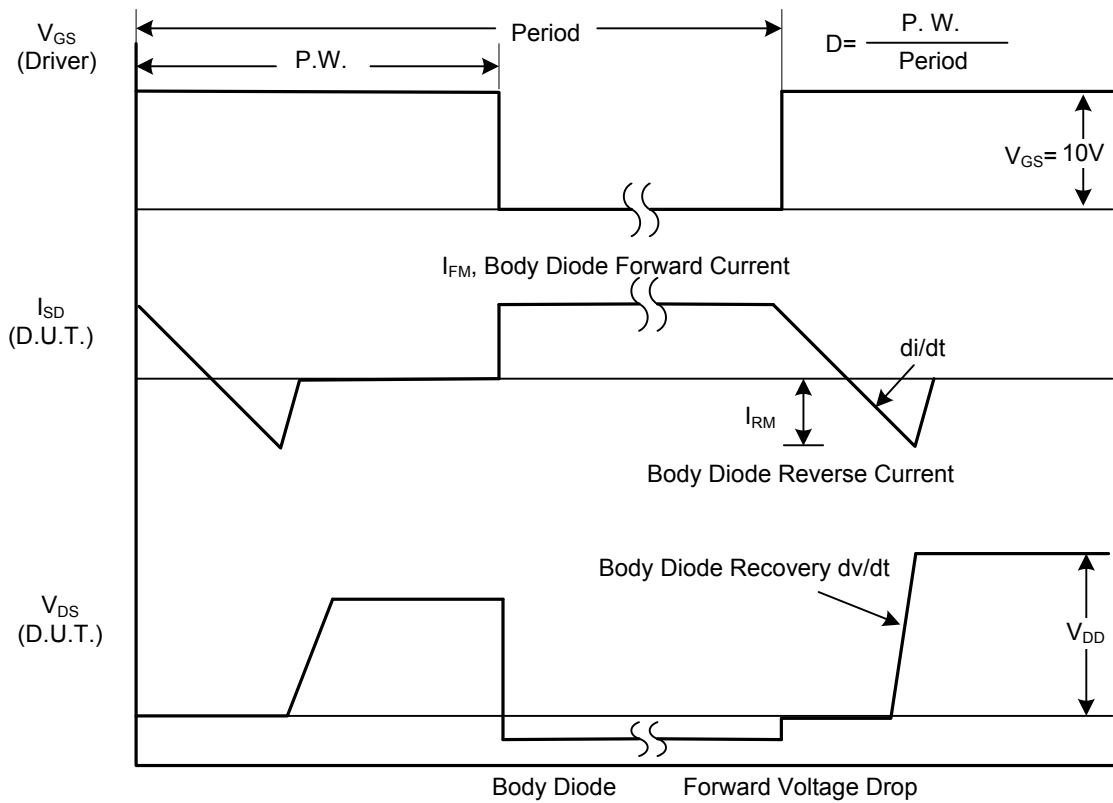

Peak Diode Recovery dv/dt Waveforms

■ TEST CIRCUITS AND WAVEFORMS (Cont.)

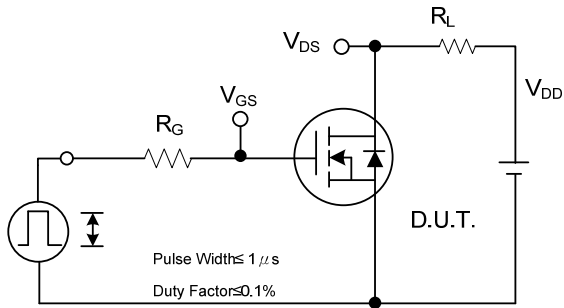

Switching Test Circuit

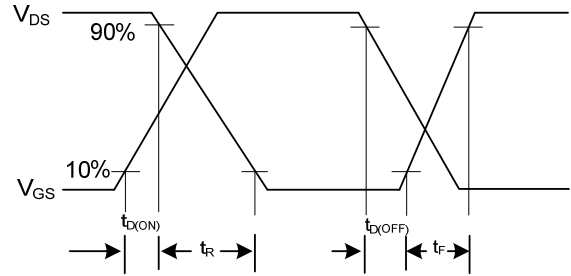

Switching Waveforms

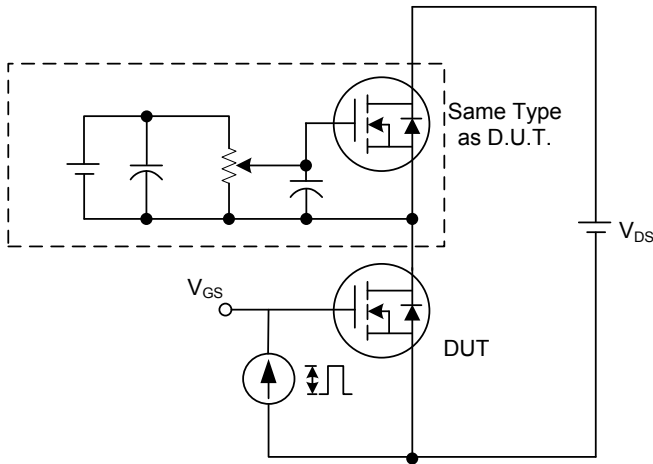

Gate Charge Test Circuit

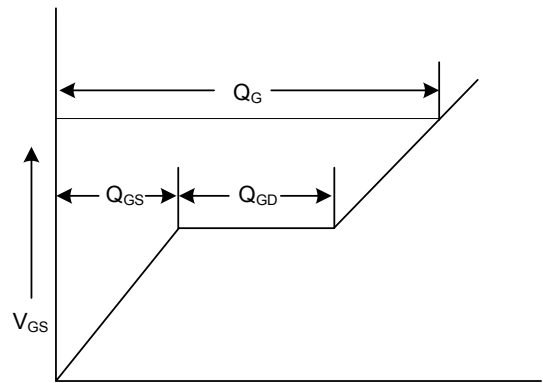

Charge  
Gate Charge Waveform

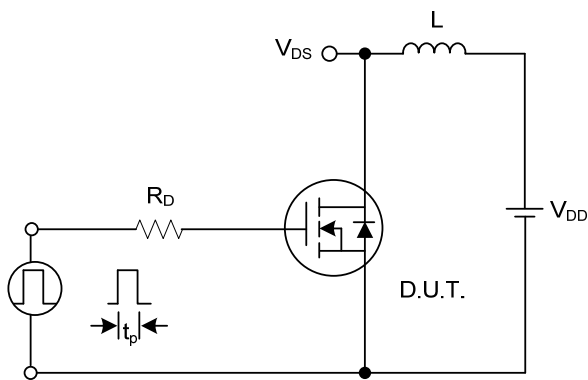

Unclamped Inductive Switching Test Circuit

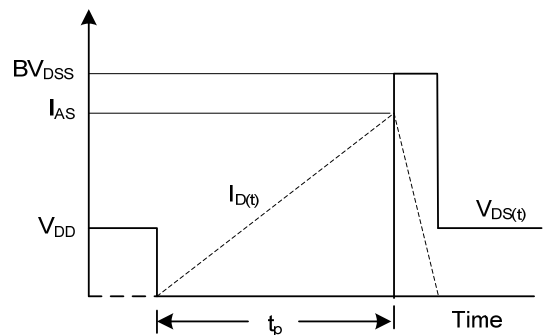

Unclamped Inductive Switching Waveforms

■ TYPICAL CHARACTERISTICS

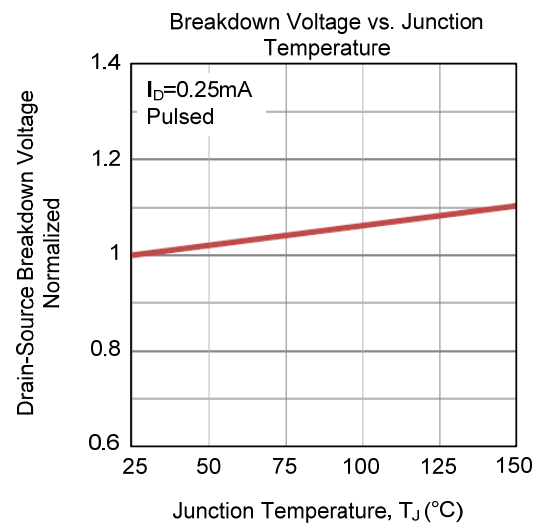
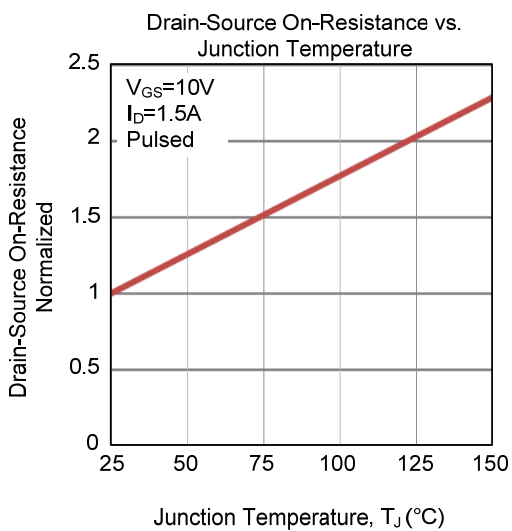
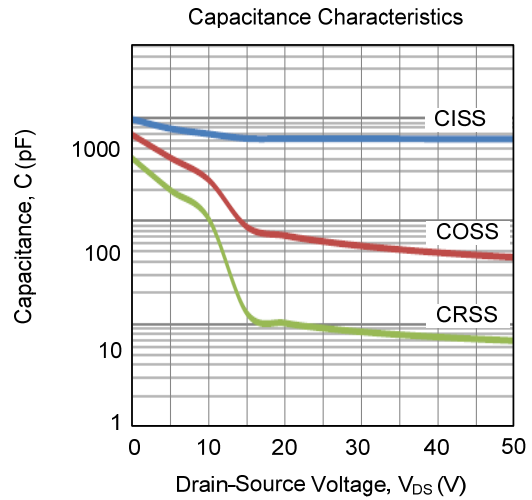
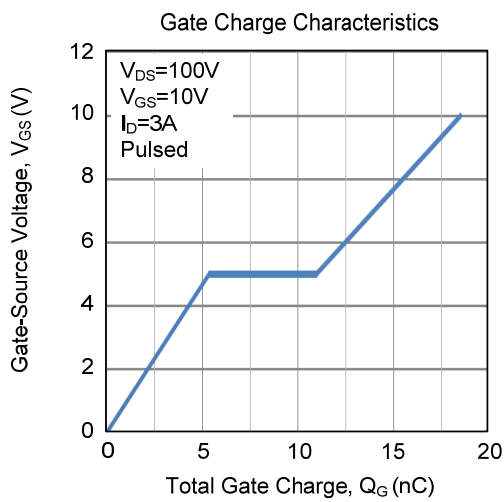
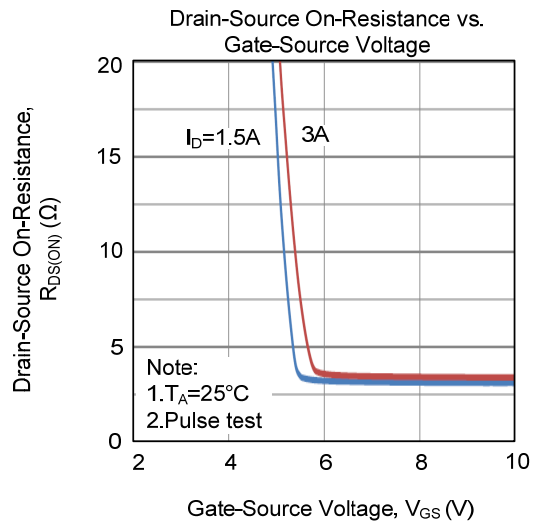
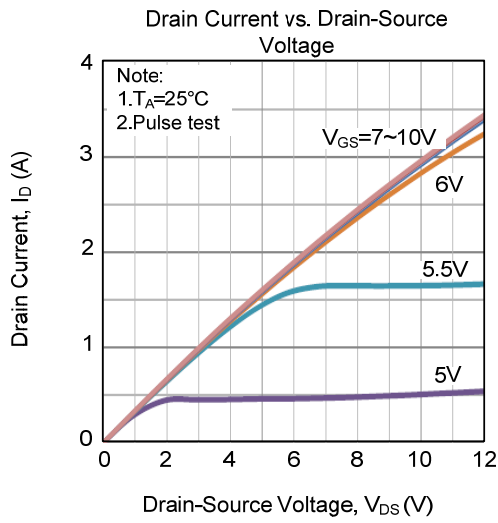

■ TYPICAL CHARACTERISTICS (Cont.)

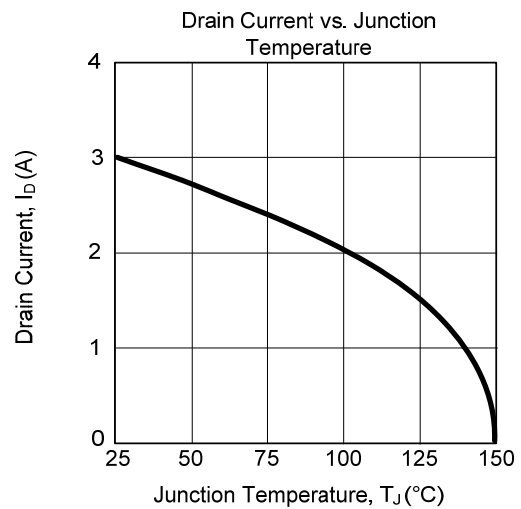
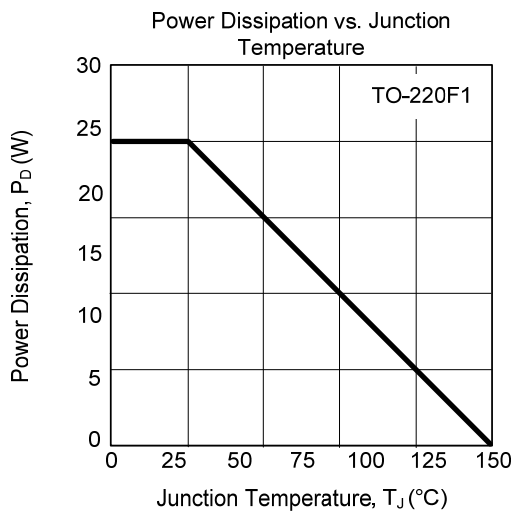
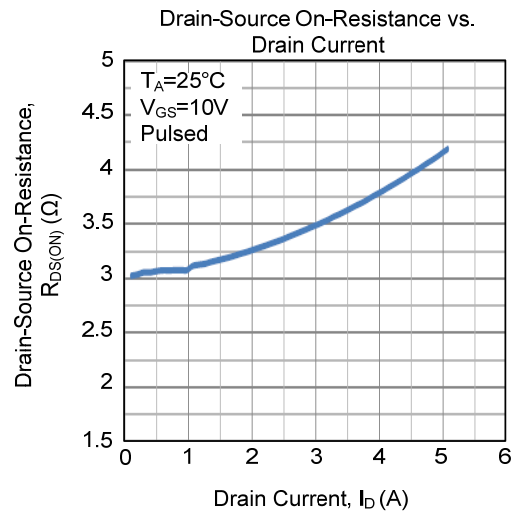
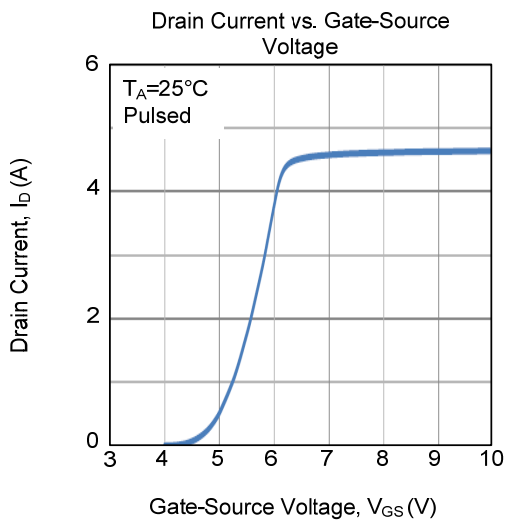
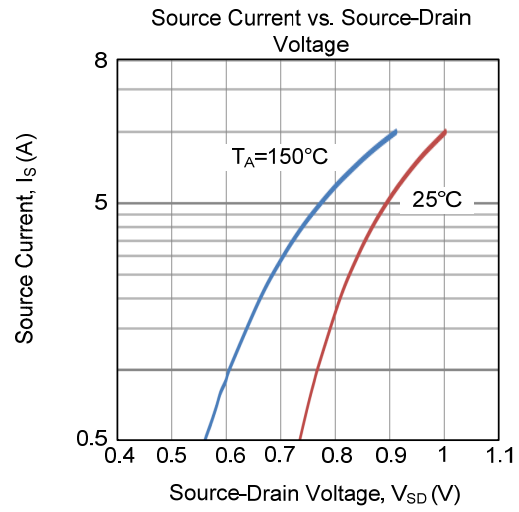
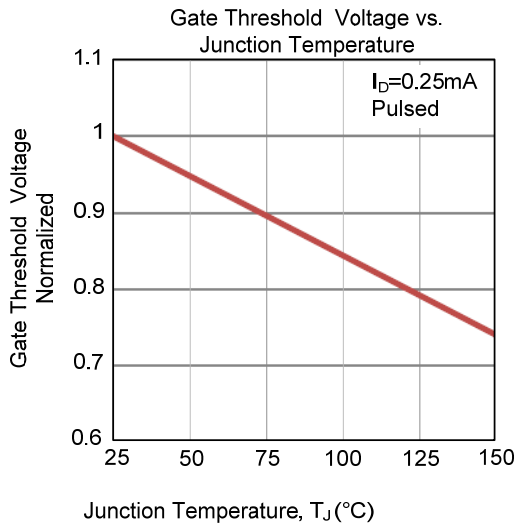

■ TYPICAL CHARACTERISTICS (Cont.)

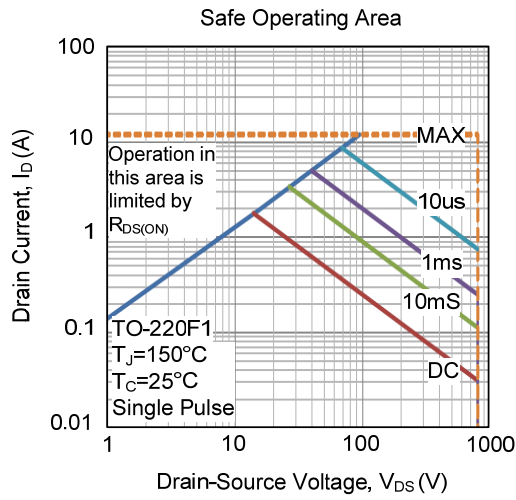

UTC assumes no responsibility for equipment failures that result from using products at values that exceed, even momentarily, rated values (such as maximum ratings, operating condition ranges, or other parameters) listed in products specifications of any and all UTC products described or contained herein. UTC products are not designed for use in life support appliances, devices or systems where malfunction of these products can be reasonably expected to result in personal injury. Reproduction in whole or in part is prohibited without the prior written consent of the copyright owner. UTC reserves the right to make changes to information published in this document, including without limitation specifications and product descriptions, at any time and without notice. This document supersedes and replaces all information supplied prior to the publication hereof.