



UF3N30Z

Power MOSFET

3A, 300V N-CHANNEL POWER MOSFET

■ DESCRIPTION

The UTC **UF3N30Z** is an N-channel enhancement mode Power MOSFET using UTC' s advanced technology to provide customers with a minimum on-state resistance, low gate charge and superior switching performance.

■ FEATURES

- * $R_{DS(ON)} < 2\Omega @ V_{GS}=10V, I_D=1.5A$
- * High switching speed
- * Typically 4nC low gate charge
- * 100% avalanche tested

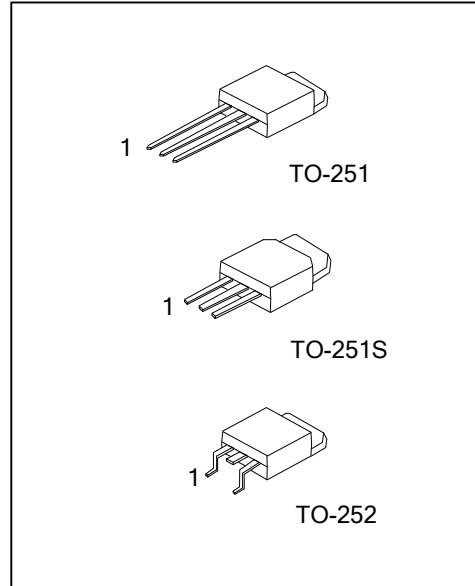

■ SYMBOL

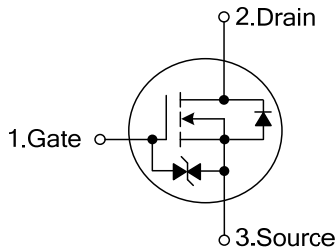

■ ORDERING INFORMATION

Ordering Number		Package	Pin Assignment			Packing
Lead Free	Halogen Free		1	2	3	
UF3N30ZL-TM3-T	UF3N30ZG-TM3-T	TO-251	G	D	S	Tube
UF3N30ZL-TMS-T	UF3N30ZG-TMS-T	TO-251S	G	D	S	Tube
UF3N30ZL-TN3-R	UF3N30ZG-TN3-R	TO-252	G	D	S	Tape Reel

Note: Pin Assignment: G: Gate D: Drain S: Source

<p>UF3N30ZL-TM3-T</p> <p>(1)Packing Type</p> <p>(2)Package Type</p> <p>(3)Green Package</p>	<p>(1) T: Tube, R: Tape Reel</p> <p>(2) TM3: TO-251, TMS: TO-251S, TN3: TO-252</p> <p>(3) L: Lead Free, G: Halogen Free and Lead Free</p>
---	---

■ MARKING

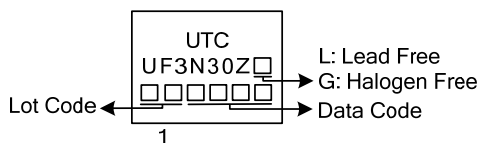

■ ABSOLUTE MAXIMUM RATINGS

PARAMETER		SYMBOL	RATINGS	UNIT
Drain-Source Voltage		V_{DSS}	300	V
Gate-Source Voltage		V_{GSS}	± 20	V
Continuous Drain Current	Continuous	I_D	3	A
	Pulsed	I_{DM}	12	A
Avalanche Energy		E_{AS}	52	mJ
Power Dissipation ($T_C=25^\circ\text{C}$)		P_D	50	W
Junction Temperature		T_J	+150	$^\circ\text{C}$
Storage Temperature Range		T_{STG}	-55~+150	$^\circ\text{C}$

Note Absolute maximum ratings are those values beyond which the device could be permanently damaged. Absolute maximum ratings are stress ratings only and functional device operation is not implied.

■ ELECTRICAL CHARACTERISTICS

PARAMETER		SYMBOL	TEST CONDITIONS	MIN	TYP	MAX	UNIT	
OFF CHARACTERISTICS								
Drain-Source Breakdown Voltage		BV_{DSS}	$I_D=250\mu\text{A}, V_{GS}=0\text{V}$	300			V	
Drain-Source Leakage Current		I_{DSS}	$V_{DS}=300\text{V}$			1	μA	
Gate-Source Leakage Current	Forward	I_{GSS}	$V_{GS}=+20\text{V}, V_{DS}=0\text{V}$			10	μA	
	Reverse		$V_{GS}=-20\text{V}, V_{DS}=0\text{V}$			-10	μA	
ON CHARACTERISTICS								
Gate Threshold Voltage		$V_{GS(TH)}$	$I_D=250\mu\text{A}$	2		4	V	
Static Drain-Source On-State Resistance		$R_{DS(ON)}$	$V_{GS}=10\text{V}, I_D=1.5\text{A}$			2	Ω	
DYNAMIC PARAMETERS								
Input Capacitance		C_{ISS}	$V_{GS}=0\text{V}, V_{DS}=25\text{V}, f=1\text{MHz}$		200		pF	
Output Capacitance		C_{OSS}				90		pF
Reverse Transfer Capacitance		C_{RSS}				30		pF
SWITCHING PARAMETERS								
Turn-ON Delay Time		$t_{D(ON)}$	$V_{DD}=30\text{V}, I_D=0.5\text{A}, R_G=25\Omega,$ $V_{GS}=0\sim 10\text{V}$		10		ns	
Rise Time		t_R				50		ns
Turn-OFF Delay Time		$t_{D(OFF)}$				30		ns
Fall-Time		t_F				40		ns
Total Gate Charge		Q_G	$V_{DD}=50\text{V}, I_D=1.3\text{A}, I_G=100\mu\text{A},$ $V_{GS}=10\text{V}$		4		nC	
Gate to Source Charge		Q_{GS}				0.64		nC
Gate to Drain Charge		Q_{GD}				1.6		nC
SOURCE- DRAIN DIODE RATINGS AND CHARACTERISTICS								
Maximum Body-Diode Continuous Current		I_S				3	A	
Maximum Body-Diode Pulsed Current		I_{SM}				12	A	
Drain-Source Diode Forward Voltage		V_{SD}	$I_S=0.85\text{A}$			1.3	V	

■ TYPICAL CHARACTERISTICS

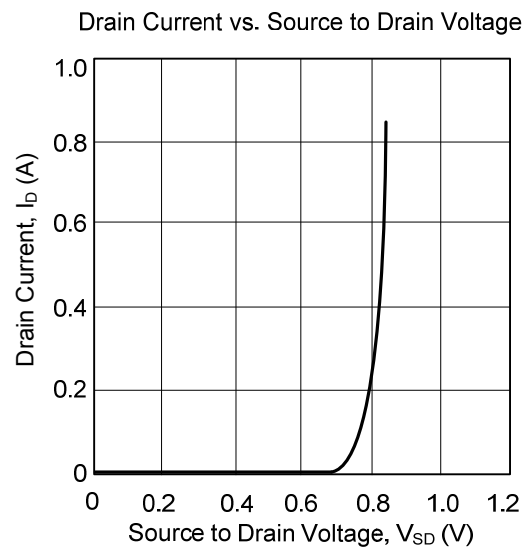
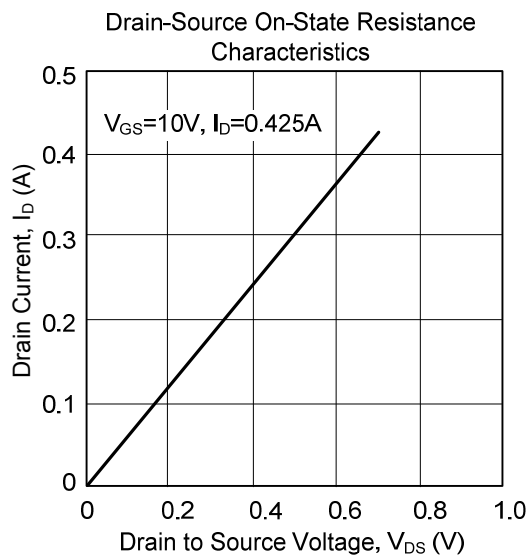
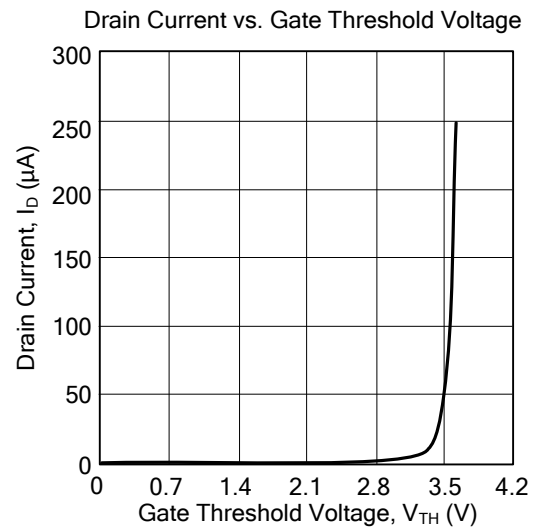
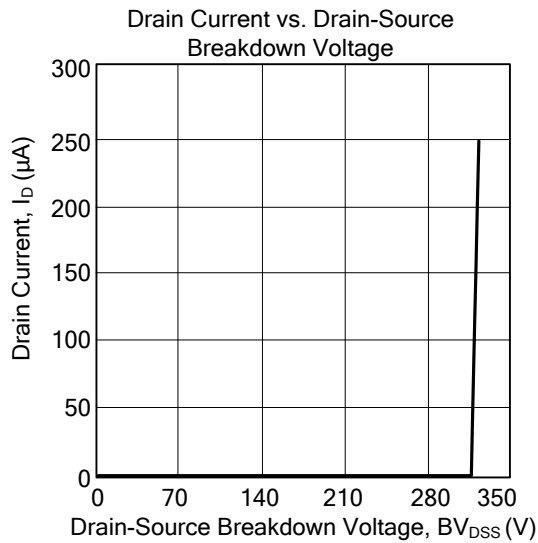

UTC assumes no responsibility for equipment failures that result from using products at values that exceed, even momentarily, rated values (such as maximum ratings, operating condition ranges, or other parameters) listed in products specifications of any and all UTC products described or contained herein. UTC products are not designed for use in life support appliances, devices or systems where malfunction of these products can be reasonably expected to result in personal injury. Reproduction in whole or in part is prohibited without the prior written consent of the copyright owner. The information presented in this document does not form part of any quotation or contract, is believed to be accurate and reliable and may be changed without notice.