



30N20

Power MOSFET

30A, 200V N-CHANNEL POWER MOSFET

■ DESCRIPTION

The UTC **30N20** is an N-channel mode Power FET, it uses UTC's advanced technology. This technology allows a minimum on-state resistance, superior switching performance. It also can withstand high energy pulse in the avalanche and commutation mode.

■ FEATURES

- * $R_{DS(ON)} < 75m\Omega @ V_{GS}=10V, I_D=15A$
- * Low Gate Charge (Typical 60nC)
- * High Switching Speed

■ SYMBOL

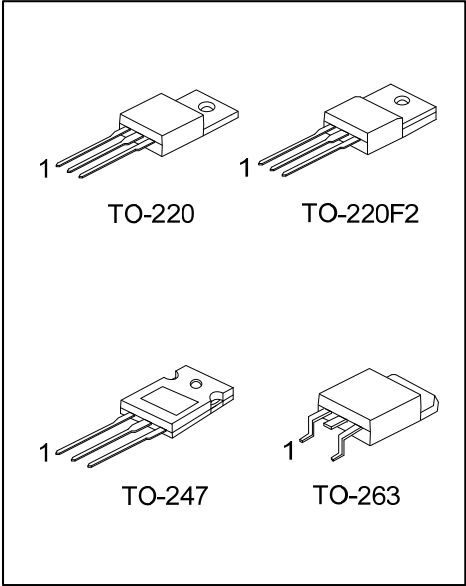
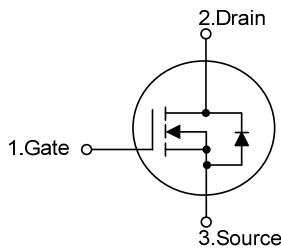

■ ORDERING INFORMATION

Ordering Number		Package	Pin Assignment			Packing
Lead Free	Halogen Free		1	2	3	
30N20L-TA3-T	30N20G-TF2-T	TO-220	G	D	S	Tube
30N20L-TF2-T	30N20G-TF2-T	TO-220F2	G	D	S	Tube
30N20L-T47-T	30N20G-T47-T	TO-247	G	D	S	Tube
30N20L-TQ2-T	30N20G-TQ2-T	TO-263	G	D	S	Tube
30N20L-TQ2-R	30N20G-TQ2-R	TO-263	G	D	S	Tape Reel

Note: Pin Assignment: G: Gate D: Drain S: Source

<p>30N20G-TF2-T</p> <p>(1)Packing Type</p> <p>(2)Package Type</p> <p>(3)Green Package</p>	<p>(1) T: Tube</p> <p>(2) TA3: TO-220, TF2: TO-220F2, T47: TO-247 TQ2: TO-263</p> <p>(3) G: Halogen Free and Lead Free, L: Lead Free</p>
---	--

■ MARKING

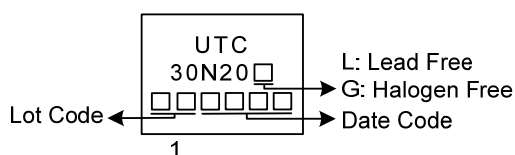

■ ABSOLUTE MAXIMUM RATINGS

PARAMETER		SYMBOL	RATINGS	UNIT
Drain-Source Voltage		V_{DSS}	200	V
Gate-Source Voltage		V_{GSS}	± 30	V
Drain Current	Continuous	I_D	30	A
	Pulsed	I_{DM}	90	A
Avalanche Energy		E_{AS}	640	mJ
Power Dissipation	TO-220/TO-263	P_D	140	W
	TO-220F2		40	W
	TO-247		214	W
Junction Temperature		T_J	+150	$^{\circ}\text{C}$
Storage Temperature Range		T_{STG}	-55 ~ +150	$^{\circ}\text{C}$

Note: Absolute maximum ratings are those values beyond which the device could be permanently damaged. Absolute maximum ratings are stress ratings only and functional device operation is not implied.

■ THERMAL DATA

PARAMETER		SYMBOL	RATINGS	UNIT
Junction to Ambient	TO-220/TO-220F2	θ_{JA}	62.5	$^{\circ}\text{C/W}$
	TO-263			
	TO-247			
Junction to Case	TO-220/TO-263	θ_{JC}	0.89	$^{\circ}\text{C/W}$
	TO-220F2		3.125	$^{\circ}\text{C/W}$
	TO-247		0.58	$^{\circ}\text{C/W}$

■ ELECTRICAL CHARACTERISTICS

PARAMETER		SYMBOL	TEST CONDITIONS	MIN	TYP	MAX	UNIT
OFF CHARACTERISTICS							
Drain-Source Breakdown Voltage		BV_{DSS}	$I_D=250\mu\text{A}, V_{GS}=0\text{V}$	200			V
Drain-Source Leakage Current		I_{DSS}	$V_{DS}=200\text{V}$			1	μA
Gate-Source Leakage Current	Forward	I_{GSS}	$V_{GS}=+30\text{V}, V_{DS}=0\text{V}$			+100	nA
	Reverse		$V_{GS}=-30\text{V}, V_{DS}=0\text{V}$			-100	nA
ON CHARACTERISTICS							
Gate Threshold Voltage		$V_{GS(TH)}$	$I_D=250\mu\text{A}$	1.5		3.5	V
Static Drain-Source On-State Resistance		$R_{DS(ON)}$	$V_{GS}=10\text{V}, I_D=15\text{A}$			75	m Ω
DYNAMIC PARAMETERS							
Input Capacitance		C_{ISS}	$V_{GS}=0\text{V}, V_{DS}=25\text{V}, f=1\text{MHz}$		2400	3100	pF
Output Capacitance		C_{OSS}			430	560	pF
Reverse Transfer Capacitance		C_{RSS}			55	70	pF
SWITCHING PARAMETERS							
Total Gate Charge		Q_G	$V_{DD}=50\text{V}, V_{GS}=10\text{V}, I_D=1.3\text{A}$		60	78	nC
Gate to Source Charge		Q_{GS}			17		nC
Gate to Drain Charge		Q_{GD}			27		nC
Turn-ON Delay Time		$t_{D(ON)}$	$V_{DD}=30\text{V}, I_D=0.5\text{A}, R_G=25\Omega, V_{GS}=0\sim 10\text{V}$		40		ns
Rise Time		t_R			280		ns
Turn-OFF Delay Time		$t_{D(OFF)}$			125		ns
Fall-Time		t_F			115		ns
SOURCE- DRAIN DIODE RATINGS AND CHARACTERISTICS							
Maximum Body-Diode Continuous Current		I_S				30	A
Maximum Body-Diode Pulsed Current		I_{SM}				90	A
Drain-Source Diode Forward Voltage		V_{SD}	$I_S=30\text{A}, V_{GS}=0\text{V}$			1.5	V

■ TEST CIRCUITS AND WAVEFORMS

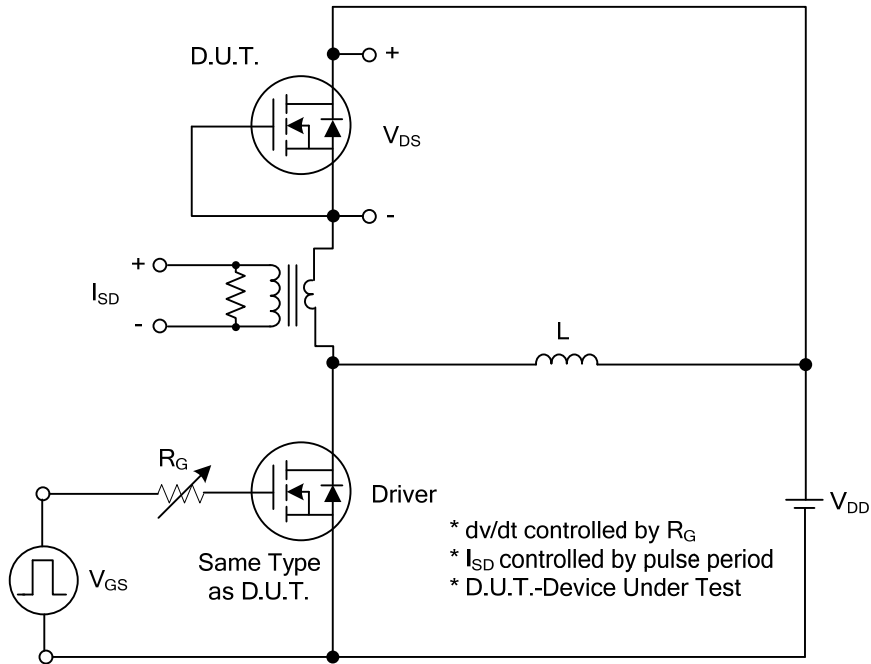

Peak Diode Recovery dv/dt Test Circuit

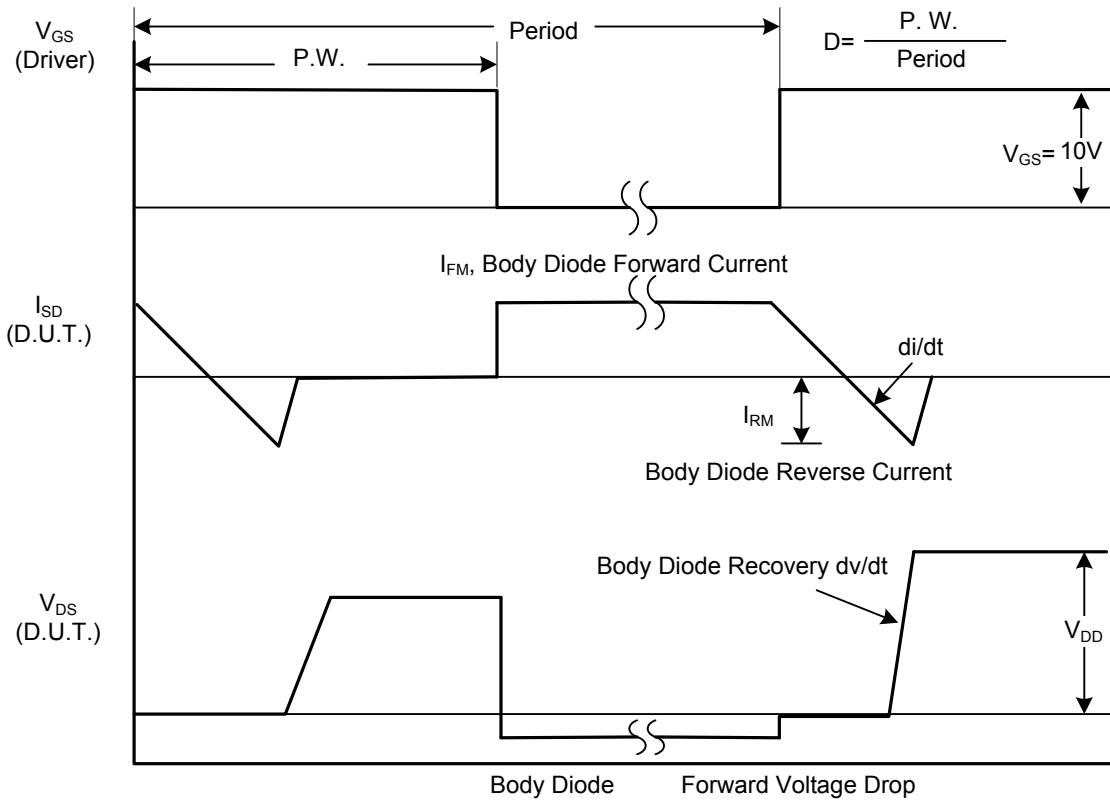

Peak Diode Recovery dv/dt Waveforms

TEST CIRCUITS AND WAVEFORMS

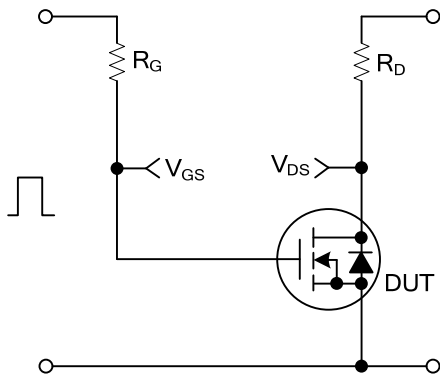

Switching Test Circuit

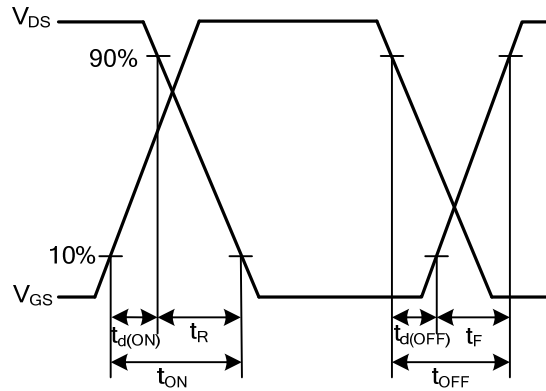

Switching Waveforms

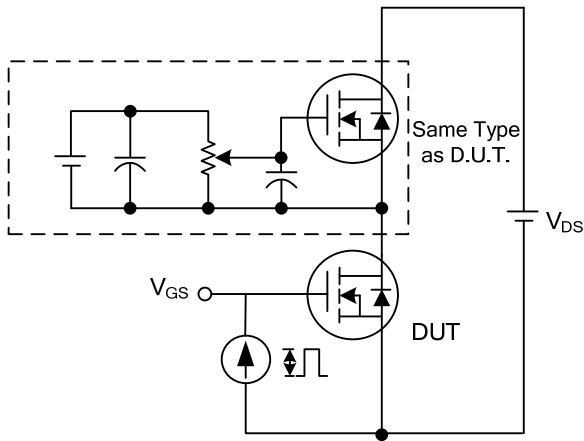

Gate Charge Test Circuit

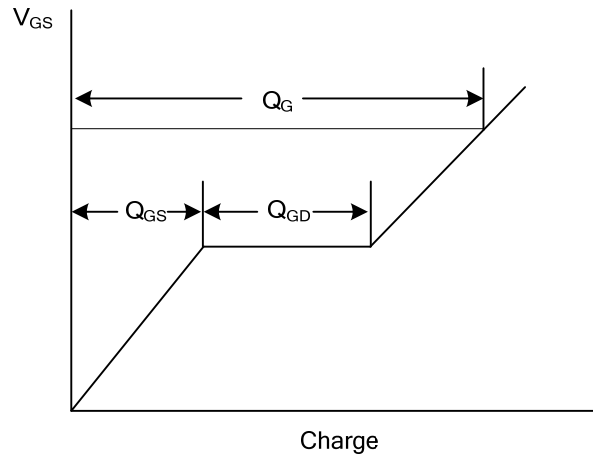

Gate Charge Waveform

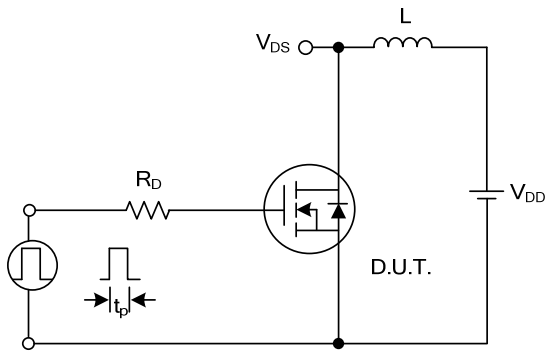

Unclamped Inductive Switching Test Circuit

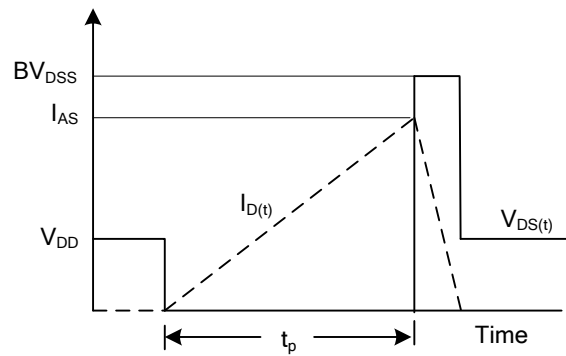

Unclamped Inductive Switching Waveforms

UTC assumes no responsibility for equipment failures that result from using products at values that exceed, even momentarily, rated values (such as maximum ratings, operating condition ranges, or other parameters) listed in products specifications of any and all UTC products described or contained herein. UTC products are not designed for use in life support appliances, devices or systems where malfunction of these products can be reasonably expected to result in personal injury. Reproduction in whole or in part is prohibited without the prior written consent of the copyright owner. UTC reserves the right to make changes to information published in this document, including without limitation specifications and product descriptions, at any time and without notice. This document supersedes and replaces all information supplied prior to the publication hereof.