



4N60K

Power MOSFET

4.0A, 600V N-CHANNEL POWER MOSFET

■ DESCRIPTION

The UTC **4N60K** is a high voltage power MOSFET and is designed to have better characteristics, such as fast switching time, low gate charge, low on-state resistance and have a high rugged avalanche characteristics. This power MOSFET is usually used at high speed switching applications in power supplies, PWM motor controls, high efficient DC to DC converters and bridge circuits.

■ FEATURES

- * $R_{DS(ON)} < 2.5\Omega @ V_{GS} = 10V$
- * Ultra Low Gate Charge (typical 15 nC)
- * Low Reverse Transfer CAPACITANCE ($C_{RSS} =$ typical 8.0 pF)
- * Fast Switching Capability
- * Avalanche Energy Specified
- * Improved dv/dt Capability, high Ruggedness

■ SYMBOL

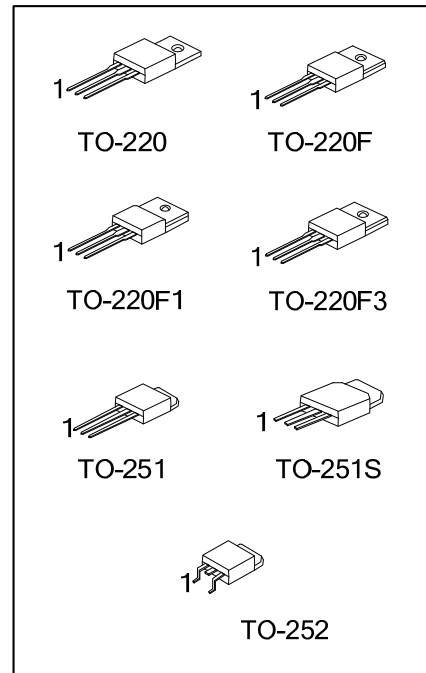
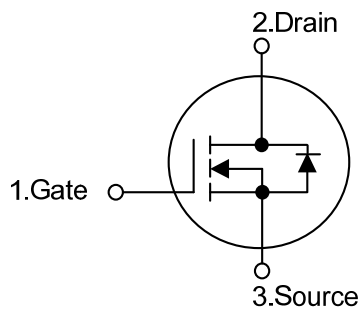

ORDERING INFORMATION

Ordering Number		Package	Pin Assignment			Packing
Lead Free	Halogen Free		1	2	3	
4N60KL-TA3-T	4N60KG-TA3-T	TO-220	G	D	S	Tube
4N60KL-TF3-T	4N60KG-TF3-T	TO-220F	G	D	S	Tube
4N60KL-TF1-T	4N60KG-TF1-T	TO-220F1	G	D	S	Tube
4N60KL-TF3T-T	4N60KG-TF3T-T	TO-220F3	G	D	S	Tube
4N60KL-TM3-T	4N60KG-TM3-T	TO-251	G	D	S	Tube
4N60KL-TMS-T	4N60KG-TMS-T	TO-251S	G	D	S	Tube
4N60KL-TN3-R	4N60KG-TN3-R	TO-252	G	D	S	Tape Reel

Note: Pin Assignment: G: Gate D: Drain S: Source

<p>4N60KL-TA3-T</p> <p>(1) Packing Type</p> <p>(2) Package Type</p> <p>(3) Green Package</p>	<p>(1) T: Tube, R: Tape Reel</p> <p>(2) TA3: TO-220, TF3: TO-220F, TF1: TO-220F1, TF3T: TO-220F3, TM3: TO-251, TMS: TO-251S, TN3: TO-252</p> <p>(3) L: Lead Free, G: Halogen Free and Lead Free</p>
--	---

MARKING

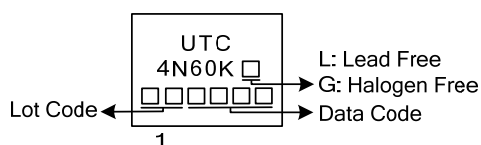

■ ABSOLUTE MAXIMUM RATINGS ($T_C = 25^\circ\text{C}$, unless otherwise specified)

PARAMETER		SYMBOL	RATINGS	UNIT
Drain-Source Voltage		V_{DSS}	600	V
Gate-Source Voltage		V_{GSS}	± 30	V
Avalanche Current (Note 2)		I_{AR}	4.4	A
Drain Current	Continuous	I_D	4.0	A
	Pulsed (Note 2)	I_{DM}	16	A
Avalanche Energy	Single Pulsed (Note 3)	E_{AS}	100	mJ
	Repetitive (Note 2)	E_{AR}	10.6	mJ
Peak Diode Recovery dv/dt (Note 4)		dv/dt	4.5	V/ns
Power Dissipation	TO-220	P_D	106	W
	TO-220F/TO-220F1		36	W
	TO-220F3			
	TO-251/TO-251S TO-252		50	W
Junction Temperature		T_J	+150	$^\circ\text{C}$
Operating Temperature		T_{OPR}	-55 ~ +150	$^\circ\text{C}$
Storage Temperature		T_{STG}	-55 ~ +150	$^\circ\text{C}$

Notes: 1. Absolute maximum ratings are those values beyond which the device could be permanently damaged.

Absolute maximum ratings are stress ratings only and functional device operation is not implied.

2. Repetitive Rating : Pulse width limited by maximum junction temperature

3. $L = 12.5\text{mH}$, $I_{AS} = 4\text{A}$, $V_{DD} = 50\text{V}$, $R_G = 25\ \Omega$, Starting $T_J = 25^\circ\text{C}$

4. $I_{SD} \leq 4.4\text{A}$, $di/dt \leq 200\text{A}/\mu\text{s}$, $V_{DD} \leq BV_{DSS}$, Starting $T_J = 25^\circ\text{C}$

■ THERMAL DATA

PARAMETER		SYMBOL	RATINGS	UNIT
Junction to Ambient	TO-220/TO-220F TO-220F1/TO-220F3	θ_{JA}	62.5	$^\circ\text{C}/\text{W}$
	TO-251/TO-251S TO-252		83	$^\circ\text{C}/\text{W}$
	TO-220		1.18	$^\circ\text{C}/\text{W}$
Junction to Case	TO-220F/TO-220F1 TO-220F3	θ_{Jc}	3.47	$^\circ\text{C}/\text{W}$
	TO-251/TO-251S TO-252		2.5	$^\circ\text{C}/\text{W}$

■ ELECTRICAL CHARACTERISTICS ($T_C=25^\circ\text{C}$, unless otherwise specified)

PARAMETER	SYMBOL	TEST CONDITIONS	MIN	TYP	MAX	UNIT
OFF CHARACTERISTICS						
Drain-Source Breakdown Voltage	BV_{DSS}	$V_{GS}=0V, I_D=250\mu A$	600			V
Drain-Source Leakage Current	I_{DSS}	$V_{DS}=600V, V_{GS}=0V$			10	μA
		$V_{DS}=600V, V_{GS}=0V, T_C=125^\circ\text{C}$			10	μA
Gate-Source Leakage Current	Forward	I_{GSS}				
	Reverse					
		$V_{GS}=30V, V_{DS}=0V$			100	nA
		$V_{GS}=-30V, V_{DS}=0V$			-100	nA
Breakdown Voltage Temperature Coefficient	$\Delta BV_{DSS}/\Delta T_J$	$I_D=250\mu A$, Referenced to 25°C		0.6		$V/^\circ\text{C}$
ON CHARACTERISTICS						
Gate Threshold Voltage	$V_{GS(TH)}$	$V_{DS}=V_{GS}, I_D=250\mu A$	3.0		5.0	V
Static Drain-Source On-State Resistance	$R_{DS(ON)}$	$V_{GS}=10V, I_D=2.2A$		2.2	2.5	Ω
DYNAMIC CHARACTERISTICS						
Input Capacitance	C_{ISS}	$V_{DS}=25V, V_{GS}=0V,$ $f=1\text{MHz}$		520	670	pF
Output Capacitance	C_{OSS}			70	90	pF
Reverse Transfer Capacitance	C_{RSS}			8	11	pF
SWITCHING CHARACTERISTICS						
Turn-On Delay Time	$t_{D(ON)}$	$V_{DD}=300V, I_D=4.0A,$ $R_G=25\Omega$ (Note 1, 2)		13	35	ns
Turn-On Rise Time	t_R			45	100	ns
Turn-Off Delay Time	$t_{D(OFF)}$			25	60	ns
Turn-Off Fall Time	t_F			35	80	ns
Total Gate Charge	Q_G	$V_{DS}=480V, I_D=4.0A,$ $V_{GS}=10V$ (Note 1, 2)		15	20	nC
Gate-Source Charge	Q_{GS}			3.4		nC
Gate-Drain Charge	Q_{GD}			7.1		nC
SOURCE- DRAIN DIODE RATINGS AND CHARACTERISTICS						
Maximum Continuous Drain-Source Diode Forward Current	I_S				4.0	A
Maximum Pulsed Drain-Source Diode Forward Current	I_{SM}				17.6	A
Drain-Source Diode Forward Voltage	V_{SD}	$V_{GS}=0V, I_S=4.0A$			1.4	V
Reverse Recovery Time	t_{rr}	$V_{GS}=0V, I_S=4.0A,$ $dI_F/dt=100A/\mu s$ (Note 1)		250		ns
Reverse Recovery Charge	Q_{rr}			1.5		μC

Notes: 1. Pulse Test: Pulse width $\leq 300\mu s$, Duty cycle $\leq 2\%$.

2. Essentially independent of operating temperature.

■ TEST CIRCUITS AND WAVEFORMS

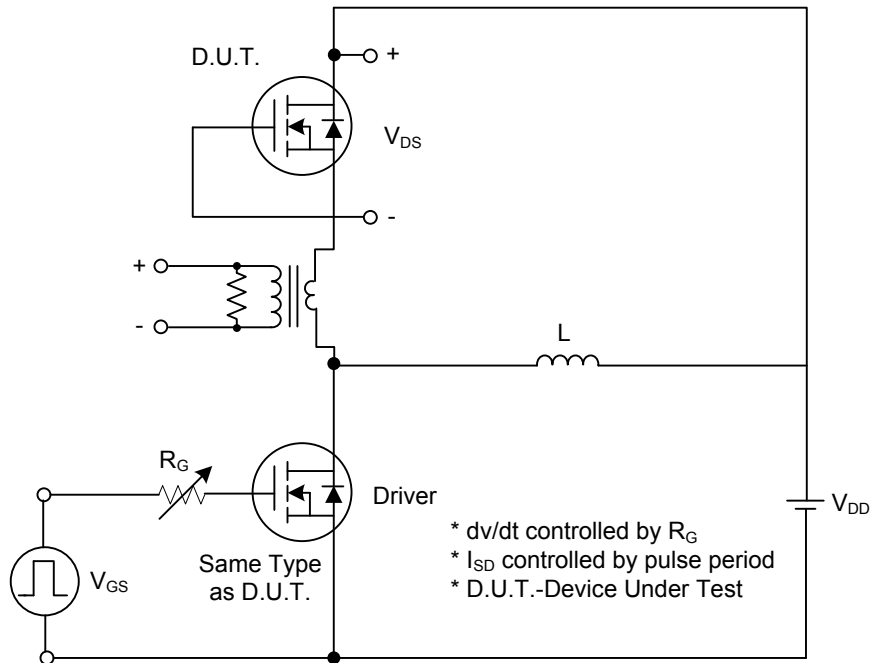

Peak Diode Recovery dv/dt Test Circuit

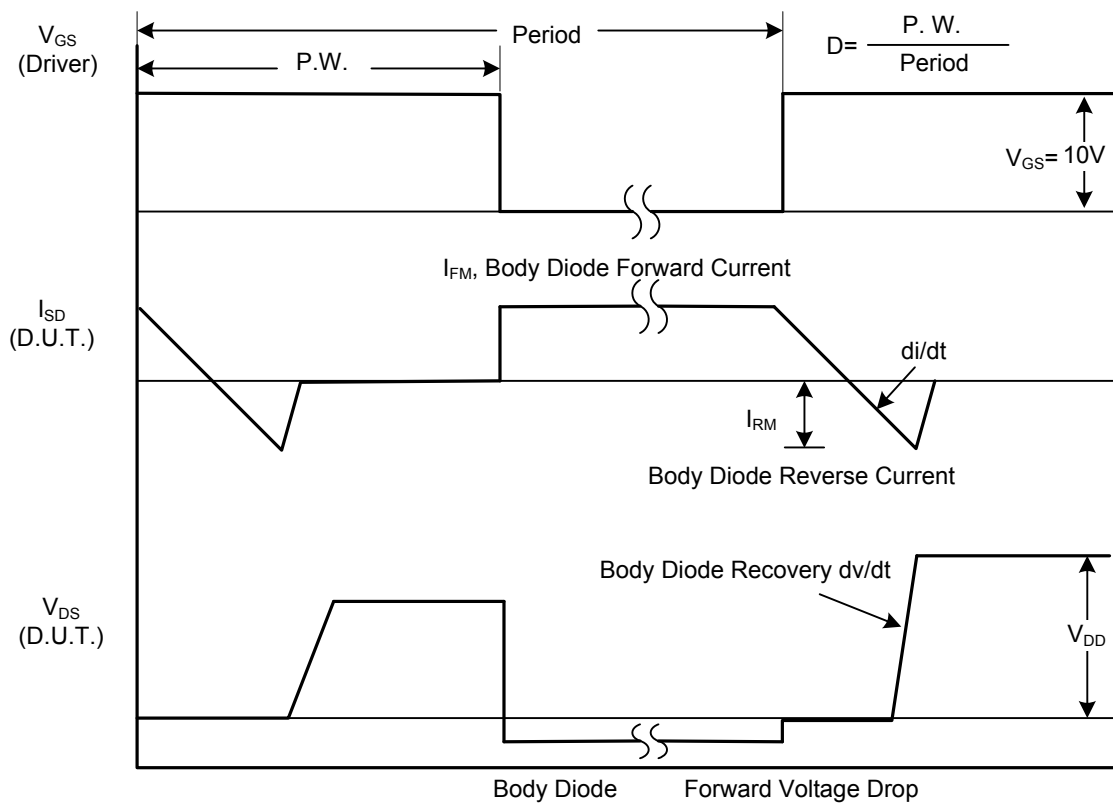

Peak Diode Recovery dv/dt Waveforms

■ TEST CIRCUITS AND WAVEFORMS (Cont.)

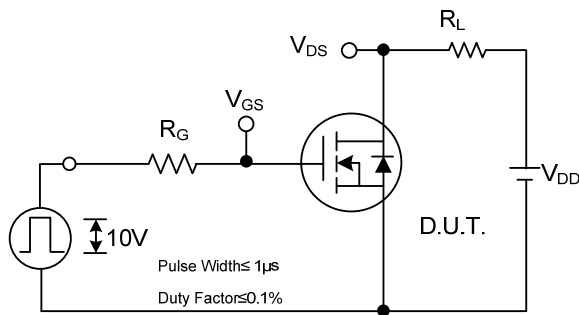

Switching Test Circuit

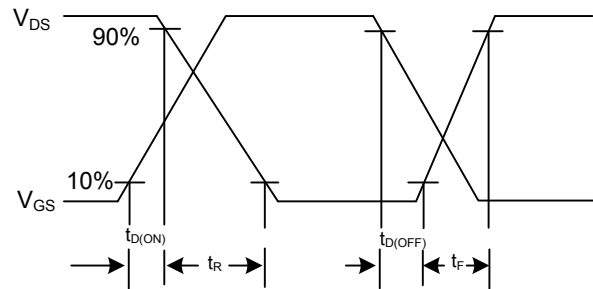

Switching Waveforms

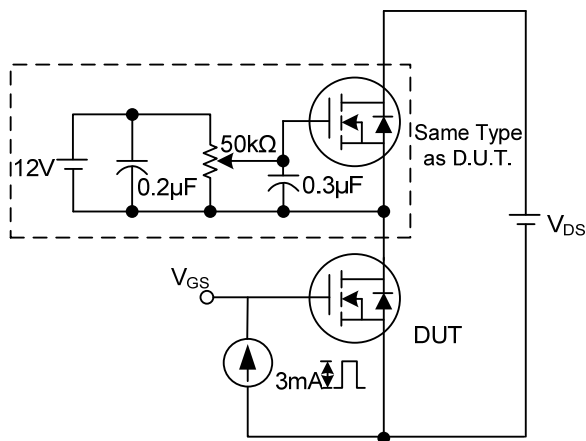

Gate Charge Test Circuit

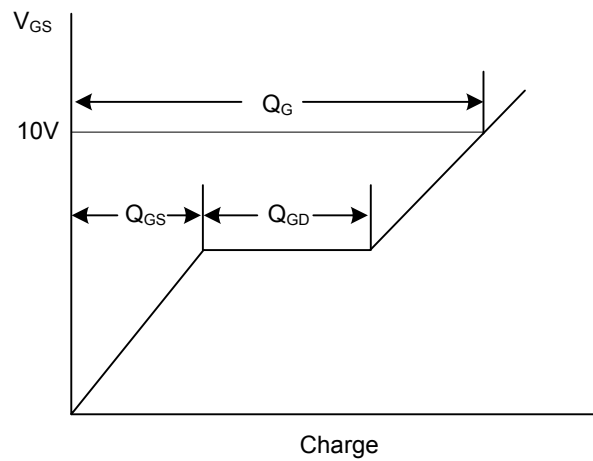

Gate Charge Waveform

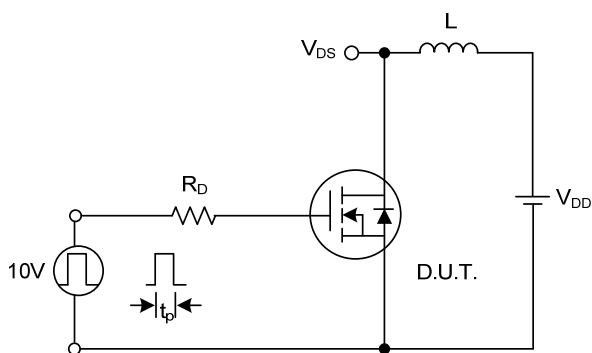

Unclamped Inductive Switching Test Circuit

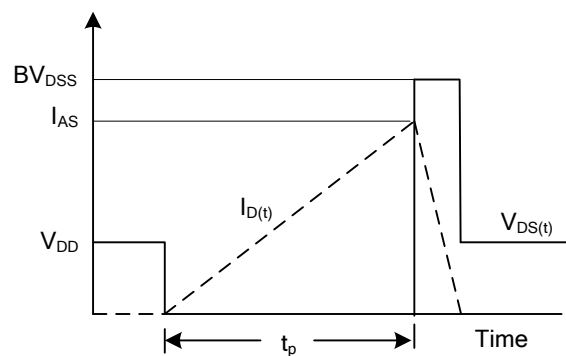

Unclamped Inductive Switching Waveforms

TYPICAL CHARACTERISTICS

Breakdown Voltage Variation vs. Temperature

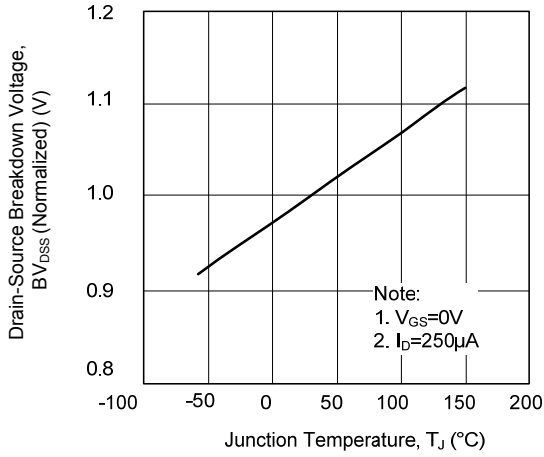

On-Resistance Junction Temperature

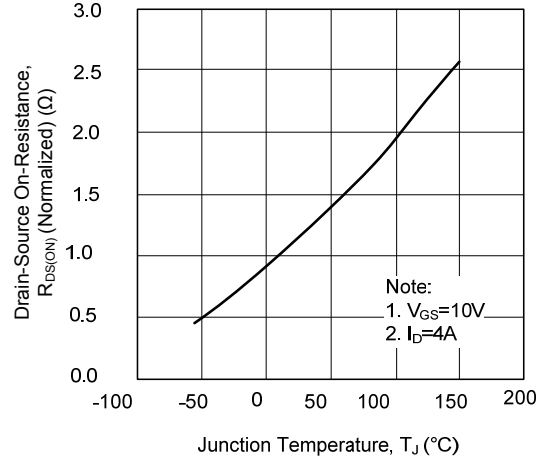

Safe Operating Area - 600V

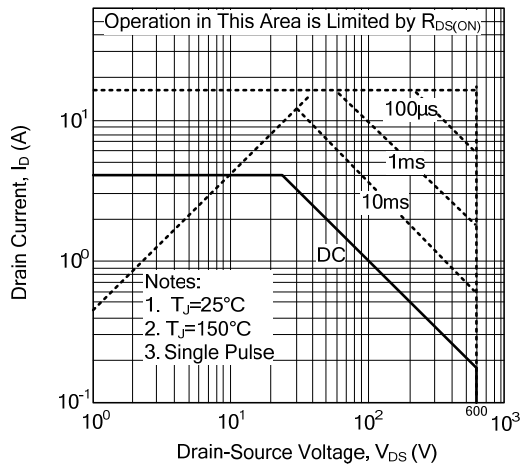

Maximum Drain Current vs. Case Temperature

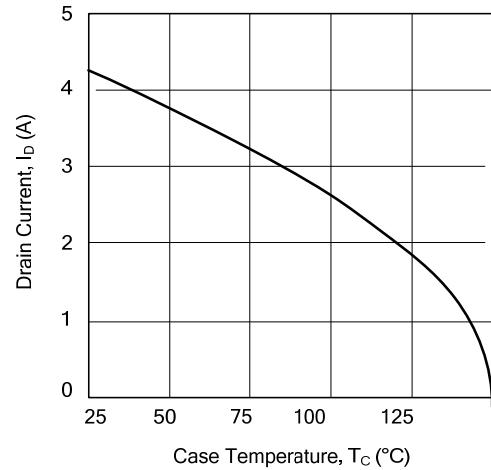

On-State Characteristics

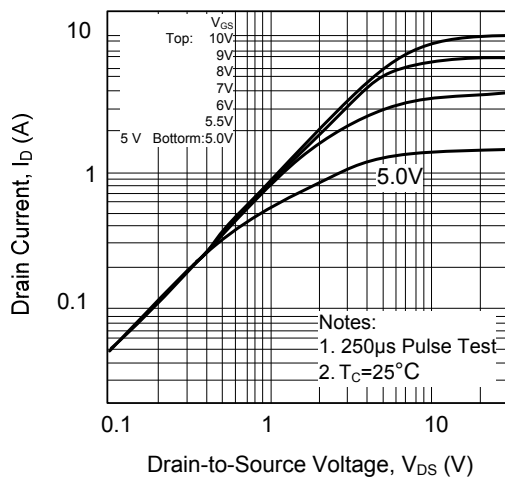

Transfer Characteristics

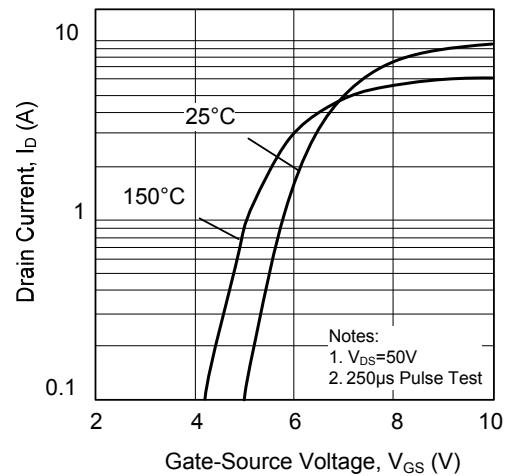

■ TYPICAL CHARACTERISTICS(Cont.)

On-Resistance Variation vs. Drain Current and Gate Voltage

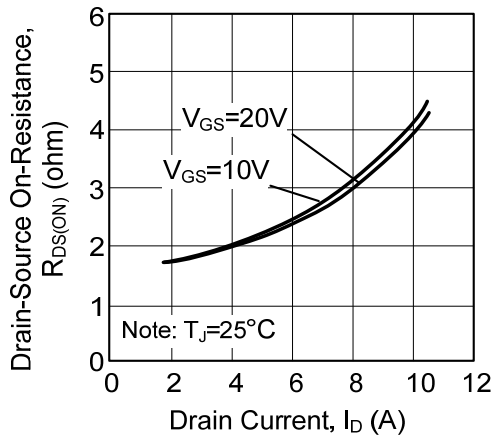

On State Current vs. Allowable Case Temperature

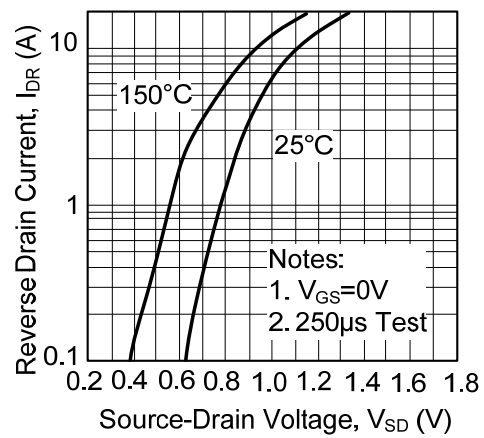

Capacitance Characteristics (Non-Repetitive)

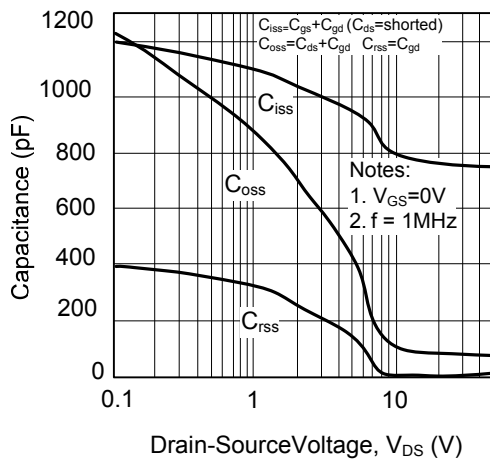

Gate Charge Characteristics

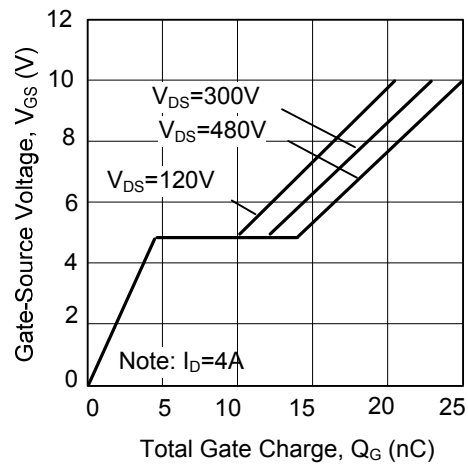

Transient Thermal Response Curve

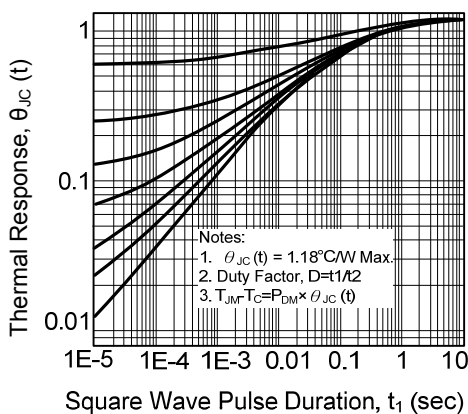

Power Dissipation

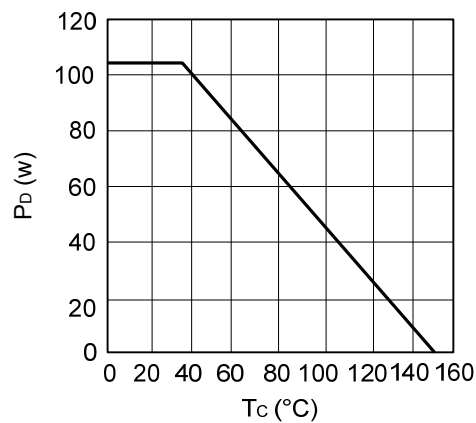

UTC assumes no responsibility for equipment failures that result from using products at values that exceed, even momentarily, rated values (such as maximum ratings, operating condition ranges, or other parameters) listed in products specifications of any and all UTC products described or contained herein. UTC products are not designed for use in life support appliances, devices or systems where malfunction of these products can be reasonably expected to result in personal injury. Reproduction in whole or in part is prohibited without the prior written consent of the copyright owner. The information presented in this document does not form part of any quotation or contract, is believed to be accurate and reliable and may be changed without notice.