



TC4069

CMOS IC

INVERTER CIRCUITS

DESCRIPTION

The UTC **TC4069** consists of six inverter circuits and is manufactured using complementary MOS (CMOS) to achieve wide power supply operating range, low power consumption, high noise immunity, symmetric controlled rise and fall times.

All inputs are protected from damage of static discharge by diode clamps to V_{DD} and V_{SS} .

FEATURES

- * Wide supply voltage range: 3.0V ~ 18V.
- * High noise immunity: 0.45 V_{DD} TYP.
- * Low Power TTL compatibility: Fan out of 2 driving 74L or 1 driving 74LS.

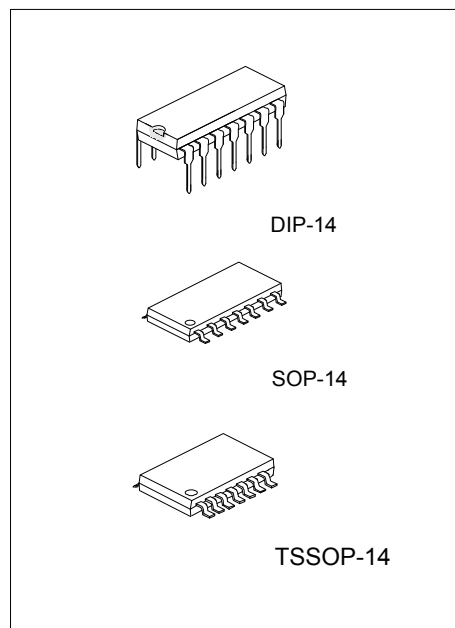

ORDERING INFORMATION

Ordering Number		Package	Packing
Lead Free	Halogen Free		
TC4069L-D14-T	TC4069G-D14-T	DIP-14	Tube
TC4069L-S14-R	TC4069G-S14-R	SOP-14	Tape Reel
TC4069L-P14-R	TC4069G-P14-R	TSSOP-14	Tape Reel

<p>TC4069G-D14-T</p> <p>(1) Packing Type</p> <p>(2) Package Type</p> <p>(3) Green Package</p>	<p>(1) T: Tube, R: Tape Reel</p> <p>(2) D14: DIP-14, S14: SOP-14, P14: TSSOP-14</p> <p>(3) G: Halogen Free and Lead Free, L: Lead Free</p>
---	--

MARKING

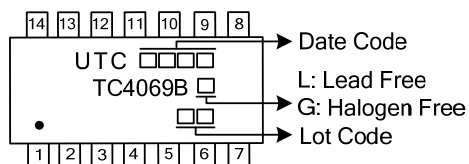

■ PIN CONFIGURATION

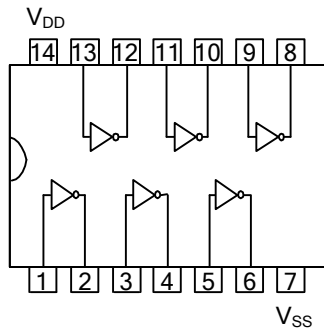

■ BLOCK DIAGRAM

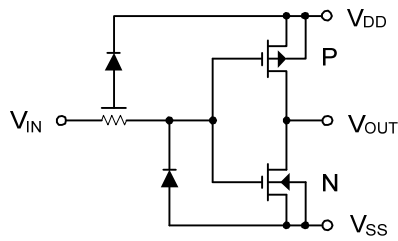

■ ABSOLUTE MAXIMUM RATINGS (Note 2, 3)

PARAMETER		SYMBOL	RATINGS	UNIT
DC Supply Voltage		V_{DD}	-0.5 ~ +20	V
Input Voltage		V_{IN}	-0.5 ~ $V_{DD} + 0.5$	V
Storage Temperature		T_S	-65 ~ +150	°C
Power Dissipation	DIP-14	P_D	300	mW
	SOP-14		180	
	TSSOP-14			
Junction Temperature		T_J	125	°C
Operating Temperature		T_{OPR}	-40 ~ +85	°C
Storage Temperature		T_{STG}	-65 ~ +150	°C

Notes: 1. Absolute maximum ratings are those values beyond which the device could be permanently damaged.

Absolute maximum ratings are stress ratings only and functional device operation is not implied.

2. AC Parameters are guaranteed by DC correlated testing.

3. I_{OH} and I_{OL} are tested one output at a time.

■ RECOMMENDED OPERATING CONDITIONS ($V_{SS}=0V$)

PARAMETER		SYMBOL	RATINGS	UNIT
DC Supply Voltage		V_{DD}	3 ~ 18	V
Input Voltage		V_{IN}	0 ~ V_{DD}	V
Operating Temperature		T_A	-40 ~ 85	°C

■ DC ELECTRICAL CHARACTERISTICS (Note 2) ($T_A=25^\circ\text{C}$, unless otherwise specified)

PARAMETER		SYMBOL	CONDITIONS	MIN	TYP	MAX	UNIT	
Quiescent Device Current		I_{DD}	$V_{DD}=5V, V_{IN}=V_{DD}$ or V_{SS}			0.25	μA	
			$V_{DD}=10V, V_{IN}=V_{DD}$ or V_{SS}			0.5		
			$V_{DD}=15V, V_{IN}=V_{DD}$ or V_{SS}			1		
Output Voltage	Low	V_{OL}	$ I_O < 1\mu\text{A}$	$V_{DD}=5V$		0	0.05	V
				$V_{DD}=10V$		0	0.05	
				$V_{DD}=15V$		0	0.05	
	High	V_{OH}	$ I_O < 1\mu\text{A}$	$V_{DD}=5V$	4.95	5		V
				$V_{DD}=10V$	9.95	10		
				$V_{DD}=15V$	14.95	15		
Input Voltage	Low	V_{IL}	$ I_O < 1\mu\text{A}$	$V_{DD}=5V, V_O=4.5V$			1.0	V
				$V_{DD}=10V, V_O=9V$			2.0	
				$V_{DD}=15V, V_O=13.5V$			3.0	
	High	V_{IH}	$ I_O < 1\mu\text{A}$	$V_{DD}=5V, V_O=0.5V$	4.0			V
				$V_{DD}=10V, V_O=1V$	8.0			
				$V_{DD}=15V, V_O=1.5V$	12.0			
Output Current (Note 3)	Low	I_{OL}	$V_{DD}=5V, V_O=0.4V$	0.51	1.2		mA	
			$V_{DD}=10V, V_O=0.5V$	1.3	3.2			
			$V_{DD}=15V, V_O=1.5V$	3.4	12			
	High	I_{OH}	$V_{DD}=5V, V_O=4.6V$	-0.51	-1		mA	
			$V_{DD}=5V, V_O=2.5V$	-2.1	-4			
			$V_{DD}=10V, V_O=9.5V$	-1.3	-2.2			
Input Current		I_{IN}	$V_{DD}=15V, V_{IN}=0V$		-10^{-5}	-0.1	μA	
			$V_{DD}=15V, V_{IN}=15V$		10^{-5}	0.1		

■ AC ELECTRICAL CHARACTERISTICS (Note 1)

($T_A=25^\circ\text{C}$, $C_L=50\text{pF}$, $R_L=200\text{k}\Omega$, t_r and $t_f \leq 20\text{ ns}$, unless otherwise specified)

PARAMETER	SYMBOL	CONDITIONS	MIN	TYP	MAX	UNIT
Propagation Delay Time from Input to Output	t_{PHL} or t_{PLH}	$V_{DD}=5\text{V}$		55	110	ns
		$V_{DD}=10\text{V}$		30	60	
		$V_{DD}=15\text{V}$		25	50	
Transition Time	t_{THL} or t_{TLH}	$V_{DD}=5\text{V}$		70	200	ns
		$V_{DD}=10\text{V}$		35	100	
		$V_{DD}=15\text{V}$		30	80	
Average Input Capacitance	C_{IN}	Any Gate		7.5	15	pF

Notes: 1. AC Parameters are guaranteed by DC correlated testing.

2. I_{OH} and I_{OL} are tested one output at a time.

3. C_{PD} determines the no load AC power consumption of any CMOS device.

■ AC TEST CIRCUITS AND SWITCHING TIME WAVEFORMS

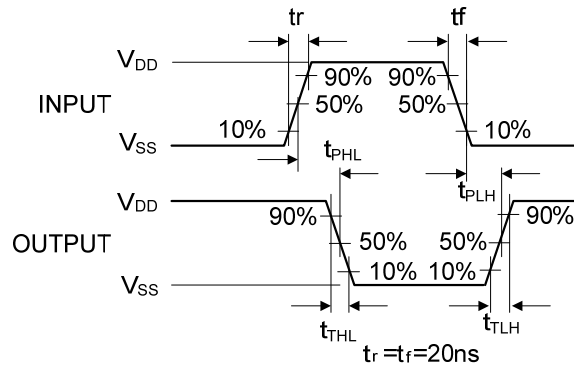

UTC assumes no responsibility for equipment failures that result from using products at values that exceed, even momentarily, rated values (such as maximum ratings, operating condition ranges, or other parameters) listed in products specifications of any and all UTC products described or contained herein. UTC products are not designed for use in life support appliances, devices or systems where malfunction of these products can be reasonably expected to result in personal injury. Reproduction in whole or in part is prohibited without the prior written consent of the copyright owner. The information presented in this document does not form part of any quotation or contract, is believed to be accurate and reliable and may be changed without notice.