

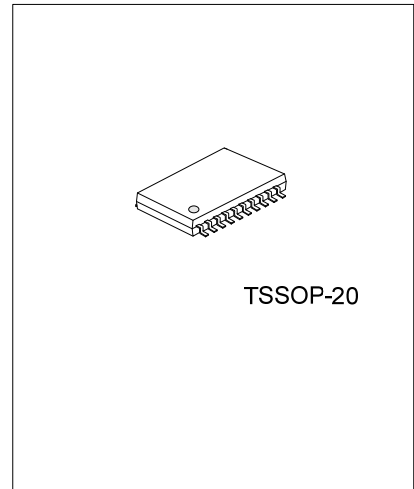

U74HC564

CMOS IC

OCTAL D-TYPE EDGE-TRIGGERED FLIP-FLOPS WITH 3-STATE OUTPUTS



DESCRIPTION

The UTC **74HC564** are octal D-type flip-flops featuring separated D-type inputs for each flip-flop and inverting 3-state outputs for bus-oriented applications.

FEATURES

- * Operation Voltage Range:2~6V
- * 3-state Inverting Outputs for Bus-oriented Applications
- * Common 3-state Output Enable Input

ORDERING INFORMATION

Ordering Number		Package	Packing
Lead Free	Halogen Free		
U74HC564L-P20-R	U74HC564G-P20-R	TSSOP-20	Tape Reel

<p>U74HC564G-P20-R</p> <p>(1)Packing Type</p> <p>(2)Package Type</p> <p>(3)Green Package</p>	<p>(1) R: Tape Reel</p> <p>(2) P20: TSSOP-20</p> <p>(3) G: Halogen Free and Lead Free, L: Lead Free</p>
--	---

MARKING

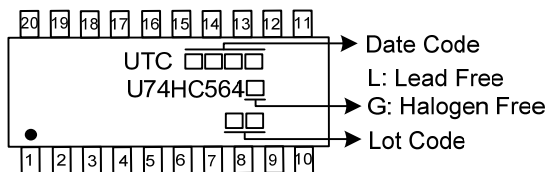

■ PIN CONFIGURATION

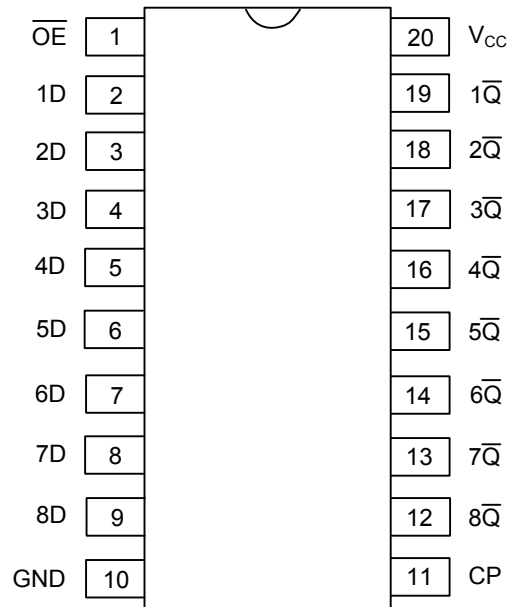

■ FUNCTION TABLE

INPUTS(\overline{OE})	INPUTS(CP)	INPUTS(D)	OUTPUT(\overline{Q})
L	\uparrow	H	L
L	\uparrow	L	H
L	L	X	\overline{Q}_0
H	X	X	Z

■ LOGIC DIAGRAM

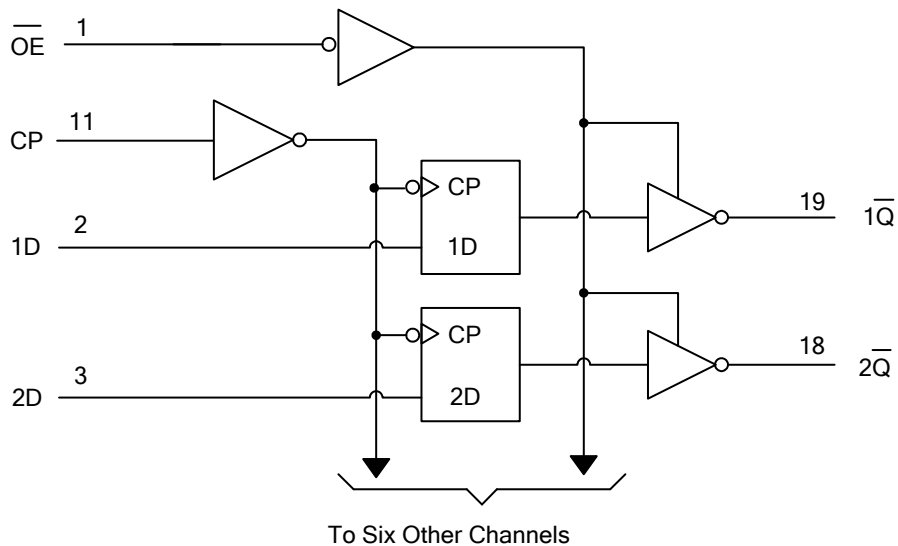

■ ABSOLUTE MAXIMUM RATING (Unless otherwise specified)

PARAMETER	SYMBOL	RATINGS	UNIT
Supply Voltage	V_{CC}	-0.5 ~ 7.0	V
Input Voltage	V_{IN}	-0.5 ~ $V_{CC}+0.5$	V
Output Voltage(active mode)	V_{OUT}	-0.5 ~ $V_{CC}+0.5$	V
Input Clamp Current ($V_{IN}<0$)	I_{IK}	±20	mA
Output Clamp Current ($V_{OUT}<0$)	I_{OK}	±20	mA
Output Current	I_{OUT}	±35	mA
V_{CC} or GND Current	I_{CC}	±70	mA
Storage Temperature	T_{STG}	-65 ~ +150	°C

Note: Absolute maximum ratings are those values beyond which the device could be permanently damaged. Absolute maximum ratings are stress ratings only and functional device operation is not implied.

■ RECOMMENDED OPERATING COMDITIONS

PARAMETER	SYMBOL	TEST CONDITIONS	MIN	TYP	MAX	UNIT
Supply Voltage	V_{CC}		2	5	6	V
Input Voltage	V_{IN}		0		V_{CC}	V
Output Voltage	V_{OUT}		0		V_{CC}	V
Input Transition Rise or Fall Rate	t_r	$V_{CC}=2V$			1000	ns
		$V_{CC}=4.5V$			500	ns
		$V_{CC}=6V$			400	ns
Operating Temperature	T_A		-40		+125	°C

■ ELECTRICAL CHARACTERISTICS (Unless otherwise specified)

PARAMETER	SYMBOL	TEST CONDITIONS	MIN	TYP	MAX	UNIT
High-Level input voltage	V_{IH}	$V_{CC}=2V$	1.5			V
		$V_{CC}=4.5V$	3.15			V
		$V_{CC}=6V$	4.2			V
Low-Lever output voltage	V_{IL}	$V_{CC}=2V$			0.5	V
		$V_{CC}=4.5V$			1.35	V
		$V_{CC}=6V$			1.8	V
High-Level Output Voltage	V_{OH}	$V_{CC}=2V, I_{OH}=-20\mu A$	1.9	1.998		V
		$V_{CC}=4.5V, I_{OH}=-20\mu A$	4.4	4.499		V
		$V_{CC}=6V, I_{OH}=-20\mu A$	5.9	5.999		V
		$V_{CC}=4.5V, I_{OH}=-6mA$	3.98	4.3		V
		$V_{CC}=6V, I_{OH}=-7.8mA$	5.48	5.8		V
Low-Level Output Voltage	V_{OL}	$V_{CC}=2V, I_{OL}=20\mu A$		0.002	0.1	V
		$V_{CC}=4.5V, I_{OL}=20\mu A$		0.001	0.1	V
		$V_{CC}=6V, I_{OL}=20\mu A$		0.001	0.1	V
		$V_{CC}=4.5V, I_{OL}=6mA$		0.17	0.26	V
		$V_{CC}=6V, I_{OL}=7.8mA$		0.15	0.26	V
Input Leakage Current	$I_{I(LEAK)}$	$V_{CC}=6V, V_{IN}=V_{CC}$ or GND		±0.1	±100	nA
Output OFF -state current	I_{OZ}	$V_{CC}=6V, V_{OUT}=V_{CC}$ or GND		±0.01	±0.5	µA
Quiescent Supply Current	I_Q	$V_{CC}=6V, V_{IN}=V_{CC}$ or GND, $I_{OUT}=0$			8	µA
Input Capacitance	C_{IN}	$V_{CC}=6V, V_{IN}=V_{CC}$ or GND		3	10	pF

■ TIMING REQUIREMENTS ($C_L=50\text{pF}$, unless otherwise specified)

PARAMETER	SYMBOL	TEST CONDITIONS	MIN	TYP	MAX	UNIT
Maximum Clock Frequency(CP)	f_{MAX}	$V_{\text{CC}}=2\text{V}$	6	11		MHz
		$V_{\text{CC}}=4.5\text{V}$	31	36		
		$V_{\text{CC}}=6\text{V}$	36	40		
Pulse duration, LE high	t_{W}	$V_{\text{CC}}=2\text{V}$	80			ns
		$V_{\text{CC}}=4.5\text{V}$	16			
		$V_{\text{CC}}=6\text{V}$	14			
Setup Time, data before LE ↓	t_{SU}	$V_{\text{CC}}=2\text{V}$	100			ns
		$V_{\text{CC}}=4.5\text{V}$	20			
		$V_{\text{CC}}=6\text{V}$	17			
Hold Time, data after LE ↓	t_{H}	$V_{\text{CC}}=2\text{V}$	5			ns
		$V_{\text{CC}}=4.5\text{V}$	5			
		$V_{\text{CC}}=6\text{V}$	5			

■ DYNAMIC CHARACTERISTICS ($C_L=50\text{pF}$, $R_L=1\text{k}\Omega$, unless otherwise specified)

PARAMETER	SYMBOL	TEST CONDITIONS	MIN	TYP	MAX	UNIT
Propagation delay from input (CP) to output (\bar{Q})	t_{PD} ($t_{\text{PLH}}/t_{\text{PHL}}$)	$V_{\text{CC}}=2\text{V}$		54	180	ns
		$V_{\text{CC}}=4.5\text{V}$		18	36	ns
		$V_{\text{CC}}=6\text{V}$		15	31	ns
3-state output enable time from input ($\overline{\text{OE}}$) to output (\bar{Q})	t_{EN} ($t_{\text{PZL}}/t_{\text{PZH}}$)	$V_{\text{CC}}=2\text{V}$		45	150	ns
		$V_{\text{CC}}=4.5\text{V}$		15	30	ns
		$V_{\text{CC}}=6\text{V}$		13	26	ns
3-state output disable time from input ($\overline{\text{OE}}$) to output (\bar{Q})	t_{DIS} ($t_{\text{PLZ}}/t_{\text{PHZ}}$)	$V_{\text{CC}}=2\text{V}$		45	150	ns
		$V_{\text{CC}}=4.5\text{V}$		15	30	ns
		$V_{\text{CC}}=6\text{V}$		13	26	ns
Output transition time, (\bar{Q})	t_{T} ($t_{\text{R}}/t_{\text{F}}$)	$V_{\text{CC}}=2\text{V}$		28	60	ns
		$V_{\text{CC}}=4.5\text{V}$		8	12	ns
		$V_{\text{CC}}=6\text{V}$		6	10	ns

■ OPERATING CHARACTERISTICS

PARAMETER	SYMBOL	TEST CONDITIONS	MIN	TYP	MAX	UNIT
Power Dissipation Capacitance	C_{PD}	No load		100		pF

TEST CIRCUIT AND WAVEFORMS

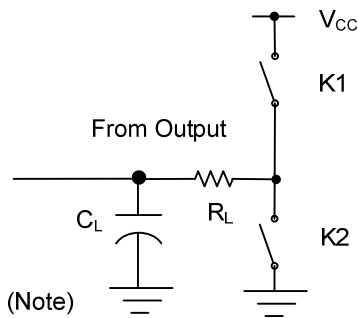

TEST	K1	K2
t_{PLH}/t_{PHL}	Open	Open
t_{PHZ}/t_{PZH}	Open	Close
t_{PLZ}/t_{PZL}	Close	Open

Note: C_L includes probe and jig capacitance.

$PRR \leq 1\text{MHz}$, $Z_o = 50\Omega$, $t_r \leq 6\text{ns}$, $t_f \leq 6\text{ns}$

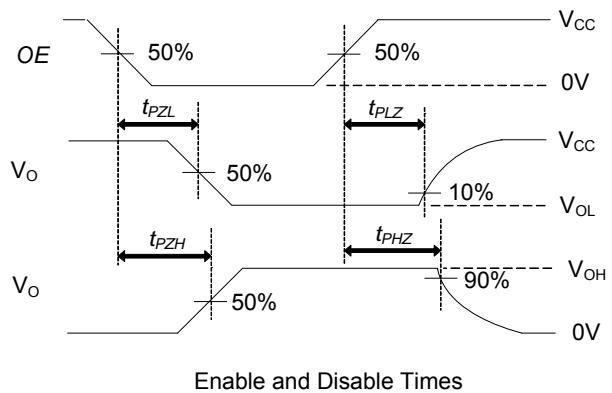
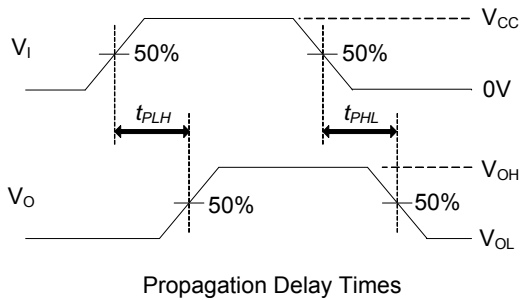
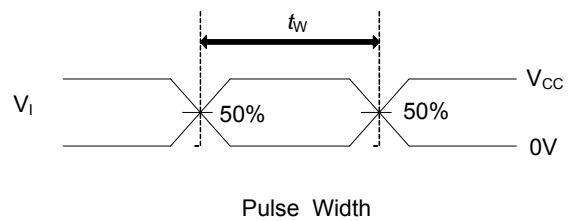
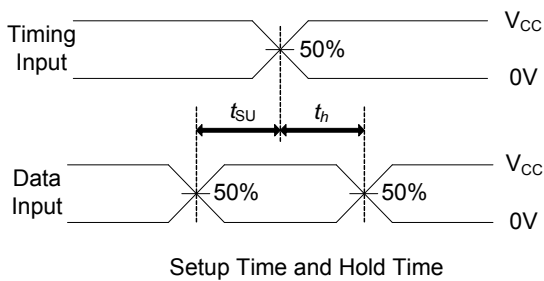

UTC assumes no responsibility for equipment failures that result from using products at values that exceed, even momentarily, rated values (such as maximum ratings, operating condition ranges, or other parameters) listed in products specifications of any and all UTC products described or contained herein. UTC products are not designed for use in life support appliances, devices or systems where malfunction of these products can be reasonably expected to result in personal injury. Reproduction in whole or in part is prohibited without the prior written consent of the copyright owner. UTC reserves the right to make changes to information published in this document, including without limitation specifications and product descriptions, at any time and without notice. This document supersedes and replaces all information supplied prior to the publication hereof.