



U74AHCT3G17

CMOS IC

NON-INVERTING SCHMITT TRIGGER

DESCRIPTION

The **U74AHCT3G17** is a high-speed triple Schmitt-trigger buffer. It provides three Schmitt-trigger buffers with the function $Y=A$. The trigger is capable of transforming slowly changing input signals into sharply defined, jitter-free output signals.

The **U74AHCT3G17** is compatible with TTL input switching levels and has supply voltage range from 4.5V to 5.5V.

FEATURES

- * Low power supply 1.0 μ A at 5.5V
- * Up to 5.5V inputs accept voltages
- * Symmetrical output impedance
- * High noise immunity
- * Balanced propagation delays

APPLICATION

- * Astable multivibrators
- * Monostable multivibrators
- * Wave and pulse shapers

ORDERING INFORMATION

Ordering Number		Package	Packing
Lead Free	Halogen Free		
U74AHCT3G17L-P08-R	U74AHCT3G17G-P08-R	TSSOP-8	Tape Reel

<p>U74AHCT3G17G-P08-R</p> <p>(1) Packing Type (2) Package Type (3) Green Package</p>	<p>(1) R: Tape Reel (2) P08: TSSOP-8 (3) G: Halogen Free and Lead Free, L: Lead Free</p>
--	--

MARKING

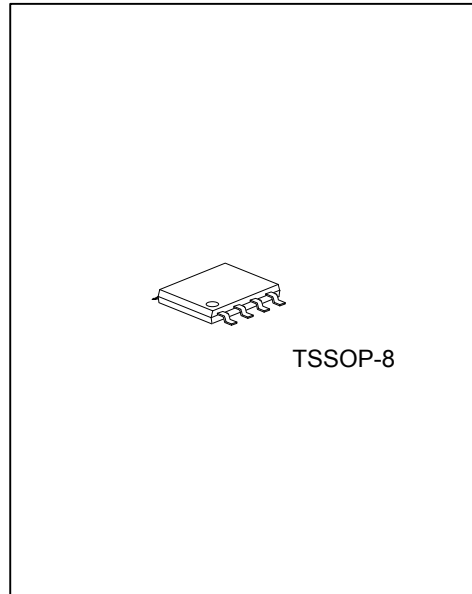
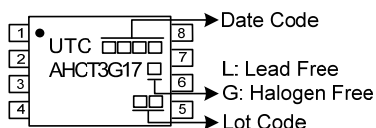

TSSOP-8

■ PIN CONFIGURATION

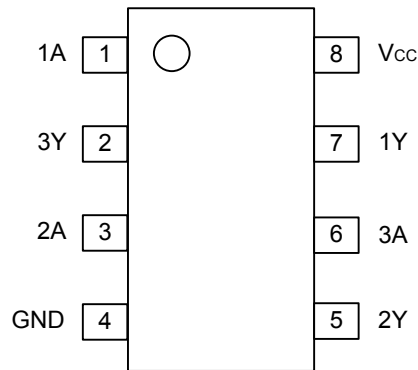

■ FUNCTION TABLE

INPUT	OUTPUT
nA	nY
L	L
H	H

■ LOGIC SYMBOL

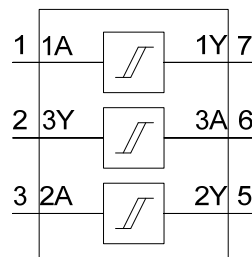

■ LOGIC DIAGRAM (one driver)

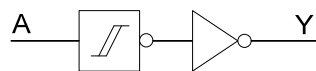

■ ABSOLUTE MAXIMUM RATING (unless otherwise specified)

PARAMETER	SYMBOL	RATINGS	UNIT
Supply Voltage	V_{CC}	-0.5~7.0	V
Input Voltage	V_{IN}	-0.5~7.0	V
Output Voltage	V_{OUT}	0~ V_{CC}	V
Input Diode Current ($V_I < -0.5V$)	I_{IK}	-20	mA
Output Diode Current ($V_O < -0.5V$ or $V_O > V_{CC} + 0.5V$)	I_{OK}	±20	mA
Output Source or Sink Current ($-0.5V < V_O < V_{CC} + 0.5V$)	I_{OUT}	±25	mA
V_{CC} or GND Current	I_{CC}	±75	mA
Power Dissipation	P_D	250	mW
Storage Temperature	T_{STG}	-65 ~ +150	°C

Note: 1. The input and output voltage ratings may be exceeded if the input and output current ratings are observed.

2. Absolute maximum ratings are those values beyond which the device could be permanently damaged.

Absolute maximum ratings are stress ratings only and functional device operation is not implied.

■ RECOMMENDED OPERATING CONDITIONS

PARAMETER	SYMBOL	MIN	TYP	MAX	UNIT
Supply Voltage	V_{CC}	4.5	5.0	5.5	V
Input Voltage	V_I	0		5.5	V
Output Voltage	V_O	0		V_{CC}	V
Operating Temperature	T_A	-40	+25	+125	°C

■ ELECTRICAL CHARACTERISTICS ($T_A = 25^\circ\text{C}$, unless otherwise specified)

PARAMETER	SYMBOL	TEST CONDITIONS	MIN	TYP	MAX	UNIT
High-Level Output Voltage	V_{OH}	$V_I = V_{IH}$ or V_{IL} , $I_O = -50\mu\text{A}$, $V_{CC} = 4.5V$	4.4	4.5		V
		$V_I = V_{IH}$ or V_{IL} , $I_O = -8.0\text{mA}$, $V_{CC} = 4.5V$	3.94			
Low-Level Output Voltage	V_{OL}	$V_I = V_{IH}$ or V_{IL} , $I_O = 50\mu\text{A}$, $V_{CC} = 4.5V$		0	0.1	V
		$V_I = V_{IH}$ or V_{IL} , $I_O = 8.0\text{mA}$, $V_{CC} = 4.5V$			0.36	
Input Leakage Current	$I_{I(LEAK)}$	$V_I = V_{CC}$ or GND, $V_{CC} = 5.5V$, $I_O = 0\text{A}$			0.1	μA
Quiescent Supply Current	I_{CC}	$V_I = V_{CC}$ or GND, $I_O = 0\text{A}$			1.0	μA
Additional Quiescent Supply Current	ΔI_{CC}	One input at 3.4V, $I_{OUT} = 0$, $V_{CC} = 5.5V$, Other inputs at V_{CC} or GND			1.35	mA
Input Capacitance	C_{IN}			1.5	10	pF

■ TRANSFER CHARACTERISTICS ($T_A = 25^\circ\text{C}$, unless otherwise specified)

PARAMETER	SYMBOL	TEST CONDITIONS	MIN	TYP	MAX	UNIT
Positive-going Threshold	V_{T+}	$V_{CC} = 4.5V$			2.0	V
		$V_{CC} = 5.5V$			2.0	
Negative-going Threshold	V_{T-}	$V_{CC} = 4.5V$	0.5			V
		$V_{CC} = 5.5V$	0.6			
Hysteresis ($V_{T+} - V_{T-}$)	V_H	$V_{CC} = 4.5V$	0.4		1.4	V
		$V_{CC} = 5.5V$	0.4		1.6	

■ AC CHARACTERISTICS ($T_A = 25^\circ\text{C}$, $\text{GND} = 0\text{V}$, $t_R = t_F \leq 3.0 \text{ ns}$)

PARAMETER	SYMBOL	TEST CONDITIONS	MIN	TYP	MAX	UNIT
Propagation Delay from Input (nA) to Output (nY)	t_{PLH}/t_{PHL} (t_{PD})	$V_{CC} = 4.5 \text{ to } 5.5\text{V}$, $C_L = 15 \text{ pF}$		4.1	7.0	ns
		$V_{CC} = 4.5 \text{ to } 5.5\text{V}$, $C_L = 50 \text{ pF}$		5.9	8.5	

■ OPERATING CHARACTERISTICS ($T_A = 25^\circ\text{C}$)

PARAMETER	SYMBOL	TEST CONDITIONS	TYP	UNIT
Power Dissipation Capacitance Per Buffer	C_{PD}	$C_L = 50\text{pF}$, $f = 1\text{MHz}$ (Note 1, 2)	12	pF

Notes:

- C_{PD} is used to determine the dynamic power dissipation (P_D in μW).

$$P_D = C_{PD} \times V_{CC}^2 \times f_i \times N + \sum(C_L \times V_{CC}^2 \times f_o) \text{ where:}$$

f_i = input frequency in MHz;

f_o = output frequency in MHz;

C_L = output load capacitance in pF;

V_{CC} = supply voltage in Volts;

N = number of inputs switching;

$\sum(C_L \times V_{CC}^2 \times f_o)$ = sum of the outputs.

- The condition is $V_I = \text{GND to } V_{CC}$.

■ WAVEFORMS

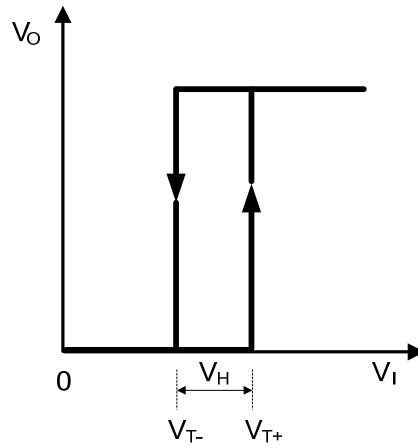

Fig.1 Transfer characteristic

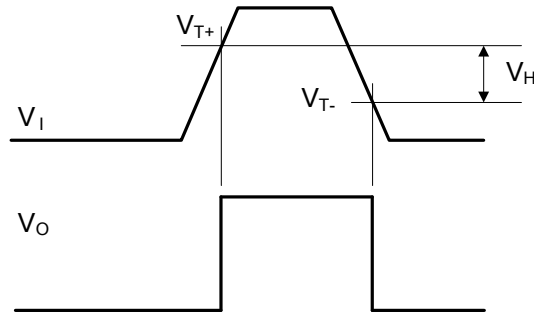
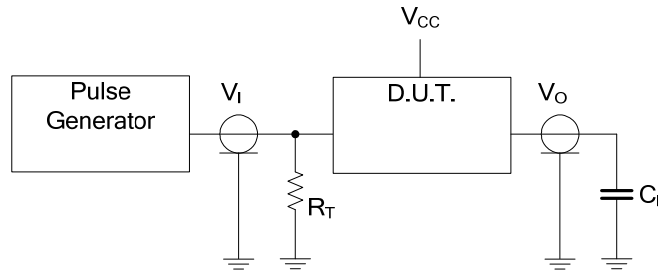

Fig.2 Definitions of V_{T+} , V_{T-} and V_H

■ TEST CIRCUIT AND WAVEFORMS



Definitions for test circuit:

C_L = Load capacitance including jig and probe capacitance.

R_T = Termination resistance should be equal to the output impedance Z_O of the pulse generator.

V_{CC}	INPUTS		V_M	C_L
	V_{IN}	t_R, t_F		
4.5 to 5.5V	GND to 3.0 V	$\leq 3ns$	1.5 V	15 or 50 pF

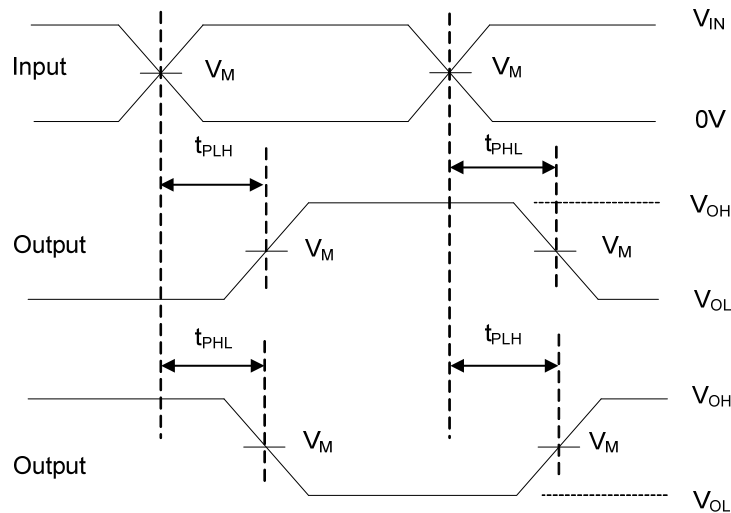

UTC assumes no responsibility for equipment failures that result from using products at values that exceed, even momentarily, rated values (such as maximum ratings, operating condition ranges, or other parameters) listed in products specifications of any and all UTC products described or contained herein. UTC products are not designed for use in life support appliances, devices or systems where malfunction of these products can be reasonably expected to result in personal injury. Reproduction in whole or in part is prohibited without the prior written consent of the copyright owner. UTC reserves the right to make changes to information published in this document, including without limitation specifications and product descriptions, at any time and without notice. This document supersedes and replaces all information supplied prior to the publication hereof.