



U74AHC4066

CMOS IC

QUADRUPLE BILATERAL ANALOG SWITCH

DESCRIPTION

The **U74AHC4066** is a quadruple bilateral analog switch which has 4 channels.

FEATURES

- * Operate From 2V to 5.5V
- * Max t_{PD} of 7ns at 5 V
- * Low Power Dissipation: $I_{CC}=20\mu A$ (Max.)
- * Low Input Current: $I_{I(L)}=1\mu A$ (Max.)

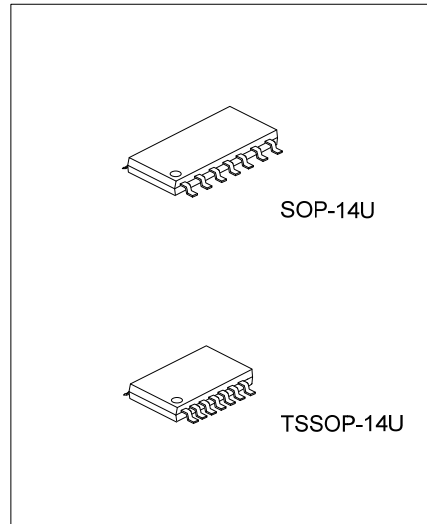

ORDERING INFORMATION

Ordering Number		Package	Packing
Lead Free	Halogen Free		
U74AHC4066L-UEA-R	U74AHC4066G-UEA-R	SOP-14U	Tape Reel
U74AHC4066L-UEB-R	U74AHC4066G-UEB-R	TSSOP-14U	Tape Reel

<p>U74AHC4066G-UEA-R</p> <p>(1) Packing Type (2) Package Type (3) Green Package</p>	<p>(1) R: Tape Reel (2) UEA: SOP-14U, UEB: TSSOP-14U (3) G: Halogen Free and Lead Free, L: Lead Free</p>
---	--

MARKING

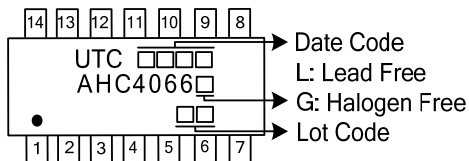

■ PIN CONFIGURATION

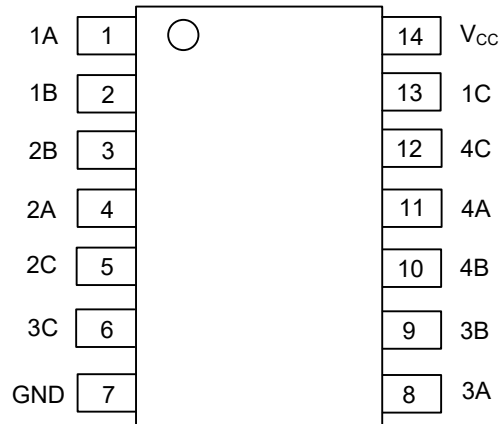

■ FUNCTION TABLE

INPUTS CONTROL (C)	SWITCH
H	ON
L	OFF

Note: H: HIGH voltage level;
L: LOW voltage level.

■ LOGIC DIAGRAM

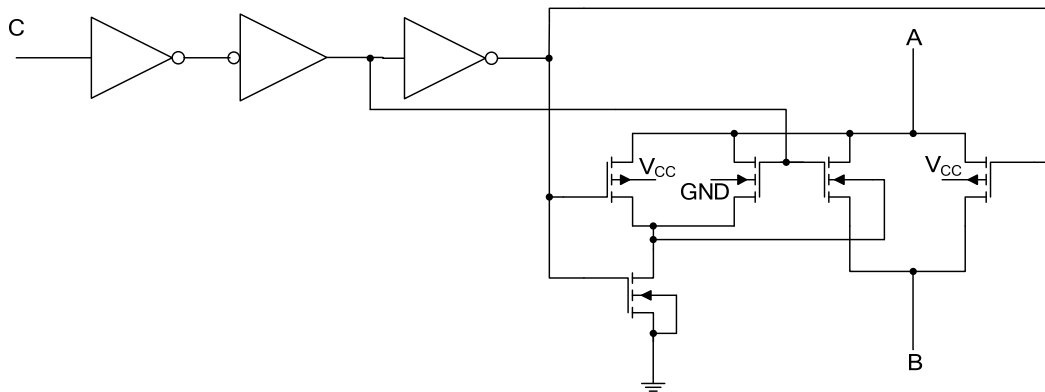

One Of Four Switches

■ ABSOLUTE MAXIMUM RATING (T_A=25°C, unless otherwise specified)

PARAMETER	SYMBOL	RATINGS	UNIT
Supply Voltage	V _{CC}	-0.5 ~ +7	V
Input Voltage	V _{IN}	-0.5 ~ +7	V
Switch I/O Voltage	V _{IO}	-0.5 ~ V _{CC} +0.5	V
V _{CC} or GND Current	I _{CC}	±50	mA
Output Clamp Current	I _{OK}	±50	mA
Input Clamp Current	I _{IK}	-20	mA
On-State Switch Current	I _T	±25	mA
Storage Temperature	T _{STG}	-65 ~ +150	°C

Note: Absolute maximum ratings are those values beyond which the device could be permanently damaged.

Absolute maximum ratings are stress ratings only and functional device operation is not implied.

■ THERMAL DATA

PARAMETER	SYMBOL	RATINGS	UNIT
Junction to Ambient	SOP-14U	95	°C/W
	TSSOP-14U	115	°C/W

Note: The package thermal impedance is calculated in accordance with JESD 51-7.

■ RECOMMENDED OPERATING CONDITIONS

PARAMETER	SYMBOL	TEST CONDITIONS	MIN	TYP	MAX	UNIT
Supply Voltage	V _{CC}		2		5.5	V
High-Level Input Voltage	V _{IH}	V _{CC} =2V	1.5			V
		V _{CC} =2.3V to 2.7V	V _{CC} ×0.7			
		V _{CC} =3V to 3.6V	V _{CC} ×0.7			
		V _{CC} =4.5V to 5.5V	V _{CC} ×0.7			
Low-Level Input Voltage	V _{IL}	V _{CC} =2V			0.5	V
		V _{CC} =2.3V to 2.7V			V _{CC} ×0.3	
		V _{CC} =3V to 3.6V			V _{CC} ×0.3	
		V _{CC} =4.5V to 5.5V			V _{CC} ×0.3	
Input Voltage	V _{IN}		0		5.5	V
Output Voltage	V _{OUT}		0		V _{CC}	V
Input Transition Rise or Fall Rate	Δt/Δv	V _{CC} =2.3V to 2.7V			200	ns/V
		V _{CC} =3V to 3.6V			100	
		V _{CC} =4.5V to 5.5V			20	
Operating Temperature	T _A		-40		+125	°C

■ ELECTRICAL CHARACTERISTICS (T_A=25°C, unless otherwise specified)

PARAMETER	SYMBOL	TEST CONDITIONS	MIN	TYP	MAX	UNIT
On-state Switch Resistance	R _{ON}	I _T =-1mA, V _{IN} =GND or V _{CC} , V _C = V _{IH}	V _{CC} =2.3V	38	180	Ω
			V _{CC} =3V	29	150	
			V _{CC} =4.5V	21	75	
Peak On-state Resistance	R _{ON(P)}	I _T =-1mA, V _{IN} =GND to V _{CC} , V _C = V _{IH}	V _{CC} =2.3V	143	500	Ω
			V _{CC} =3V	57	180	
			V _{CC} =4.5V	31	100	
Difference In On-state Resistance Between Switches	ΔR _{ON}	I _T =-1mA, V _{IN} =GND to V _{CC} , V _C = V _{IH}	V _{CC} =2.3V	6	30	Ω
			V _{CC} =3V	3	20	
			V _{CC} =4.5V	2	15	
Control Input Current	I _{I(CTL)}	V _{CC} =0 to 5.5V, V _C = 5.5V or GND			±0.1	μA
On-state Switch Leakage Current	I _{S(ON)}	V _{CC} =5.5V, V _{IN} = V _{CC} or GND, V _C = V _{IH}			±0.1	μA
Off-state Switch Leakage Current	I _{S(OFF)}	V _{CC} =5.5V, V _{IN} = V _{CC} and V _O =GND, or V _{IN} =GND and V _O = V _{CC} , V _C = V _{IL}			±0.1	μA
Quiescent Supply Current	I _Q	V _{CC} =5.5V, V _C =V _{CC} or GND			2	μA
Control Input Capacitance	C _{IC}			1.5		pF
Feed-through Capacitance	C _F			0.5		pF
Switch Input/Output Capacitance	C _{IO}			5.5		pF

■ SWITCHING CHARACTERISTICS (T_A=25°C, see test circuit and waveforms)

PARAMETER	SYMBOL	TEST CONDITIONS	MIN	TYP	MAX	UNIT
Propagation Delay Time, From A to B Or B to A	t _{PLH} /t _{PHL}	C _L =15pF	V _{CC} =2.5V±0.2V	1.2	10	ns
			V _{CC} =3.3V±0.3V	0.8	6	
			V _{CC} =5V±0.5V	0.3	4	
Propagation Delay Time, From A to B Or B to A	t _{PLH} /t _{PHL}	C _L =50pF	V _{CC} =2.5V±0.2V	2.6	12	ns
			V _{CC} =3.3V±0.3V	1.5	9	
			V _{CC} =5V±0.5V	0.6	6	
Switch Turn-on Time, From C to A or B	t _{PZL} /t _{PZH}	C _L =15pF	V _{CC} =2.5V±0.2V	3.3	15	ns
			V _{CC} =3.3V±0.3V	2.3	11	
			V _{CC} =5V±0.5V	1.6	7	
Switch Turn-on Time, From C to A or B	t _{PZL} /t _{PZH}	C _L =50pF	V _{CC} =2.5V±0.2V	4.2	25	ns
			V _{CC} =3.3V±0.3V	3	18	
			V _{CC} =5V±0.5V	2.1	12	
Switch Turn-off Time, From C to A or B	t _{PLZ} /t _{PHZ}	C _L =15pF	V _{CC} =2.5V±0.2V	6	15	ns
			V _{CC} =3.3V±0.3V	4.5	11	
			V _{CC} =5V±0.5V	3.2	7	
Switch Turn-off Time, From C to A or B	t _{PLZ} /t _{PHZ}	C _L =50pF	V _{CC} =2.5V±0.2V	9.6	25	ns
			V _{CC} =3.3V±0.3V	7.2	18	
			V _{CC} =5V±0.5V	5.1	12	

■ ANALOG SWITCHING CHARACTERISTICS (T_A=25°C, unless otherwise specified)

PARAMETER	SYMBOL	TEST CONDITIONS	MIN	TYP	MAX	UNIT	
Frequency Response (Switch On), From A to B Or B to A		C _L = 50pF, R _L = 600Ω, f _{IN} = 1MHz, 20log ₁₀ (V _O /V _I) = -3dB	V _{CC} = 2.3V		30		MHZ
			V _{CC} = 3V		35		
			V _{CC} = 4.5V		50		
Crosstalk (Between Any Switches), From A to B Or B to A		C _L = 50pF, R _L = 600Ω, f _{IN} = 1MHz	V _{CC} = 2.3V		-45		dB
			V _{CC} = 3V		-45		
			V _{CC} = 4.5V		-45		
Crosstalk (Control Input To Signal Output), From C to A or B		C _L = 50pF, R _L = 600Ω, f _{IN} = 1MHz	V _{CC} = 2.3V		15		mV
			V _{CC} = 3V		20		
			V _{CC} = 4.5V		50		
Feed-through Attenuation (Switch Off), From A to B Or B to A		C _L = 50pF, R _L = 600Ω, f _{IN} = 1MHz	V _{CC} = 2.3V		-40		dB
			V _{CC} = 3V		-40		
			V _{CC} = 4.5V		-40		
Sine-wave Distortion		C _L = 50pF, R _L = 10KΩ, f _{IN} = 1KHz	V _{CC} = 2.3V, V _I = 2 V _{P-P}		0.1		%
			V _{CC} = 3V, V _I = 2.5 V _{P-P}		0.1		
			V _{CC} = 4.5V, V _I = 4 V _{P-P}		0.1		

■ OPERATING CHARACTERISTICS (T_A=25°C, unless otherwise specified)

PARAMETER	SYMBOL	TEST CONDITIONS	MIN	TYP	MAX	UNIT
Power Dissipation Capacitance	C _{PD}	C _L = 50pF, f = 1MHz		4.5		pF

■ TEST CIRCUIT AND WAVEFORMS

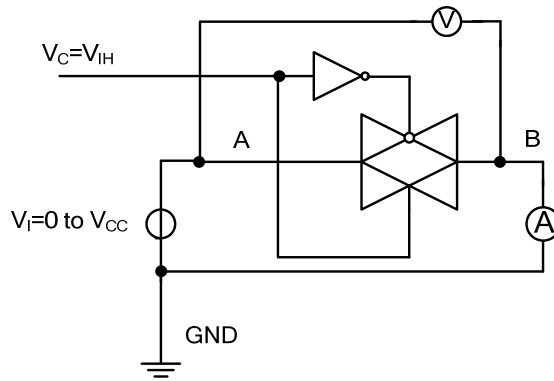

Test circuit for measuring ON-state resistance R_{ON}

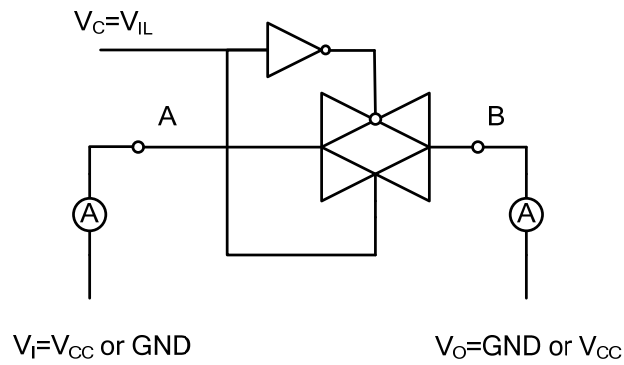

Test circuit for measuring OFF-state current

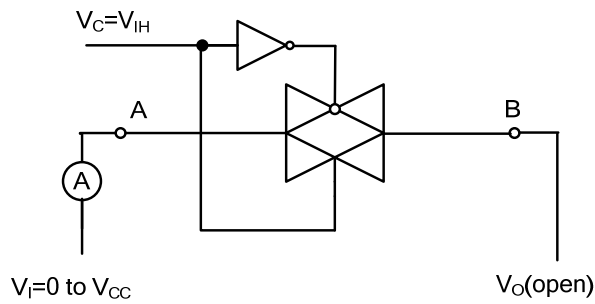

Test circuit for measuring ON-state current

■ TEST CIRCUIT AND WAVEFORMS (Cont.)

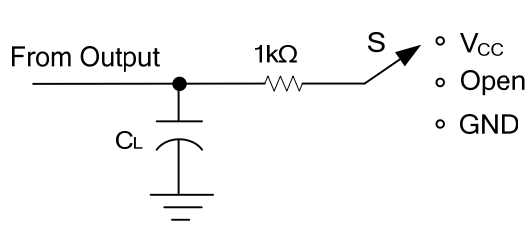

TEST	S	V _I
t _{PLH} /t _{PHL}	Open	Pulse
t _{PHZ} /t _{PZH}	GND	V _{CC}
t _{PLZ} /t _{PZL}	V _{CC}	GND

Test circuit for measuring propagation delay time, switching time

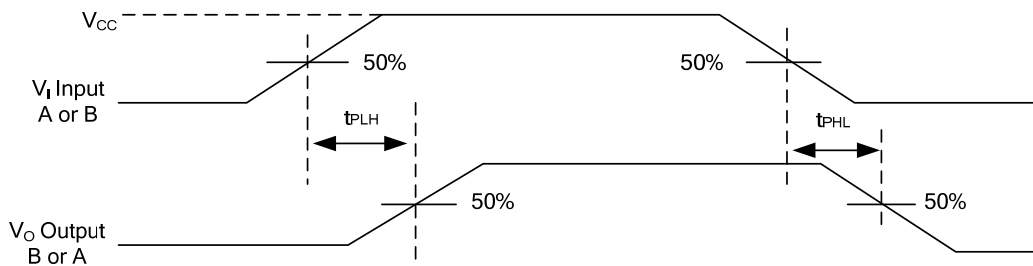

Waveforms showing the Input(V_i) to Output(V_o) propagation delays

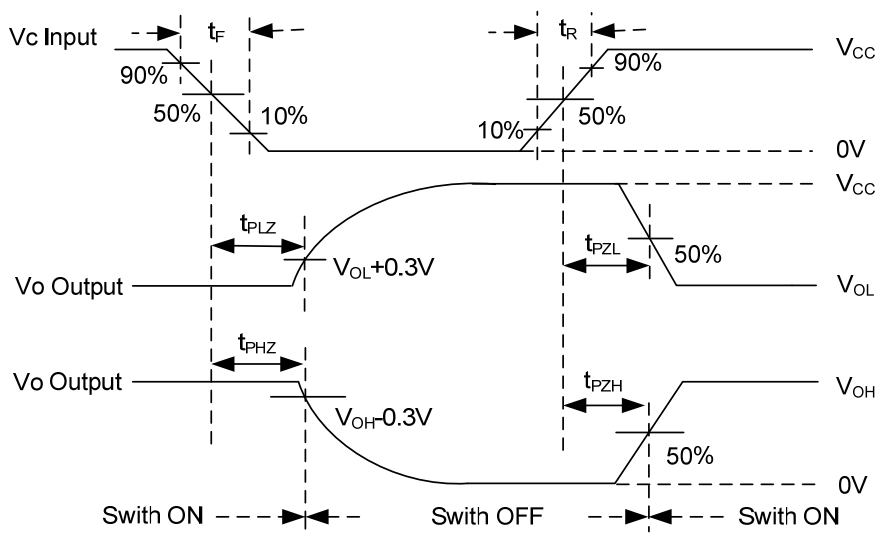

Waveforms showing the turn-on and turn-off times

Note: C_L includes probe and jig capacitance.

All input pulses are supplied by generators having the following characteristics: PRR ≤ 1MHz, Z_o = 50Ω, tr ≤ 3ns, tf ≤ 3ns.

UTC assumes no responsibility for equipment failures that result from using products at values that exceed, even momentarily, rated values (such as maximum ratings, operating condition ranges, or other parameters) listed in products specifications of any and all UTC products described or contained herein. UTC products are not designed for use in life support appliances, devices or systems where malfunction of these products can be reasonably expected to result in personal injury. Reproduction in whole or in part is prohibited without the prior written consent of the copyright owner. UTC reserves the right to make changes to information published in this document, including without limitation specifications and product descriptions, at any time and without notice. This document supersedes and replaces all information supplied prior to the publication hereof.