



U74AHC374

CMOS IC

OCTAL EDGE-TRIGGERED D-TYPE FLIP-FLOPS WITH 3-STATE OUTPUTS

DESCRIPTION

The **U74AHC374** is a octal edge-triggered D-type flip-flops with 3-state outputs and it has 8 channels.

When the \overline{OE} input is low, on the positive transition of the clock (CLK) input, the Q outputs are set to the logic levels of the data (D) inputs.

When the \overline{OE} input is high, the outputs are in the high-impedance.

To ensure the high-impedance state during power up or power down, \overline{OE} should be tied to V_{CC} through a pull-up resistor; the minimum value of the resistor is determined by the current-sinking capability of the driver.

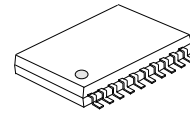

TSSOP-20

FEATURES

- * Operate from 2V to 5.5V
- * Max t_{PD} of 12.7ns at $V_{CC}=3.3V, C_L=15pF$
- * Max I_{CC} of 4uA
- * Typ $V_{OL} < 0.36V$ at $V_{CC}=4.5V, I_o=8mA, T_A=25^\circ C$
- * Typ $V_{OH} > 3.94V$ at $V_{CC}=4.5V, I_o=-8mA, T_A=25^\circ C$

ORDERING INFORMATION

Ordering Number		Package	Packing
Lead Free	Halogen Free		
U74AHC373L-P20-R	U74AHC373G-P20-R	TSSOP-20	Tape Reel

<p>U74AHC373G-P20-R</p> <p>(1) Packing Type (2) Package Type (3) Green Package</p>	<p>(1) R: Tape Reel (2) P20: TSSOP-20 (3) G: Halogen Free and Lead Free, L: Lead Free</p>
--	---

MARKING

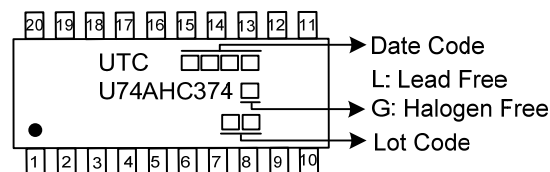

■ PIN CONFIGURATION

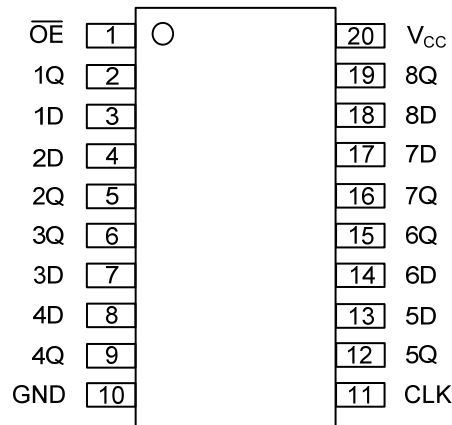

■ FUNCTION TABLE

INPUTS(\overline{OE})	INPUTS(CLK)	INPUTS(D)	OUTPUT(Q)
L	↑	H	H
L	↑	L	L
L	H or L	X	Q0
H	X	X	Z

■ LOGIC SYMBOL

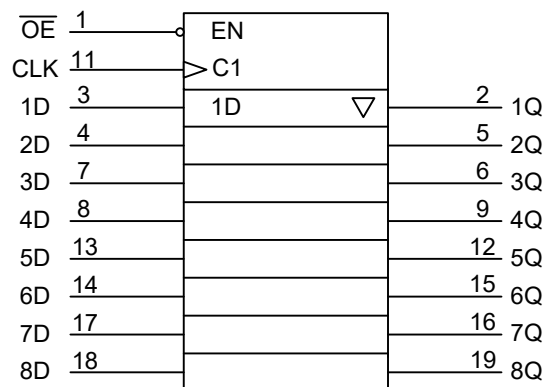

■ LOGIC DIAGRAM

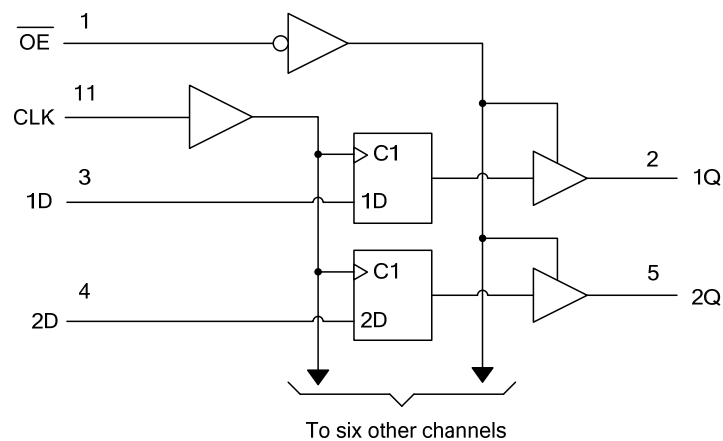

■ ABSOLUTE MAXIMUM RATING (Unless otherwise specified)

PARAMETER	SYMBOL	RATINGS	UNIT
Supply Voltage	V_{CC}	-0.5 ~ 7	V
Input Voltage	V_{IN}	-0.5 ~ 7	V
Output Voltage	V_{OUT}	-0.5 ~ $V_{CC} + 0.5$	V
V_{CC} or GND Current	I_{CC}	±75	mA
Output Current	I_{OUT}	±25	mA
Input Clamp Current	I_{IK}	-20	mA
Output Clamp Current	I_{OK}	±20	mA
Storage Temperature	T_{STG}	-65 ~ + 150	°C

Note: Absolute maximum ratings are those values beyond which the device could be permanently damaged.

Absolute maximum ratings are stress ratings only and functional device operation is not implied.

■ RECOMMENDED OPERATING CONDITIONS (Unless otherwise specified)

PARAMETER	SYMBOL	TEST CONDITIONS	MIN	TYP	MAX	UNIT
Supply Voltage	V_{CC}		2		5.5	V
High-level Input Voltage	V_{IH}	$V_{CC}=2V$	1.5			V
		$V_{CC}=3V$	2.1			
		$V_{CC}=5.5V$	3.85			
Low-level Input Voltage	V_{IL}	$V_{CC}=2V$			0.5	V
		$V_{CC}=3V$			0.9	
		$V_{CC}=5.5V$			1.65	
Input Voltage	V_{IN}		0		V_{CC}	V
Output Voltage	V_{OUT}	High or low state	0		V_{CC}	V
High-level Output Current	I_{OH}	$V_{CC} = 2 V$			-50	μA
		$V_{CC} = 3.3 V \pm 0.3 V$			-4	mA
		$V_{CC} = 5 V \pm 0.5 V$			-8	
Low-level Output Current	I_{OL}	$V_{CC} = 2 V$			50	μA
		$V_{CC} = 3.3 V \pm 0.3 V$			4	mA
		$V_{CC} = 5 V \pm 0.5 V$			8	
Input Rise or Fall Times	$\Delta t/\Delta v$	$V_{CC} = 3.3 V \pm 0.3 V$			100	ns
		$V_{CC} = 5 V \pm 0.5 V$			20	
Operating Free-air Temperature	T_A		-40		+125	°C

■ ELECTRICAL CHARACTERISTICS (Unless otherwise specified)

PARAMETER	SYMBOL	TEST CONDITIONS	MIN	TYP	MAX	UNIT
Output Voltage High-Level	V_{OH}	$V_{CC}=2V, I_{OH}=-50\mu A$	1.9	2		V
		$V_{CC}=3V, I_{OH}=-50\mu A$	2.9	3		
		$V_{CC}=4.5V, I_{OH}=-50\mu A$	4.4	4.5		
		$V_{CC}=3V, I_{OH}=-4mA$	2.58			
		$V_{CC}=4.5V, I_{OH}=-8mA$	3.94			
Output Voltage Low-Level	V_{OL}	$V_{CC}=2V, I_{OL}=50\mu A$			0.1	V
		$V_{CC}=3V, I_{OL}=50\mu A$			0.1	
		$V_{CC}=4.5V, I_{OL}=50\mu A$			0.1	
		$V_{CC}=3V, I_{OL}=4mA$			0.36	
		$V_{CC}=4.5V, I_{OL}=8mA$			0.36	
Input Leakage Current	$I_{I(LEAK)}$	$V_{CC} = 0$ to 5.5V, $V_{IN}=5.5V$ or GND			±0.1	μA
3-state Leakage Current	I_{OZ}	$V_{CC}=5.5V, V_{OUT}=V_{CC}$ or GND			±0.25	μA
Quiescent Supply Current	I_{CC}	$V_{CC}=5.5V, V_{IN}=V_{CC}$ or GND, $I_{OUT}=0$			4	μA
Input Capacitance	C_I	$V_{CC}=5V, V_{IN}=V_{CC}$ or GND		4	10	pF
Output Capacitance	C_O	$V_{CC}=5V, V_{OUT}=V_{CC}$ or GND		6		pF

■ SWITCHING CHARACTERISTICS (See TEST CIRCUIT AND WAVEFORMS)

PARAMETER	SYMBOL	TEST CONDITIONS	MIN	TYP	MAX	UNIT	
From CLK to Q	t_{PLH}/t_{PHL}	$V_{CC} = 3.3V \pm 0.3V$	$C_L = 15pF$		8.1	12.7	ns
			$C_L = 50pF$		10.6	16.2	
		$V_{CC} = 5V \pm 0.5V$	$C_L = 15pF$		5.4	8.1	
			$C_L = 50pF$		6.9	10.1	
From \overline{OE} to Q	t_{PZL}/t_{PZH}	$V_{CC} = 3.3V \pm 0.3V$	$C_L = 15pF$		7.1	11	ns
			$C_L = 50pF$		9.6	14.5	
		$V_{CC} = 5V \pm 0.5V$	$C_L = 15pF$		5.1	7.6	
			$C_L = 50pF$		6.6	9.6	
From \overline{OE} to Q	t_{PLZ}/t_{PHZ}	$V_{CC} = 3.3V \pm 0.3V$	$C_L = 15pF$		7.5	10.5	ns
			$C_L = 50pF$		10.2	14	
		$V_{CC} = 5V \pm 0.5V$	$C_L = 15pF$		4.6	6.8	
			$C_L = 50pF$		6.1	8.8	
Maximum Clock Frequency	f_{MAX}	$V_{CC} = 3.3V \pm 0.3V$	$C_L = 15pF$	80	130		MHz
			$C_L = 50pF$	55	85		
		$V_{CC} = 5V \pm 0.5V$	$C_L = 15pF$	130	185		
			$C_L = 50pF$	85	120		
Pulse Width	t_W	$V_{CC} = 3.3V \pm 0.3V$		5		ns	
		$V_{CC} = 5V \pm 0.5V$		5			
Setup Time	t_{SU}	$V_{CC} = 3.3V \pm 0.3V$		4.5		ns	
		$V_{CC} = 5V \pm 0.5V$		3			
Hold Time	t_H	$V_{CC} = 3.3V \pm 0.3V$		2		ns	
		$V_{CC} = 5V \pm 0.5V$		2			

■ OPERATING CHARACTERISTICS (Unless otherwise specified)

PARAMETER	SYMBOL	TEST CONDITIONS	RATINGS	UNIT
Power Dissipation Capacitance	C_{PD}	No load, $V_{CC} = 5V$, $f = 1MHz$	32	pF

■ TEST CIRCUIT AND WAVEFORMS

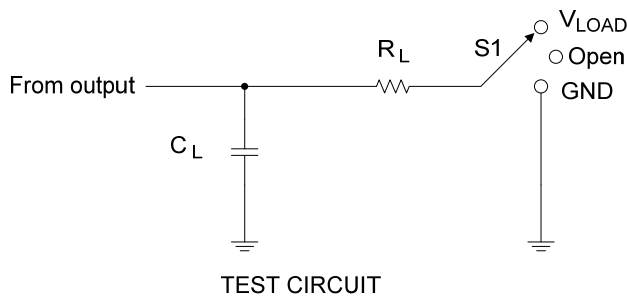

TEST	S1
t_{PLH}/t_{PHL}	Open
t_{PLZ}/t_{PZL}	V_{LOAD}
t_{PHZ}/t_{PZH}	GND

V_{CC}	Input		V_M	V_{LOAD}	C_L	R_L	V_{Δ}
	V_{IN}	t_R, t_F					
$3.3V \pm 0.3V$	V_{CC}	$\leq 3ns$	$V_{CC}/2$	V_{CC}	15pF	1k Ω	0.3V
					50pF		
$5V \pm 0.5V$	V_{CC}	$\leq 3ns$	$V_{CC}/2$	V_{CC}	15pF	1k Ω	0.5V
					50pF		

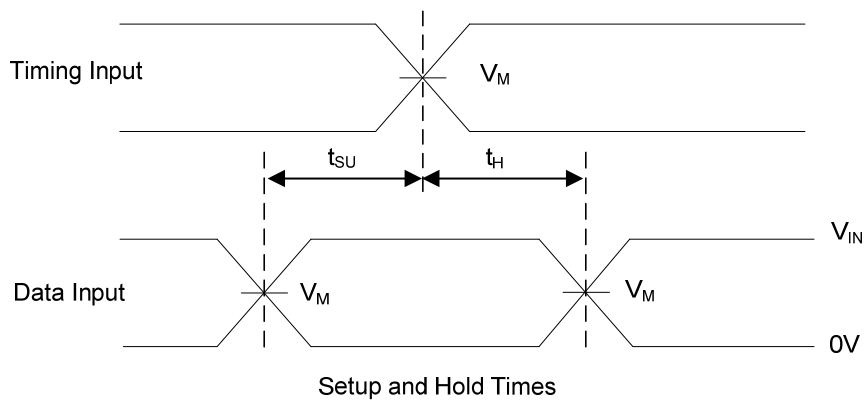
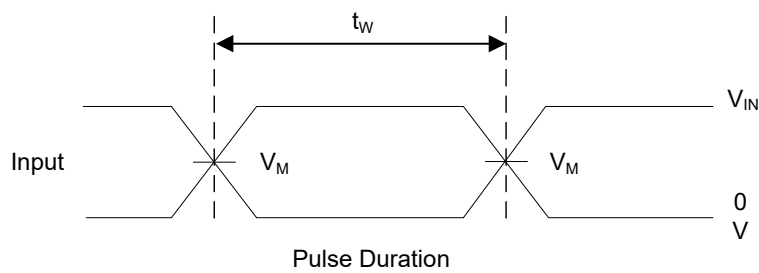

■ TEST CIRCUIT AND WAVEFORMS (Cont.)

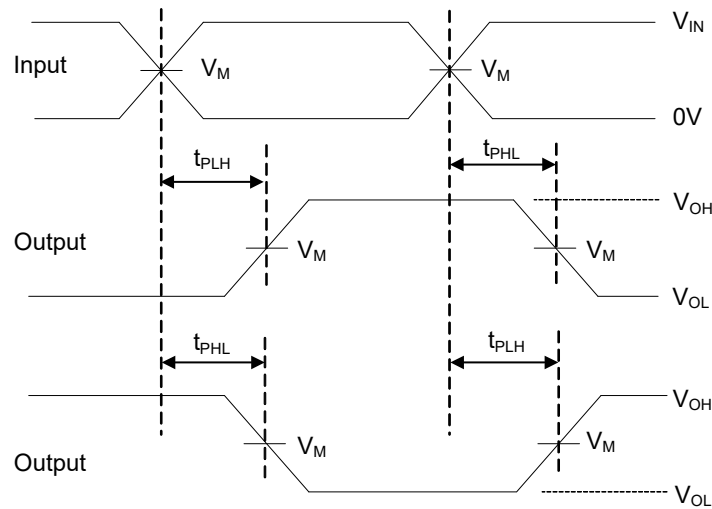

Voltage Waveforms Propagation Delay Times

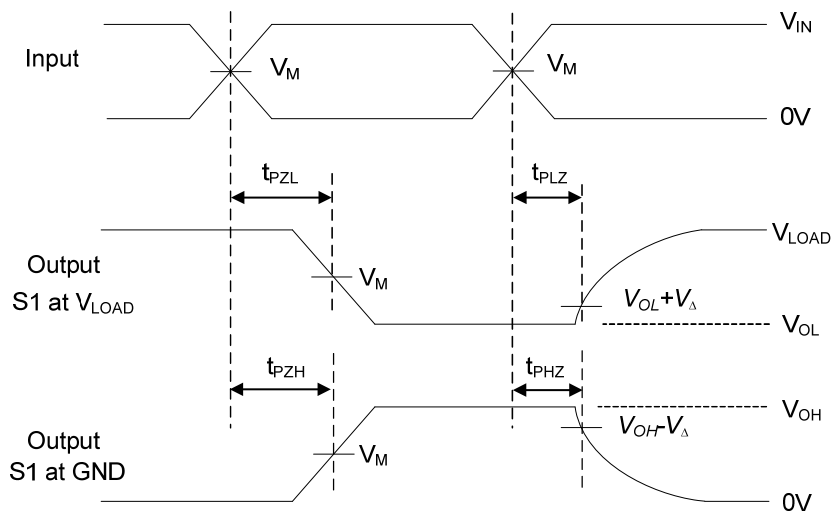

Voltage Waveforms Enable and Disable Times

Note: A. C_L includes probe and jig capacitance.

B. $P_{RR} \leq 1\text{MHz}$, $Z_O = 50\Omega$, $t_R \leq 3\text{ns}$, $t_F \leq 3\text{ns}$.

UTC assumes no responsibility for equipment failures that result from using products at values that exceed, even momentarily, rated values (such as maximum ratings, operating condition ranges, or other parameters) listed in products specifications of any and all UTC products described or contained herein. UTC products are not designed for use in life support appliances, devices or systems where malfunction of these products can be reasonably expected to result in personal injury. Reproduction in whole or in part is prohibited without the prior written consent of the copyright owner. UTC reserves the right to make changes to information published in this document, including without limitation specifications and product descriptions, at any time and without notice. This document supersedes and replaces all information supplied prior to the publication hereof.