



## U74AHC158

CMOS IC

### QUADRUPLE 2-LINE TO 1-LINE DATA SELECTORS/MULTIPLEXERS

#### DESCRIPTION

The **U74AHC158** is a quadruple 2-line to 1-line data selector/multiplexer. When  $\bar{G}$  is high, all outputs are high. When  $\bar{G}$  is low, a 4-bit word is selected from one of with two sources and is routed to the four outputs. The device provides inverted data.

#### FEATURES

- \* Wide supply voltage range from 2V to 5.5V
- \* Max  $t_{pd}$  of 4.1ns from A or B to Y at 5V,  $C_L=15pF$
- \* Low power consumption,  $I_{CC} = 4 \mu A$  (Max.) at 5.5V
- \*  $\pm 8$  mA output driver at 5V

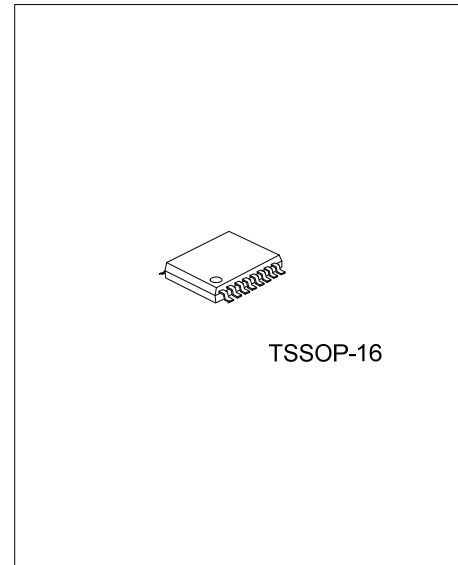

#### ORDERING INFORMATION

Ordering Number		Package	Packing
Lead Free	Halogen Free		
U74AHC158L-P16-R	U74AHC158G-P16-R	TSSOP-16	Tape Reel

<p>U74AHC158G-P16-R</p> <p>(1)Packing Type (2)Package Type (3)Green Package</p>	<p>(1) R: Tape Reel (2) P16: TSSOP-16 (3) G: Halogen Free and Lead Free, L: Lead Free</p>
---	---

#### MARKING

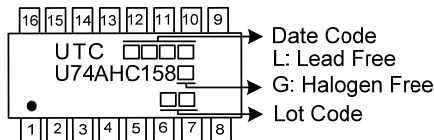

■ PIN CONFIGURATION

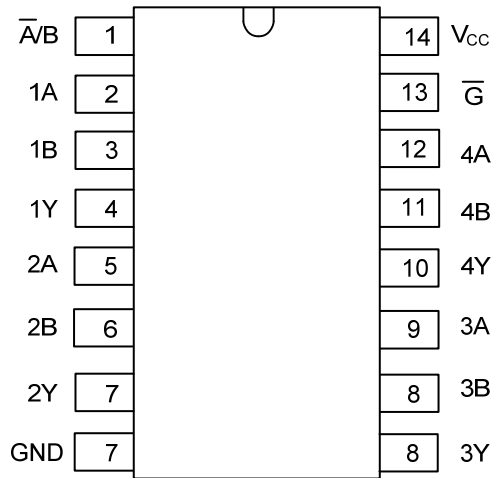

■ FUNCTION TABLE

INPUTS				OUTPUTS
$\bar{G}$	$\bar{A}/B$	A	B	Y
H	X	X	X	H
L	L	L	X	H
L	L	H	X	L
L	H	X	L	H
L	H	X	H	L

■ LOGIC DIAGRAM

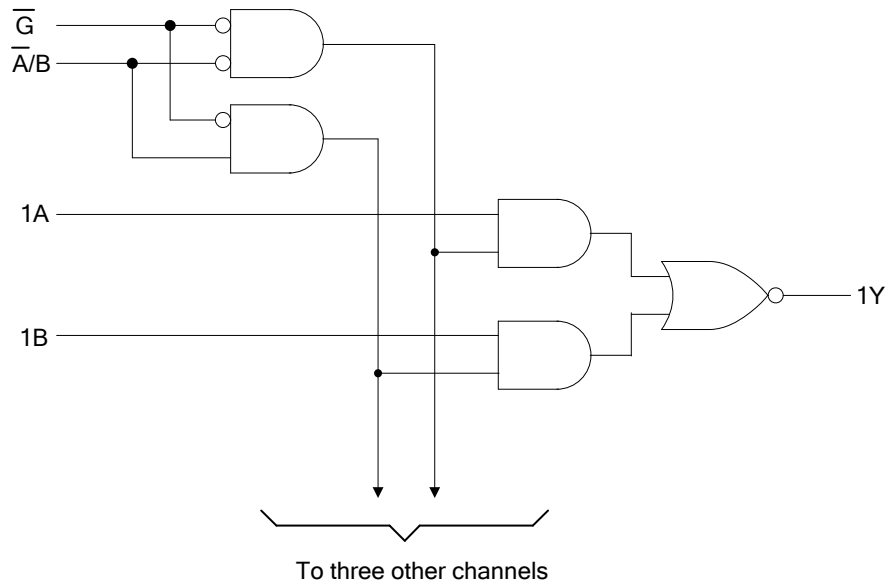

■ ABSOLUTE MAXIMUM RATING (Unless otherwise specified)

PARAMETER	SYMBOL	RATINGS	UNIT
Supply Voltage Range	$V_{CC}$	-0.5 ~ 7	V
Input Voltage Range	$V_{IN}$	-0.5 ~ 7	V
Output Voltage Range	$V_{OUT}$	-0.5 ~ $V_{CC} + 0.5$	V
Input Clamp Current ( $V_{IN} < 0$ )	$I_{IK}$	-20	mA
Output Clamp Current ( $V_{OUT} < 0$ , or $V_{OUT} > V_{CC}$ )	$I_{OK}$	$\pm 20$	mA
Output Current	$I_{OUT}$	$\pm 25$	mA
$V_{CC}$ or GND Current	$I_{CC}$	$\pm 50$	mA
Storage Temperature	$T_{STG}$	-65 ~ +150	°C

Note: 1. The input and output voltage ratings may be exceeded if the input and output current ratings are observed.  
 2. Absolute maximum ratings are those values beyond which the device could be permanently damaged.  
 Absolute maximum ratings are stress ratings only and functional device operation is not implied.

■ RECOMMENDED OPERATING CONDITIONS (Unless otherwise specified)

PARAMETER	SYMBOL	CONDITIONS	MIN	TYP	MAX	UNIT
Supply Voltage	$V_{CC}$		2		5.5	V
High-Level Input Voltage	$V_{IH}$	$V_{CC} = 2V$	1.5			V
		$V_{CC} = 3V$	2.1			
		$V_{CC} = 5.5V$	3.85			
Low-Level Input Voltage	$V_{IL}$	$V_{CC} = 2V$			0.5	V
		$V_{CC} = 3V$			0.9	
		$V_{CC} = 5.5V$			1.65	
Input Voltage	$V_{IN}$		0		5.5	V
Output Voltage	$V_{OUT}$		0		$V_{CC}$	V
High-level Output Current	$I_{OH}$	$V_{CC} = 2V$			-50	$\mu A$
		$V_{CC} = 3.3 \pm 0.3V$			-4	mA
		$V_{CC} = 5 \pm 0.5V$			-8	
Low-level Output Current	$I_{OL}$	$V_{CC} = 2V$			50	$\mu A$
		$V_{CC} = 3.3 \pm 0.3V$			4	mA
		$V_{CC} = 5 \pm 0.5V$			8	
Input Transition Rise or Fall Rate	$\Delta t / \Delta v$	$V_{CC} = 3.3 \pm 0.3V$			100	ns/V
		$V_{CC} = 5 \pm 0.5V$			20	
Operating Temperature	$T_A$		-40		+125	°C

■ THERMAL DATA

PARAMETER	SYMBOL	RATINGS	UNIT
Junction to Ambient	$\theta_{JA}$	108	°C/W

■ ELECTRICAL CHARACTERISTICS (Unless otherwise specified)

PARAMETER	SYMBOL	TEST CONDITIONS	MIN	TYP	MAX	UNIT
High-Level Output Voltage	$V_{OH}$	$V_{CC}=2V, I_{OH}=-50\mu A$	1.9	2		V
		$V_{CC}=3V, I_{OH}=-50\mu A$	2.9	3		
		$V_{CC}=4.5V, I_{OH}=-50\mu A$	4.4	4.5		
		$V_{CC}=3V, I_{OH}=-4mA$	2.58			
		$V_{CC}=4.5V, I_{OH}=-8mA$	3.94			
Low-Level Output Voltage	$V_{OL}$	$V_{CC}=2V, I_{OL}=50\mu A$			0.1	V
		$V_{CC}=3V, I_{OL}=50\mu A$			0.1	
		$V_{CC}=4.5V, I_{OL}=50\mu A$			0.1	
		$V_{CC}=3V, I_{OL}=4mA$			0.36	
		$V_{CC}=4.5V, I_{OL}=8mA$			0.36	
Input Leakage Current (A or B inputs)	$I_{I(LEAK)}$	$V_{IN} = 5.5V$ or GND, $V_{CC} = 0$ to 5.5V			$\pm 0.1$	$\mu A$
Quiescent Supply Current	$I_{CC}$	$V_{IN} = V_{CC}$ or GND, $I_{OUT} = 0$ , $V_{CC} = 5.5V$			4	$\mu A$
Input Capacitance	$C_{IN}$	$V_{IN} = V_{CC}$ or GND, $V_{CC}=5V$		2	10	pF

■ SWITCHING CHARACTERISTICS (Unless otherwise specified)

PARAMETER	SYMBOL	TEST CONDITIONS	MIN	TYP	MAX	UNIT
<b><math>V_{CC} = 3.3V \pm 0.3V</math></b>						
Propagation delay from input A or B to output Y, $t_{PD}$	$t_{PLH}$	$C_L=15pF, R_L=1k\Omega$		6.2	9.7	ns
		$C_L=50pF, R_L=1k\Omega$		8.7	13.2	
	$t_{PHL}$	$C_L=15pF, R_L=1k\Omega$		6.2	9.7	ns
		$C_L=50pF, R_L=1k\Omega$		8.7	13.2	
Propagation delay from input $\bar{A}/\bar{B}$ to output Y, $t_{PD}$	$t_{PLH}$	$C_L=15pF, R_L=1k\Omega$		8.4	13.2	ns
		$C_L=50pF, R_L=1k\Omega$		10.9	16.7	
	$t_{PHL}$	$C_L=15pF, R_L=1k\Omega$		8.4	13.2	ns
		$C_L=50pF, R_L=1k\Omega$		10.9	16.7	
Propagation delay from input $\bar{G}$ to output Y, $t_{PD}$	$t_{PLH}$	$C_L=15pF, R_L=1k\Omega$		8.7	13.6	ns
		$C_L=50pF, R_L=1k\Omega$		11.2	17.1	
	$t_{PHL}$	$C_L=15pF, R_L=1k\Omega$		8.7	13.6	ns
		$C_L=50pF, R_L=1k\Omega$		11.2	17.1	
<b><math>V_{CC} = 5V \pm 0.5V</math></b>						
Propagation delay from input A or B to output Y, $t_{PD}$	$t_{PLH}$	$C_L=15pF, R_L=1k\Omega$		4.1	6.4	ns
		$C_L=50pF, R_L=1k\Omega$		5.6	8.4	
	$t_{PHL}$	$C_L=15pF, R_L=1k\Omega$		4.1	6.4	ns
		$C_L=50pF, R_L=1k\Omega$		5.6	8.4	
Propagation delay from input $\bar{A}/\bar{B}$ to output Y, $t_{PD}$	$t_{PLH}$	$C_L=15pF, R_L=1k\Omega$		5.3	8.1	ns
		$C_L=50pF, R_L=1k\Omega$		6.8	10.1	
	$t_{PHL}$	$C_L=15pF, R_L=1k\Omega$		5.3	8.1	ns
		$C_L=50pF, R_L=1k\Omega$		6.8	10.1	
Propagation delay from input $\bar{G}$ to output Y, $t_{PD}$	$t_{PLH}$	$C_L=15pF, R_L=1k\Omega$		5.6	8.6	ns
		$C_L=50pF, R_L=1k\Omega$		7.1	10.6	
	$t_{PHL}$	$C_L=15pF, R_L=1k\Omega$		5.6	8.6	ns
		$C_L=50pF, R_L=1k\Omega$		7.1	10.6	

■ OPERATING CHARACTERISTICS (Unless otherwise specified)

PARAMETER	SYMBOL	TEST CONDITIONS	MIN	TYP	MAX	UNIT
Power dissipation capacitance	$C_{PD}$	$V_{CC} = 5V, f=1MHz, No load$		11		pF

■ TEST CIRCUIT AND WAVEFORMS

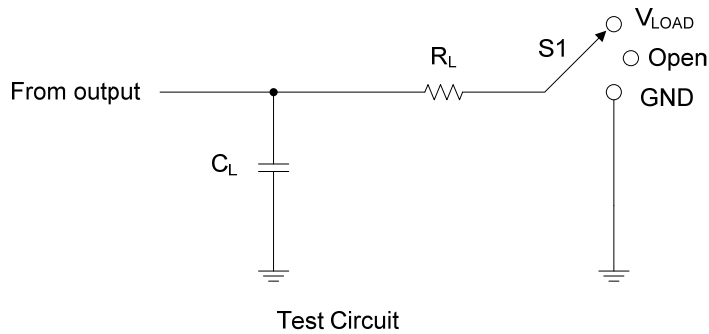

TEST	S
$t_{PLH}/t_{PHL}$	Open
$t_{PLZ}/t_{PZL}$	$V_{LOAD}$
$t_{PHZ}/t_{PZH}$	GND

$V_{CC}$	Input		$V_M$	$V_{LOAD}$	$C_L$	$R_L$	$V_{\Delta}$
	$V_{IN}$	$t_R, t_F$					
$3.3V \pm 0.3V$	$V_{CC}$	$\leq 3ns$	$V_{CC}/2$	$V_{CC}$	15pF	1k $\Omega$	0.3V
					50pF		
$5V \pm 0.5V$	$V_{CC}$	$\leq 3ns$	$V_{CC}/2$	$V_{CC}$	15pF	1k $\Omega$	0.5V
					50pF		

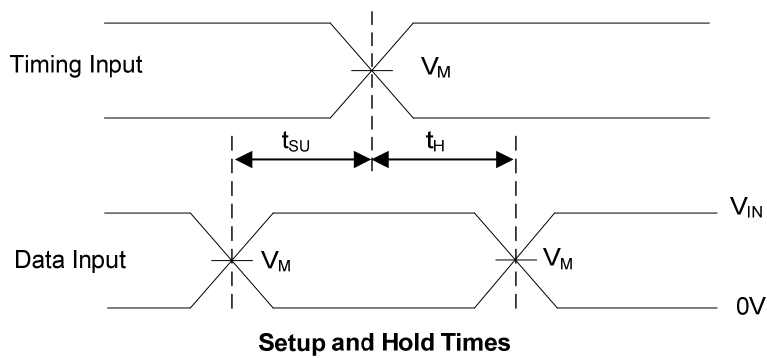
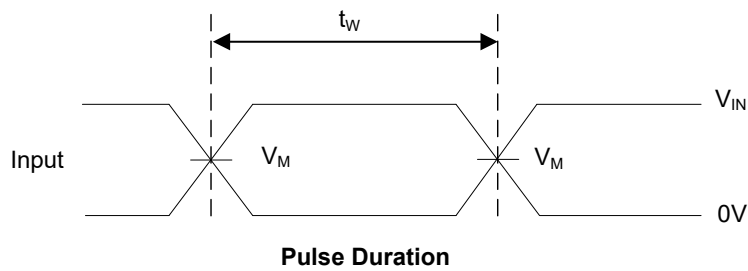

■ TEST CIRCUIT AND WAVEFORMS (Cont.)

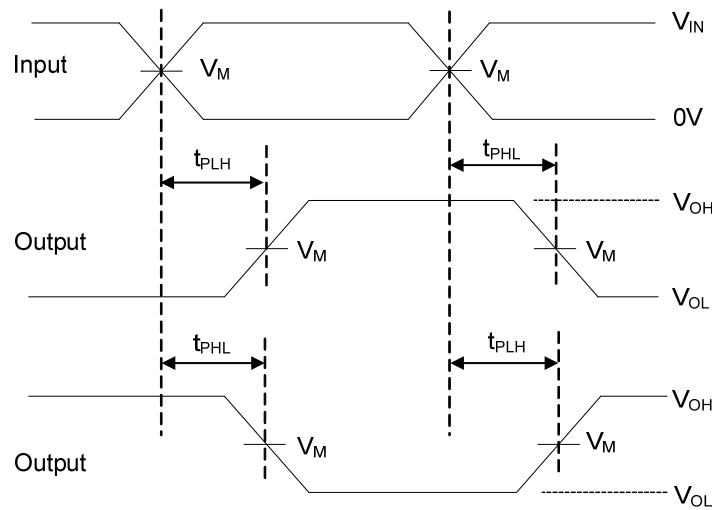

**Voltage Waveforms Propagation Delay Times**

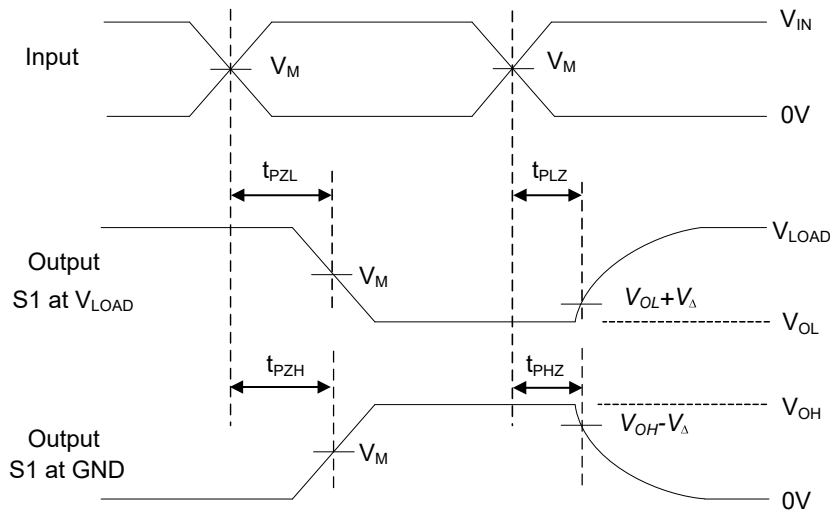

**Voltage Waveforms Enable and Disable Times**

Notes: 1.  $C_L$  includes probe and jig capacitance.

2. All input pulses are supplied by generators having the following characteristics: PRR  $\leq$  1MHz,  $Z_O = 50\Omega$ ,  $t_R \leq 3ns$ ,  $t_F \leq 3ns$ .

UTC assumes no responsibility for equipment failures that result from using products at values that exceed, even momentarily, rated values (such as maximum ratings, operating condition ranges, or other parameters) listed in products specifications of any and all UTC products described or contained herein. UTC products are not designed for use in life support appliances, devices or systems where malfunction of these products can be reasonably expected to result in personal injury. Reproduction in whole or in part is prohibited without the prior written consent of the copyright owner. UTC reserves the right to make changes to information published in this document, including without limitation specifications and product descriptions, at any time and without notice. This document supersedes and replaces all information supplied prior to the publication hereof.