



PBL01NBT-C0

LIGHT EMITTING DIODE

BLUE HIGH POWER LED

■ **FEATURES**

- * Very long operating life
- * Energy efficient

■ **APPLICATIONS**

- * Automotive exterior and interior lighting
- * Architectural lighting
- * Electronic signs and signals

■ **MECHANICAL DIMENSIONS**

Note:Dimensions shown in mm

Dome Type

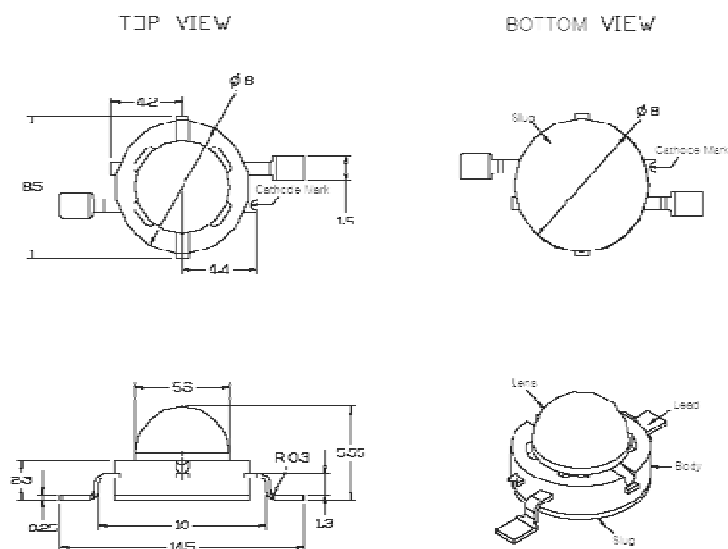

■ ORDERING INFORMATION

Ordering Number
PBL01NBT-C0

<p>P B L 0 1 N B T - C 0</p> <p>(1)View Angle (2)Lead Frame (3)Lens Type (4)Base Type (5)Watts (6)Color Type (7)Product Type</p>	<p>(1) C0: 120° (2) T: Round (3) B: Helmet (4) N: No Al Base (5) 01: 1w (6) BL: Blue (7) P: Power LED</p>
--	---

■ ABSOLUTE MAXIMUM RATINGS (Ta=25)

PARAMETER	SYMBOL	RATINGS	UNIT
DC Forward Current	I _F	350	mA
Forward Pulse Current (Note1)	I _{FP}	500	mA
Reverse Voltage	V _R	5	V
Viewing Angle	2θ _{1/2}	120	°
Operation Temperature	T _{OPR}	-40 ~ +80	
Storage Temperature	T _{STG}	-40 ~ +80	

Note: 1. Pulse width 0.1msec max. Duty cycle1/10

2. Absolute maximum ratings are those values beyond which the device could be permanently damaged. Absolute maximum ratings are stress ratings only and functional device operation is not implied.

■ ELECTRICAL CHARACTERISTICS

PARAMETER	SYMBOL	TEST CONDITIONS	MIN	TYP	MAX	UNIT
Luminous Flux	L _x	I _F =350mA	6	8		lm
Forward Voltage	V _F	I _F =350mA	3.1	3.4	3.8	V
Reverse Current	I _R	V _R =5V			10	uA
Dominant Wavelength	λ _D	I _F =350mA	460	465	470	nm
Viewing Angle	2θ _{1/2}	I _F =350mA		120		°

■ RELIABILITY ITEMS AND CONDITIONS

NO.	ITEMS	TEST CONDITIONS	NOTE	RESULT
1	Resistance to Soldering Heat	260 ±5	10Sec.	Pass
2	Thermal Shock	-20 ~ 100 10Min. 5Sec. 10Min.	50Cycles	Pass
3	Temperature Cycle	-40 25 100 30Min. 5Min. 30Min.	100Cycles	Pass
4	Hi-Temp. Storage	100	1000Hrs	Pass
5	Low-Temp. Storage	-40	1000Hrs	Pass
6	Hi-Temperature/ Hi-Humidity Test	60 /90%RH	1000Hrs	Pass
7	Operating Life	I _F =350mA	1000Hrs	Pass
8	Life Time 1	500mA@ROOM TEMP	1000Hrs	Pass
9	Life Time 2	350mA@-40	1000Hrs	Pass
10	ON/OFF Test	IF=700mA Pulse width 0.1msec max. Duty cycle1/10	100,000 Cycles	Pass

TYPICAL CHARACTERISTICS

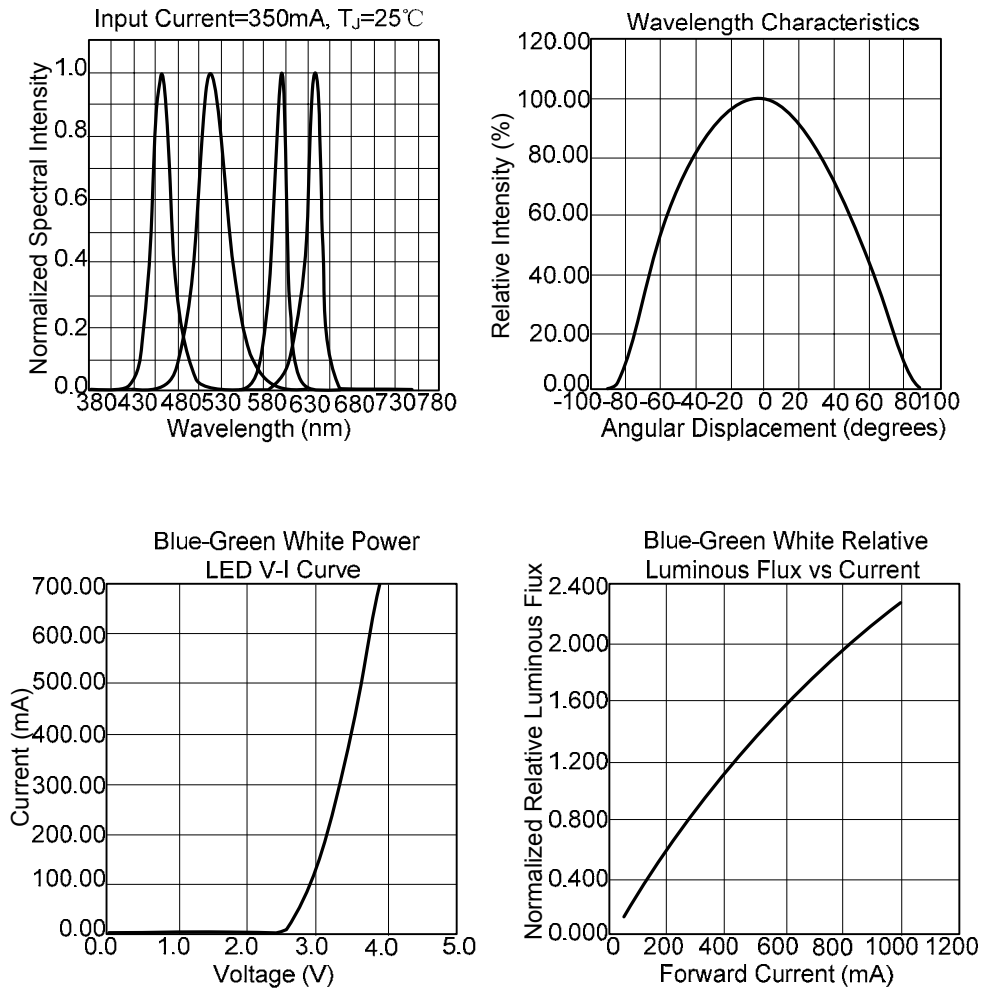

UTC assumes no responsibility for equipment failures that result from using products at values that exceed, even momentarily, rated values (such as maximum ratings, operating condition ranges, or other parameters) listed in products specifications of any and all UTC products described or contained herein. UTC products are not designed for use in life support appliances, devices or systems where malfunction of these products can be reasonably expected to result in personal injury. Reproduction in whole or in part is prohibited without the prior written consent of the copyright owner. The information presented in this document does not form part of any quotation or contract, is believed to be accurate and reliable and may be changed without notice.