



MMBF170

Power MOSFET

0.5A, 60V N-CHANNEL ENHANCEMENT MODE FIELD EFFECT TRANSISTOR

DESCRIPTION

The UTC **MMBF170** is an N-channel enhancement MOSFET using UTC's advanced technology to provide the customers with perfect $R_{DS(ON)}$, low input capacitance, low gate threshold voltage and high switching speed.

FEATURES

- * $R_{DS(ON)} \leq 5.0 \Omega$ @ $V_{GS}=10V, I_D=0.2A$
- * High Switching Speed
- * Low Input Capacitance (typical 22pF)

SYMBOL

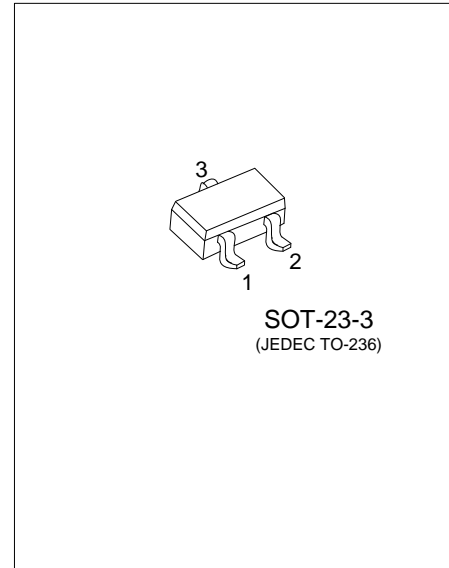
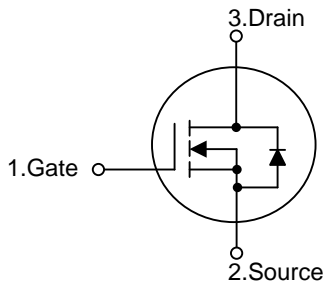

ORDERING INFORMATION

Ordering Number		Package	Pin Assignment			Packing
Lead Free	Halogen Free		1	2	3	
MMBF170L-AE2-R	MMBF170G-AE2-R	SOT-23-3	G	S	D	Tape Reel

Note: Pin Assignment: G: Gate S: Source D: Drain

<p>MMBF170G-AE2-R</p> <p>(1) Packing Type</p> <p>(2) Package Type</p> <p>(3) Green Package</p>	<p>(1) R: Tape Reel</p> <p>(2) AE2: SOT-23-3</p> <p>(3) G: Halogen Free and Lead Free, L: Lead Free</p>
--	---

MARKING

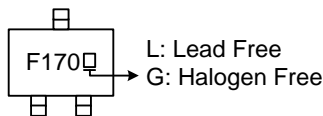

■ ABSOLUTE MAXIMUM RATINGS (T_A=25°C, unless otherwise specified)

PARAMETER	SYMBOL	RATINGS	UNIT
Drain-Source Voltage	V _{DSS}	60	V
Gate-Source Voltage	Continuous	±20	V
	Pulsed	±40	V
Drain-Gate Voltage R _{GS} ≤ 1.0MΩ	V _{DGR}	60	V
Drain Current (Note 2)	Continuous	I _D	500 mA
	Pulsed	I _{DM}	800 mA
Power Dissipation (Note 2)	P _D	225	mW
Derating above T _A =25°C (Note 2)		1.80	mW/°C
Junction Temperature	T _J	+150	°C
Storage Temperature	T _{STG}	-55 ~ +150	°C

Notes: 1. Absolute maximum ratings are those values beyond which the device could be permanently damaged. Absolute maximum ratings are stress ratings only and functional device operation is not implied.
2. Valid provided that terminals are kept at specified ambient temperature.

■ THERMAL CHARACTERISTICS

PARAMETER	SYMBOL	RATINGS	UNIT
Junction to Ambient	θ _{JA}	556	°C/W

■ ELECTRICAL CHARACTERISTICS (T_A=25°C, unless otherwise specified)

PARAMETER	SYMBOL	TEST CONDITIONS	MIN	TYP	MAX	UNIT
OFF CHARACTERISTICS (Note 1)						
Drain-Source Breakdown Voltage	BV _{DSS}	I _D =100μA, V _{GS} =0V	60	70		V
Drain-Source Leakage Current	I _{DSS}	V _{DS} =60V, V _{GS} =0V			1.0	μA
Gate- Source Leakage Current	I _{GSS}	V _{DS} =0V, V _{GS} =+15V			+10	nA
		V _{DS} =0V, V _{GS} =-15V			-10	nA
ON CHARACTERISTICS (Note 1)						
Gate Threshold Voltage	V _{GS(TH)}	V _{DS} =V _{GS} , I _D =-250μA	0.8	2.1	3.0	V
Static Drain-Source On-State Resistance	R _{DS(ON)}	V _{GS} =10V, I _D =200mA			5.0	Ω
		V _{GS} =4.5V, I _D =50mA			5.3	Ω
Forward Transconductance	g _{FS}	V _{DS} =10V, I _D =0.2A	80			mS
DYNAMIC PARAMETERS						
Input Capacitance	C _{ISS}	V _{GS} =0V, V _{DS} =10V, f=1.0MHz		22	40	pF
Output Capacitance	C _{OSS}			11	30	pF
Reverse Transfer Capacitance	C _{RSS}			2.0	5.0	pF
SWITCHING PARAMETERS						
Turn-ON Delay Time	t _{D(ON)}	V _{DD} =25V, I _D =0.5A, V _{GS} =10V,			10	ns
Turn-OFF Delay Time	t _{D(OFF)}	R _{GEN} =50Ω			10	ns

Notes: 1. Pulse Test : Pulse width ≤ 300μs, Duty cycle ≤ 2%.

UTC assumes no responsibility for equipment failures that result from using products at values that exceed, even momentarily, rated values (such as maximum ratings, operating condition ranges, or other parameters) listed in products specifications of any and all UTC products described or contained herein. UTC products are not designed for use in life support appliances, devices or systems where malfunction of these products can be reasonably expected to result in personal injury. Reproduction in whole or in part is prohibited without the prior written consent of the copyright owner. UTC reserves the right to make changes to information published in this document, including without limitation specifications and product descriptions, at any time and without notice. This document supersedes and replaces all information supplied prior to the publication hereof.