



12N65

Power MOSFET

12A, 650V N-CHANNEL POWER MOSFET

DESCRIPTION

The UTC **12N65** are N-Channel enhancement mode power field effect transistors (MOSFET) which are produced by using UTC's proprietary, planar stripe and DMOS technology.

These devices are suited for high efficiency switch mode power supply. To minimize on-state resistance, provide superior switching performance and withstand high energy pulse in the avalanche and commutation mode, the advanced technology has been especially tailored.

FEATURES

- * $R_{DS(ON)} \leq 0.85 \Omega @ V_{GS} = 10V, I_D = 6.0A$
- * Ultra low gate charge (typical 42 nC)
- * Low reverse transfer capacitance ($C_{RSS} =$ typical 25 pF)
- * Fast switching capability
- * Avalanche energy specified
- * Improved dv/dt capability, high ruggedness

SYMBOL

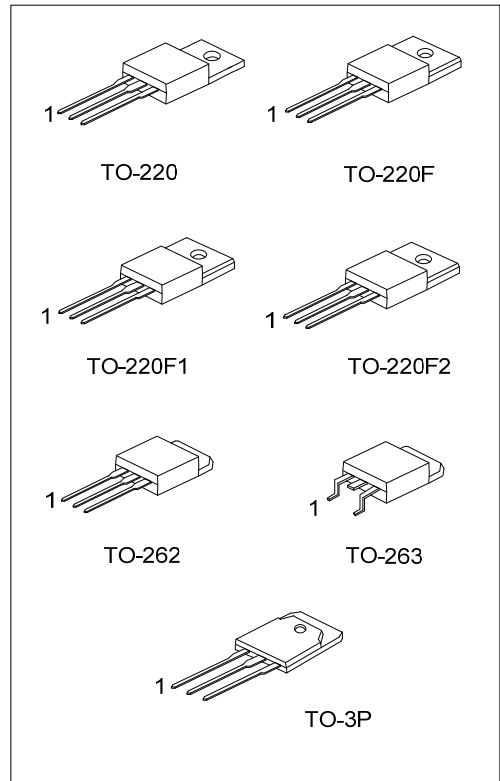
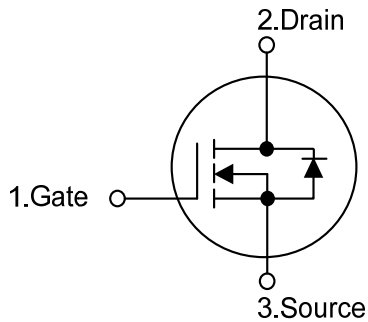

■ ORDERING INFORMATION

Ordering Number		Package	Pin Assignment			Packing
Lead Free	Halogen Free		1	2	3	
12N65L-TA3-T	12N65G-TA3-T	TO-220	G	D	S	Tube
12N65L-TF1-T	12N65G-TF1-T	TO-220F1	G	D	S	Tube
12N65L-TF2-T	12N65G-TF2-T	TO-220F2	G	D	S	Tube
12N65L-TF3-T	12N65G-TF3-T	TO-220F	G	D	S	Tube
12N65L-T2Q-T	12N65G-T2Q-T	TO-262	G	D	S	Tube
12N65L-TQ2-T	12N65G-TQ2-T	TO-263	G	D	S	Tube
12N65L-TQ2-R	12N65G-TQ2-R	TO-263	G	D	S	Tape Reel
12N65L-T3P-T	12N65G-T3P-T	TO-3P	G	D	S	Tube

Note: Pin Assignment: G: Gate D: Drain S: Source

<p>12N65G-TA3-T</p>	<p>(1) T: Tube, R: Tape Reel (2) TA3: TO-220, TF1: TO-220F1, TF2: TO-220F2 TF3: TO-220F, T2Q: TO-262, TQ2: TO-263 T3P: TO-3P (3) G: Halogen Free and Lead Free, L: Lead Free</p>
---------------------	--

■ MARKING

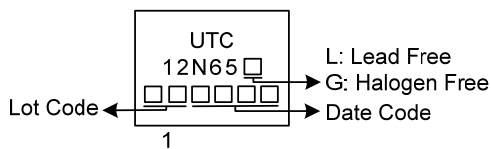

■ ABSOLUTE MAXIMUM RATINGS ($T_C = 25^\circ\text{C}$, unless otherwise specified)

PARAMETER		SYMBOL	RATINGS	UNIT
Drain-Source Voltage		V_{DSS}	650	V
Gate-Source Voltage		V_{GSS}	± 30	V
Avalanche Current (Note 2)		I_{AR}	12	A
Drain Current	Continuous	I_D	12	A
	Pulsed (Note 2)	I_{DM}	48	A
Avalanche Energy	Single Pulsed (Note 3)	E_{AS}	790	mJ
	Repetitive (Note 2)	E_{AR}	24	mJ
Peak Diode Recovery dv/dt (Note 4)		dv/dt	4.5	V/ns
Power Dissipation	TO-220/TO-262 TO-263	P_D	225	W
	TO-220F/TO-220F1		51	W
	TO-220F2		54	W
	TO-3P		260	W
Junction Temperature		T_J	+150	$^\circ\text{C}$
Operating Temperature		T_{OPR}	-55 ~ +150	$^\circ\text{C}$
Storage Temperature		T_{STG}	-55 ~ +150	$^\circ\text{C}$

Notes: 1. Absolute maximum ratings are those values beyond which the device could be permanently damaged.

Absolute maximum ratings are stress ratings only and functional device operation is not implied.

2. Repetitive Rating : Pulse width limited by maximum junction temperature.

3. $L = 10\text{mH}$, $I_{AS} = 12\text{A}$, $V_{DD} = 50\text{V}$, $R_G = 25\Omega$, Starting $T_J = 25^\circ\text{C}$

4. $I_{SD} \leq 12\text{A}$, $di/dt \leq 200\text{A/s}$, $V_{DD} \leq BV_{DSS}$ Starting $T_J = 25^\circ\text{C}$

■ THERMAL DATA

PARAMETER		SYMBOL	RATING	UNIT
Junction to Ambient	TO-220/TO-220F TO-220F1/TO-220F2 TO-262/TO-263	θ_{JA}	62.5	$^\circ\text{C/W}$
	TO-3P		40	$^\circ\text{C/W}$
	Junction to Case		θ_{JC}	0.56
TO-220/TO-262 TO-263	2.43	$^\circ\text{C/W}$		
TO-220F/TO-220F1	2.31	$^\circ\text{C/W}$		
TO-220F2	0.48	$^\circ\text{C/W}$		
TO-3P				

■ ELECTRICAL CHARACTERISTICS (T_C = 25°C, unless otherwise specified)

PARAMETER	SYMBOL	TEST CONDITIONS	MIN	TYP	MAX	UNIT
OFF CHARACTERISTICS						
Drain-Source Breakdown Voltage	BV _{DSS}	V _{GS} = 0 V, I _D = 250 μA	650			V
Drain-Source Leakage Current	I _{DSS}	V _{DS} = 650 V, V _{GS} = 0 V			1	μA
Gate-Source Leakage Current	I _{GSS}	V _{GS} = ±30 V, V _{DS} = 0 V			±100	nA
Breakdown Voltage Temperature Coefficient	ΔBV _{DSS} /ΔT _J	I _D = 250 μA, Referenced to 25°C		0.7		V/°C
ON CHARACTERISTICS						
Gate Threshold Voltage	V _{GS(TH)}	V _{DS} = V _{GS} , I _D = 250 μA	2.0		4.0	V
Static Drain-Source On-State Resistance	R _{DS(ON)}	V _{GS} = 10V, I _D = 6.0A		0.65	0.85	Ω
DYNAMIC CHARACTERISTICS						
Input Capacitance	C _{ISS}	V _{DS} = 25 V, V _{GS} = 0 V, f = 1MHz		1480	1900	pF
Output Capacitance	C _{OSS}			200	270	pF
Reverse Transfer Capacitance	C _{RSS}			25	35	pF
SWITCHING CHARACTERISTICS						
Total Gate Charge	Q _G	V _{DS} = 520V, I _D = 12A, V _{GS} = 10 V (Note 1, 2)		42	54	nC
Gate-Source Charge	Q _{GS}			8.6		nC
Gate-Drain Charge	Q _{GD}			21		nC
Turn-On Delay Time	t _{D(ON)}	V _{DD} = 325V, I _D = 12A, R _G = 25Ω (Note 1, 2)		30	70	ns
Turn-On Rise Time	t _R			115	240	ns
Turn-Off Delay Time	t _{D(OFF)}			95	200	ns
Turn-Off Fall Time	t _F			85	180	ns
SOURCE- DRAIN DIODE RATINGS AND CHARACTERISTICS						
Maximum Continuous Drain-Source Diode Forward Current	I _S				12	A
Maximum Pulsed Drain-Source Diode Forward Current	I _{SM}				48	A
Drain-Source Diode Forward Voltage	V _{SD}	V _{GS} = 0 V, I _S = 12A			1.4	V
Reverse Recovery Time	t _{rr}	V _{GS} = 0 V, I _S = 12A, dI _F /dt = 100 A/μs (Note 1)		380		ns
Reverse Recovery Charge	Q _{rr}			3.5		μC

Notes: 1. Pulse Test : Pulse width ≤ 300 μs, Duty cycle ≤ 2%

2. Essentially independent of operating temperature

■ TEST CIRCUITS AND WAVEFORMS

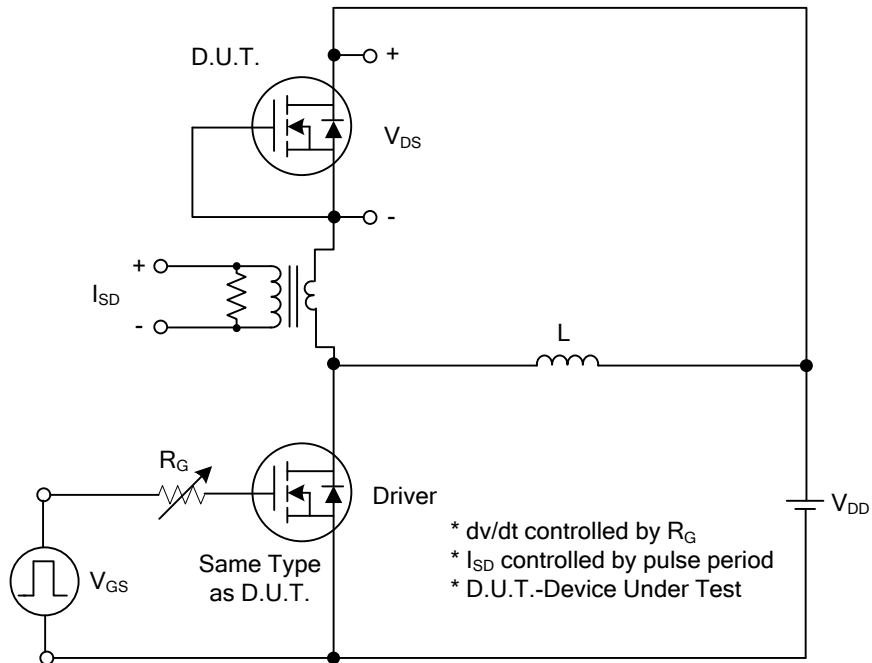

Peak Diode Recovery dv/dt Test Circuit

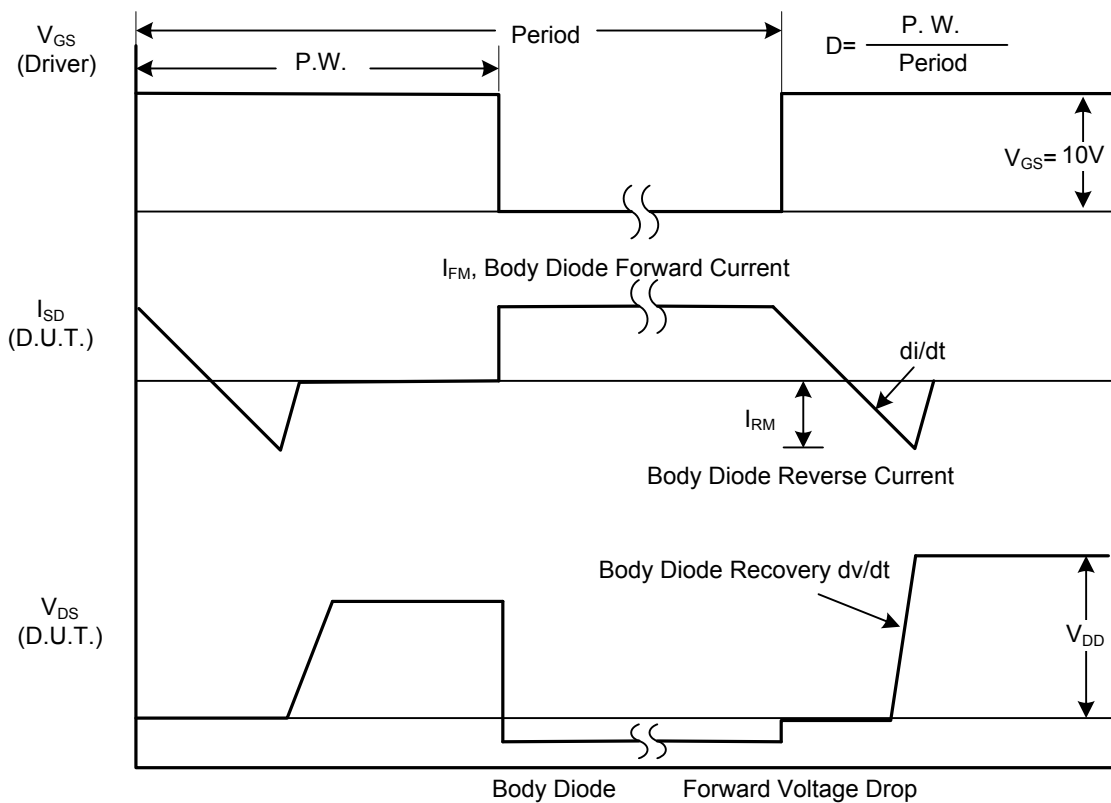

Peak Diode Recovery dv/dt Waveforms

TEST CIRCUITS AND WAVEFORMS

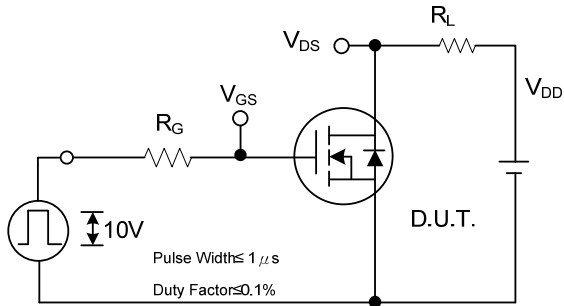

Switching Test Circuit

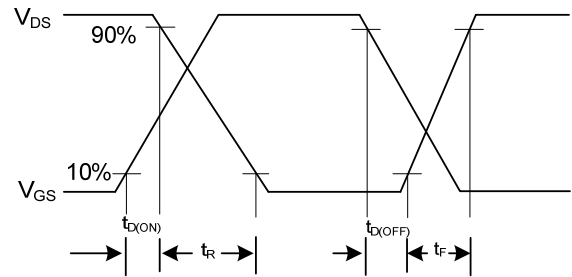

Switching Waveforms

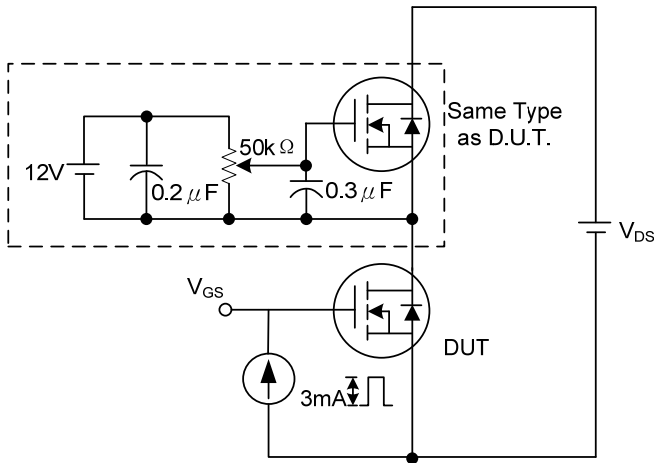

Gate Charge Test Circuit

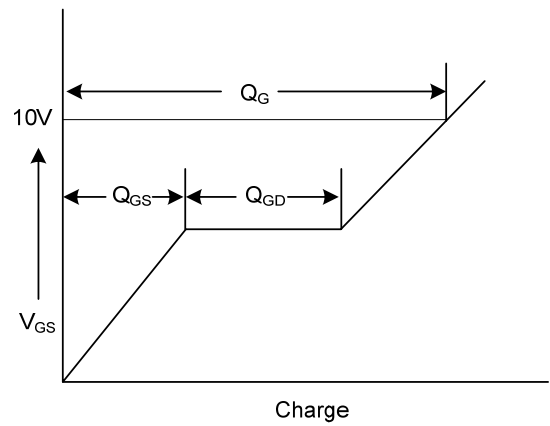

Gate Charge Waveform

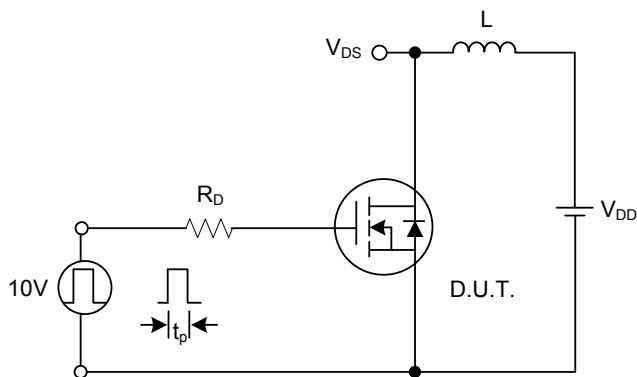

Unclamped Inductive Switching Test Circuit

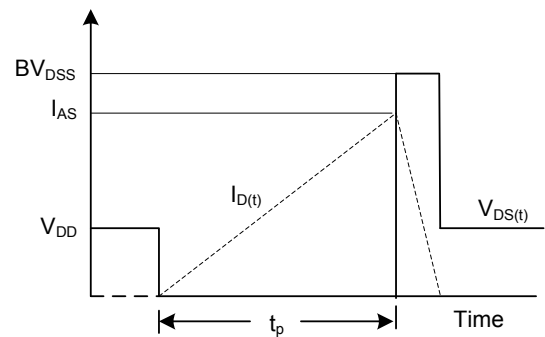

Unclamped Inductive Switching Waveforms

TYPICAL CHARACTERISTICS

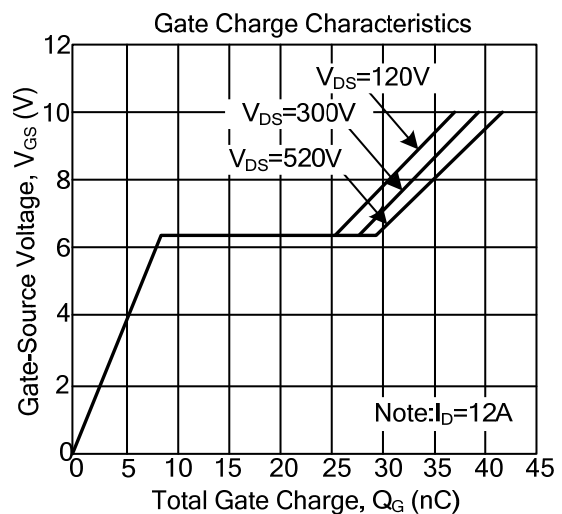
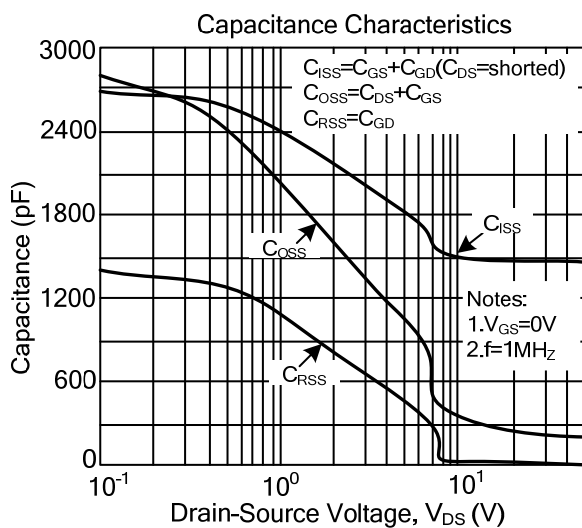
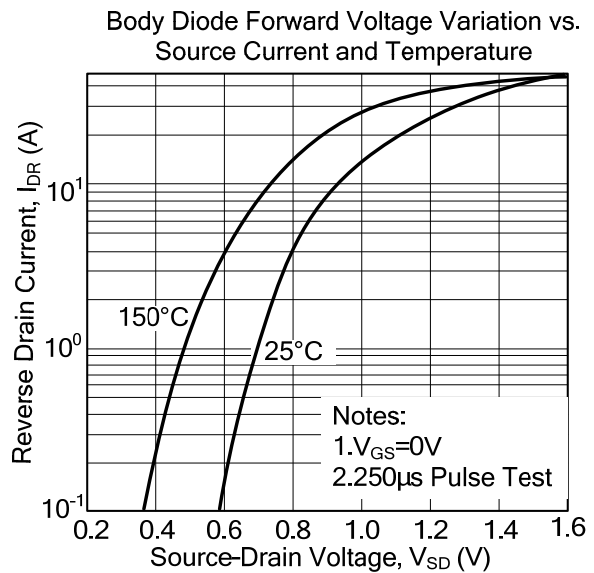
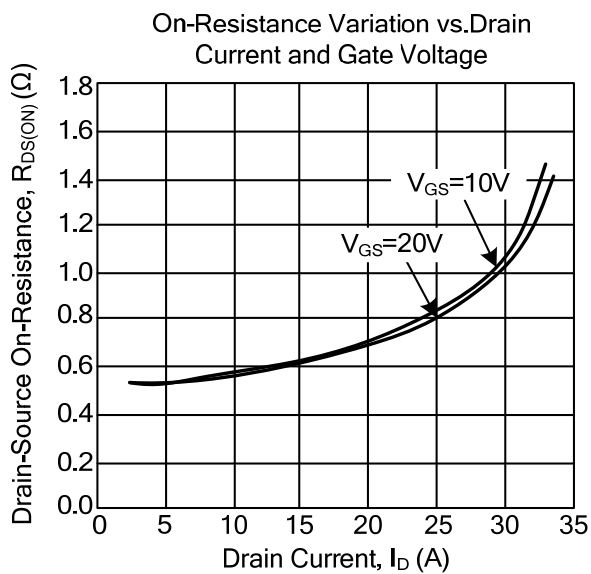
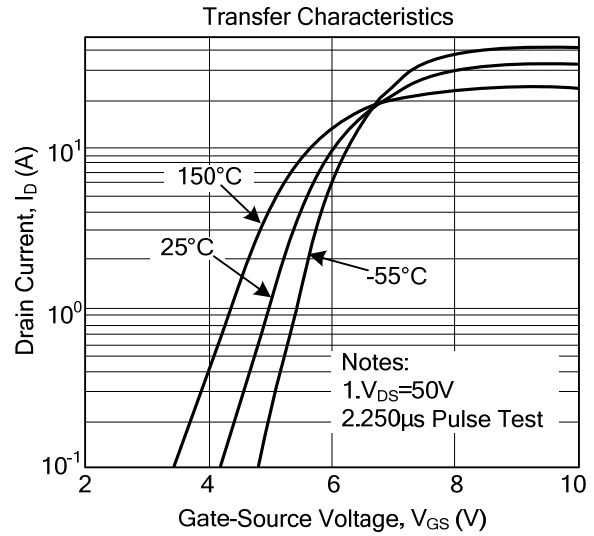
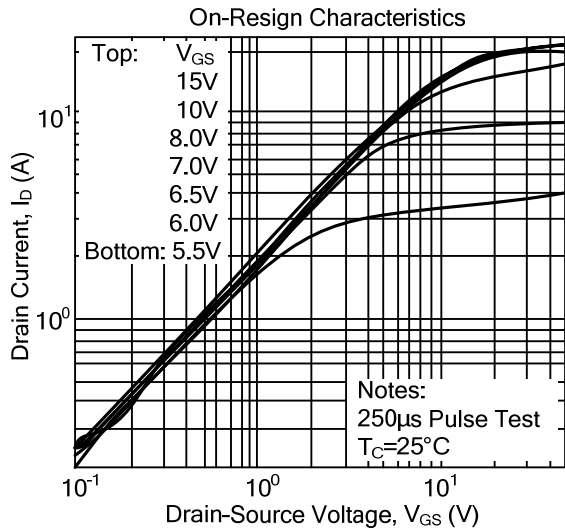

■ TYPICAL CHARACTERISTICS

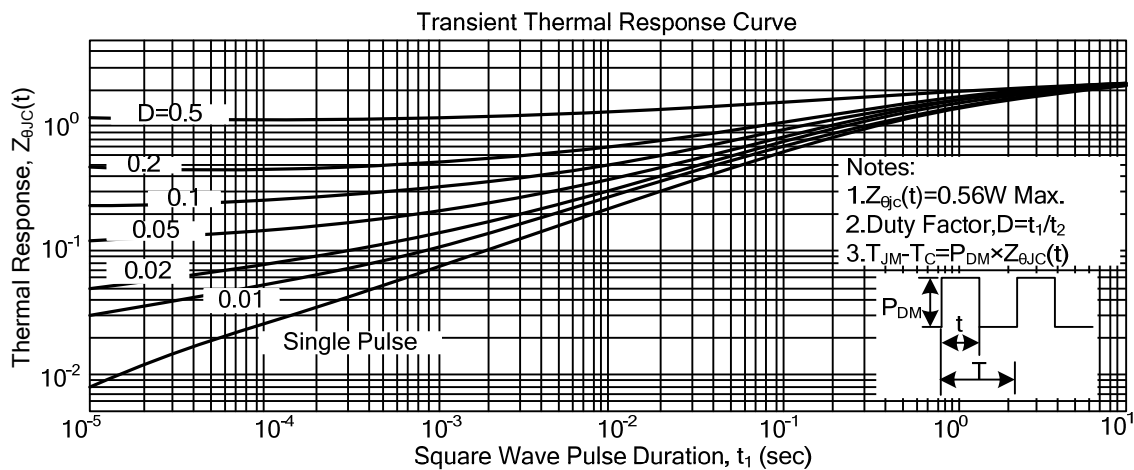
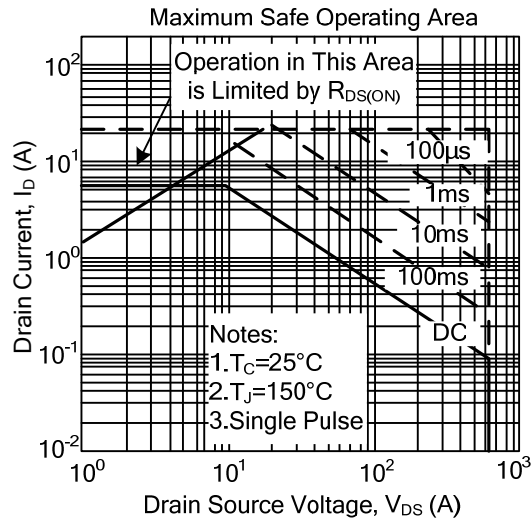

UTC assumes no responsibility for equipment failures that result from using products at values that exceed, even momentarily, rated values (such as maximum ratings, operating condition ranges, or other parameters) listed in products specifications of any and all UTC products described or contained herein. UTC products are not designed for use in life support appliances, devices or systems where malfunction of these products can be reasonably expected to result in personal injury. Reproduction in whole or in part is prohibited without the prior written consent of the copyright owner. UTC reserves the right to make changes to information published in this document, including without limitation specifications and product descriptions, at any time and without notice. This document supersedes and replaces all information supplied prior to the publication hereof.