



2N65L

Power MOSFET

2A, 650V N-CHANNEL POWER MOSFET

DESCRIPTION

The UTC **2N65L** is a high voltage power MOSFET and is designed to have better characteristics, such as fast switching time, low gate charge, low on-state resistance and a high rugged avalanche characteristics. This power MOSFET is usually used in the high speed switching applications of power supplies, PWM motor controls, high efficient DC to DC converters and bridge circuits.

FEATURES

- * $R_{DS(ON)} < 5.0\Omega @ V_{GS} = 10V, I_D = 1A$
- * Ultra Low gate charge (typical 9.0nC)
- * Low reverse transfer capacitance ($C_{RSS} = \text{typical } 5.0 \text{ pF}$)
- * Fast switching capability
- * Avalanche energy specified
- * Improved dv/dt capability, high ruggedness

SYMBOL

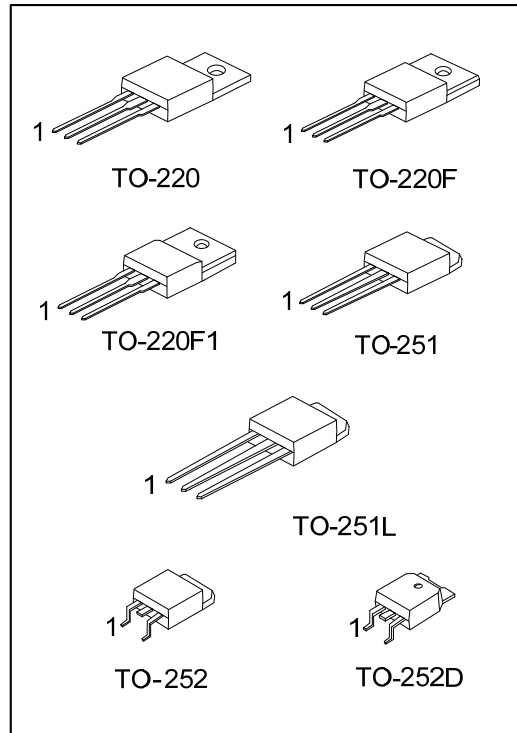
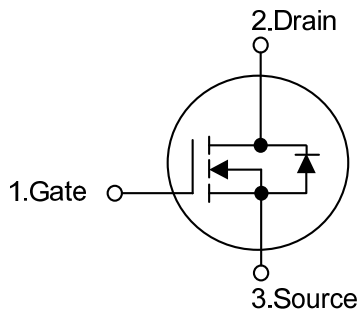

ORDERING INFORMATION

Ordering Number		Package	Pin Assignment			Packing
Lead Free	Halogen Free		1	2	3	
2N65LL-TA3-T	2N65LG-TA3-T	TO-220	G	D	S	Tube
2N65LL-TF1-T	2N65LG-TF1-T	TO-220F1	G	D	S	Tube
2N65LL-TF3-T	2N65LG-TF3-T	TO-220F	G	D	S	Tube
2N65LL-TM3-T	2N65LG-TM3-T	TO-251	G	D	S	Tube
2N65LL-TMA-T	2N65LG-TMA-T	TO-251L	G	D	S	Tube
2N65LL-TN3-R	2N65LG-TN3-R	TO-252	G	D	S	Tape Reel
2N65LL-TND-R	2N65LG-TND-R	TO-252	G	D	S	Tape Reel

Note: Pin Assignment: G: Gate D: Drain S: Source

<p>2N65LL-TA3-T</p> <p>(1)Packing Type (2)Package Type (3)Green Package</p>	<p>(1) T: Tube, R: Tape Reel (2) TA3: TO-220, TF1: TO-220F1, TF3: TO-220F TM3: TO-251, TMA:TO-251L, TN3: TO-252, TND: TO-252D, T2Q: TO-262 (3) L: Lead Free, G: Halogen Free and Lead Free</p>
---	--

MARKING

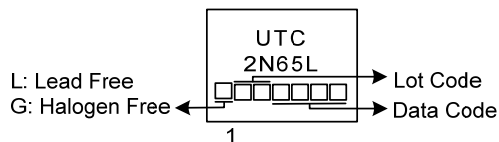

■ ABSOLUTE MAXIMUM RATINGS ($T_C = 25^\circ\text{C}$, unless otherwise specified)

PARAMETER		SYMBOL	RATINGS	UNIT
Drain-Source Voltage		V_{DSS}	650	V
Gate-Source Voltage		V_{GSS}	± 30	V
Avalanche Current (Note 2)		I_{AR}	2.0	A
Drain Current	Continuous	I_D	2.0	A
	Pulsed (Note 2)	I_{DM}	8.0	A
Avalanche Energy	Single Pulsed (Note 3)	E_{AS}	140	mJ
	Repetitive (Note 2)	E_{AR}	4.5	mJ
Peak Diode Recovery dv/dt (Note 4)		dv/dt	4.5	V/ns
Power Dissipation	TO-220	P_D	54	W
	TO-220F/TO-220F1		23	W
	TO-251/TO-251L/TO-252		44	W
	TO-252D			
Junction Temperature		T_J	+150	$^\circ\text{C}$
Operating Temperature		T_{OPR}	-55 ~ +150	$^\circ\text{C}$
Storage Temperature		T_{STG}	-55 ~ +150	$^\circ\text{C}$

Notes: 1. Absolute maximum ratings are those values beyond which the device could be permanently damaged.

Absolute maximum ratings are stress ratings only and functional device operation is not implied.

2. Repetitive Rating : Pulse width limited by T_J

3. $L=64\text{mH}$, $I_{AS}=2.0\text{A}$, $V_{DD}=50\text{V}$, $R_G=25\ \Omega$, Starting $T_J = 25^\circ\text{C}$

4. $I_{SD}\leq 2.4\text{A}$, $di/dt\leq 200\text{A}/\mu\text{s}$, $V_{DD}\leq BV_{DSS}$, Starting $T_J = 25^\circ\text{C}$

■ THERMAL DATA

PARAMETER		SYMBOL	RATINGS	UNIT
Junction to Ambient	TO-220/TO-220F/TO-220F1	θ_{JA}	62.5	$^\circ\text{C}/\text{W}$
	TO-251/TO-251L/TO-252 TO-252D		100	$^\circ\text{C}/\text{W}$
Junction to Case	TO-220	θ_{Jc}	2.32	$^\circ\text{C}/\text{W}$
	TO-220F/TO-220F1		5.5	$^\circ\text{C}/\text{W}$
	TO-251/TO-251L/TO-252		2.87	$^\circ\text{C}/\text{W}$
	TO-252D			

■ ELECTRICAL CHARACTERISTICS ($T_J=25^\circ\text{C}$, unless otherwise specified)

PARAMETER	SYMBOL	TEST CONDITIONS	MIN	TYP	MAX	UNIT
OFF CHARACTERISTICS						
Drain-Source Breakdown Voltage	BV_{DSS}	$V_{GS} = 0V, I_D = 250\mu A$	650			V
Drain-Source Leakage Current	I_{DSS}	$V_{DS} = 650V, V_{GS} = 0V$			10	μA
Gate-Source Leakage Current	Forward	I_{GSS}			100	nA
	Reverse				-100	nA
Breakdown Voltage Temperature Coefficient	$\Delta BV_{DSS}/\Delta T_J$	$I_D=250\mu A$, Referenced to 25°C		0.4		$V/^\circ\text{C}$
ON CHARACTERISTICS						
Gate Threshold Voltage	$V_{GS(TH)}$	$V_{DS} = V_{GS}, I_D = 250\mu A$	2.0		4.0	V
Static Drain-Source On-State Resistance	$R_{DS(ON)}$	$V_{GS} = 10V, I_D = 1A$		3.9	5.0	Ω
DYNAMIC CHARACTERISTICS						
Input Capacitance	C_{ISS}	$V_{DS} = 25V, V_{GS} = 0V,$ $f = 1\text{MHz}$		270	350	pF
Output Capacitance	C_{OSS}		40	50	pF	
Reverse Transfer Capacitance	C_{RSS}		5	7	pF	
SWITCHING CHARACTERISTICS						
Turn-On Delay Time	$t_{D(ON)}$	$V_{DD} = 325V, I_D = 2.4A,$ $R_G = 25\Omega$ (Note 1, 2)		10	30	ns
Turn-On Rise Time	t_R		25	60	ns	
Turn-Off Delay Time	$t_{D(OFF)}$		20	50	ns	
Turn-Off Fall Time	t_F		25	60	ns	
Total Gate Charge	Q_G	$V_{DS} = 520V, V_{GS} = 10V,$ $I_D = 2.4A$ (Note 1, 2)		9.0	11	nC
Gate-Source Charge	Q_{GS}		1.6		nC	
Gate-Drain Charge	Q_{GD}		4.3		nC	
DRAIN-SOURCE DIODE CHARACTERISTICS						
Drain-Source Diode Forward Voltage	V_{SD}	$V_{GS} = 0V, I_{SD} = 2.0A$			1.4	V
Continuous Drain-Source Current	I_{SD}				2.0	A
Pulsed Drain-Source Current	I_{SM}				8.0	A
Reverse Recovery Time	t_{rr}	$V_{GS} = 0V, I_{SD} = 2.4A,$ $di/dt = 100A/\mu s$ (Note1)		180		ns
Reverse Recovery Charge	Q_{RR}		0.72		μC	

Notes: 1. Pulse Test: Pulse width $\leq 300\mu s$, Duty cycle $\leq 2\%$

2. Essentially independent of operating temperature

■ TEST CIRCUITS AND WAVEFORMS

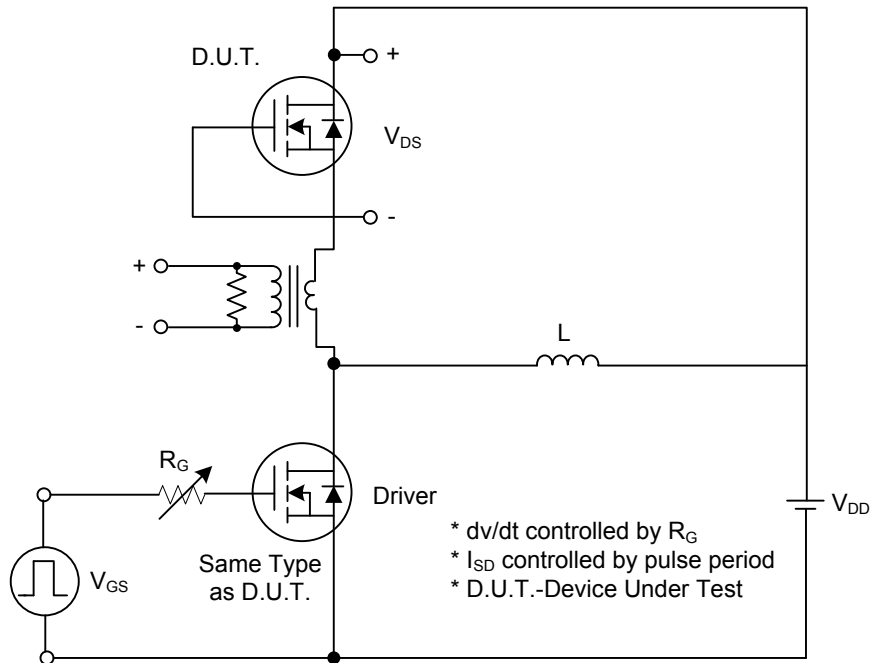

Peak Diode Recovery dv/dt Test Circuit

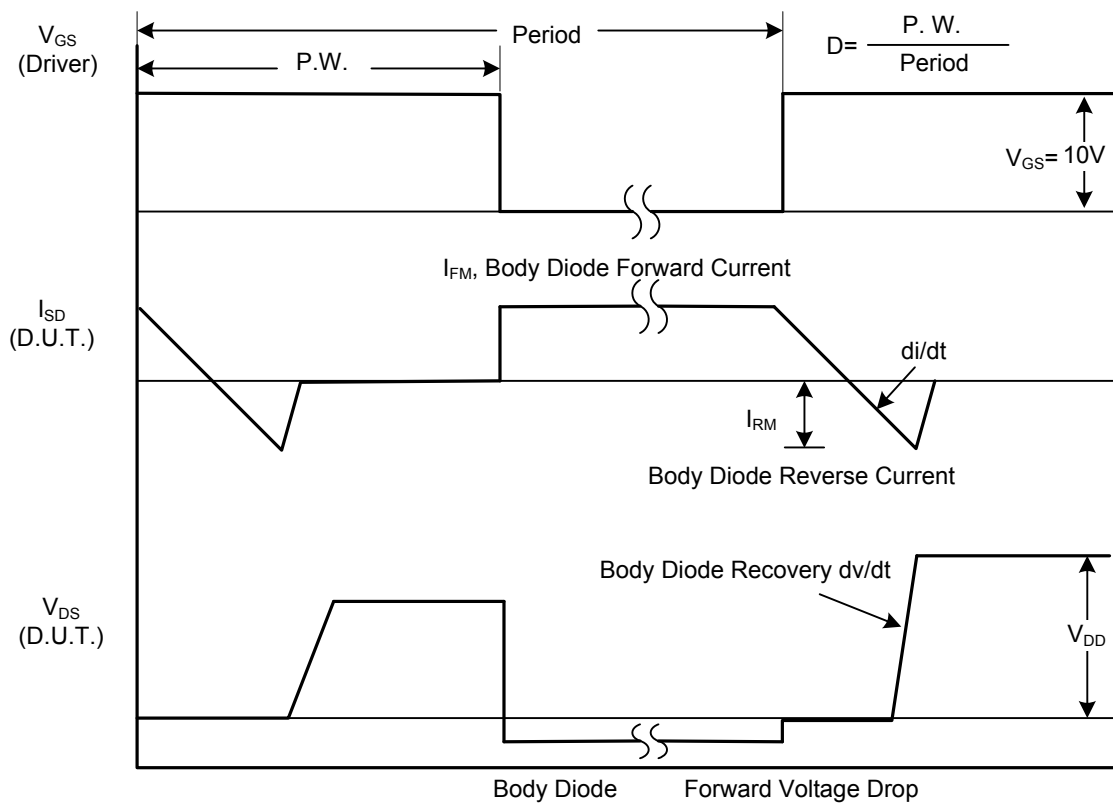

Peak Diode Recovery dv/dt Waveforms

■ TEST CIRCUITS AND WAVEFORMS (Cont.)

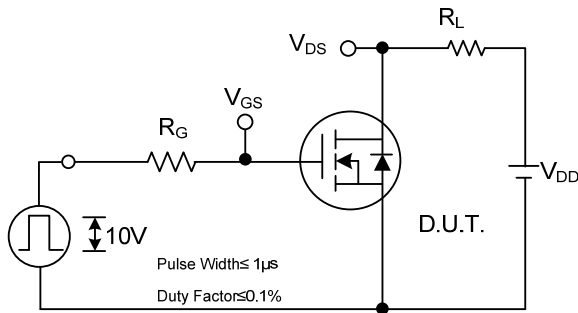

Switching Test Circuit



Switching Waveforms

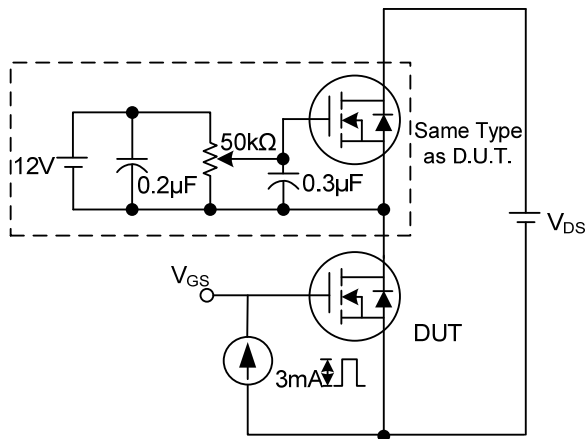

Gate Charge Test Circuit



Gate Charge Waveform

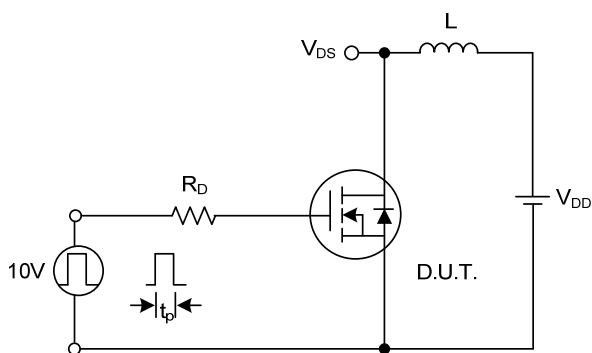

Unclamped Inductive Switching Test Circuit

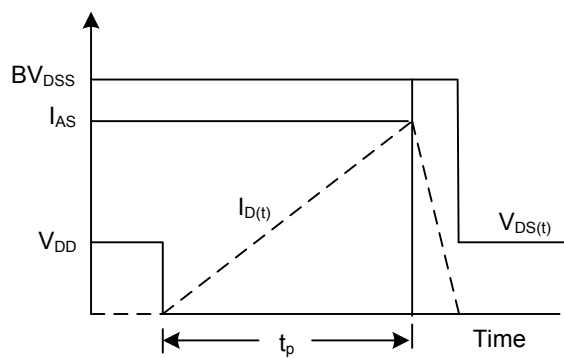

Unclamped Inductive Switching Waveforms

TYPICAL CHARACTERISTICS

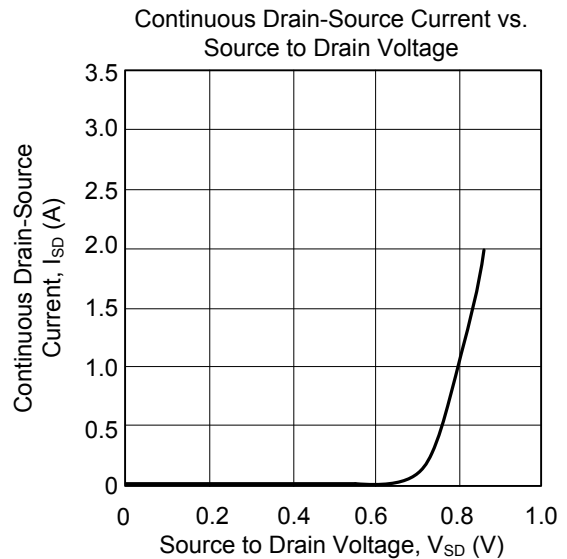
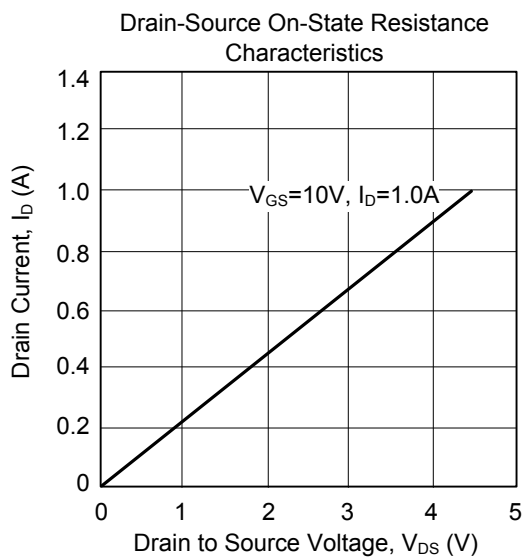
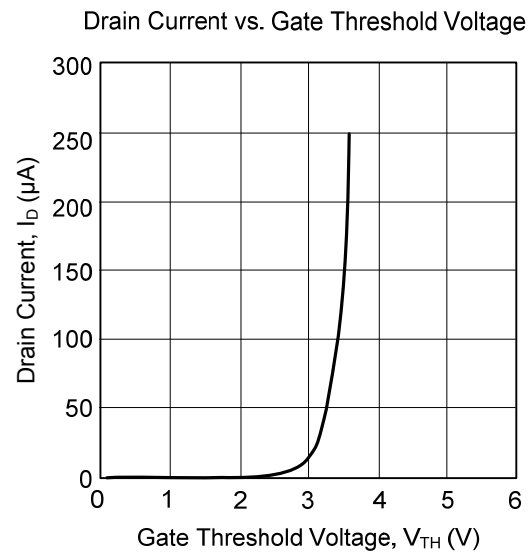
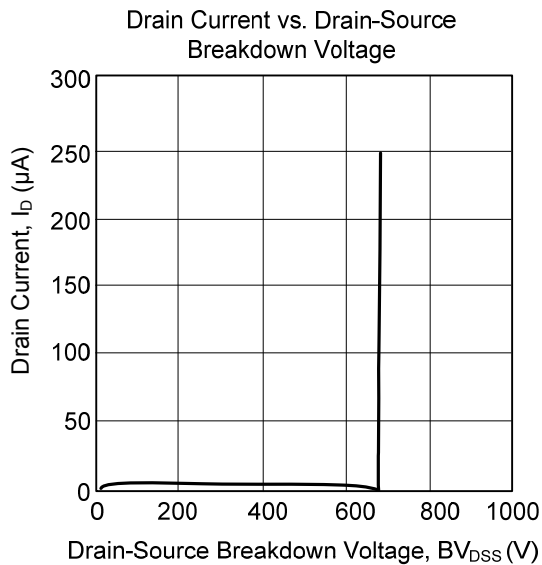

UTC assumes no responsibility for equipment failures that result from using products at values that exceed, even momentarily, rated values (such as maximum ratings, operating condition ranges, or other parameters) listed in products specifications of any and all UTC products described or contained herein. UTC products are not designed for use in life support appliances, devices or systems where malfunction of these products can be reasonably expected to result in personal injury. Reproduction in whole or in part is prohibited without the prior written consent of the copyright owner. The information presented in this document does not form part of any quotation or contract, is believed to be accurate and reliable and may be changed without notice.