



# UF3205

**Power MOSFET**

## 110A, 55V N-CHANNEL POWER MOSFET

■ DESCRIPTION

The UTC **UF3205** uses advanced technology to provide excellent  $R_{DS(ON)}$ , fast switching, low gate charge, and extremely efficient. This device is suitable for all commercial-industrial applications at power dissipation levels to approximately 50 watts.

■ FEATURES

- \*  $R_{DS(ON)} \leq 8.0 \text{ m}\Omega @ V_{GS}=10V, I_D=62A$
- \* Ultra Low Gate Charge ( 146nC max )
- \* Low Reverse Transfer Capacitance (  $C_{RSS} = \text{typ. } 211 \text{ pF}$  )
- \* Fast Switching Capability
- \* Avalanche Energy Specified
- \* Improved dv/dt Capability, High Ruggedness

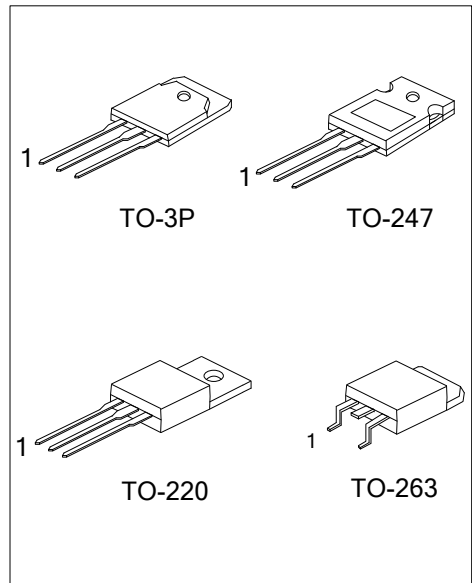

■ SYMBOL

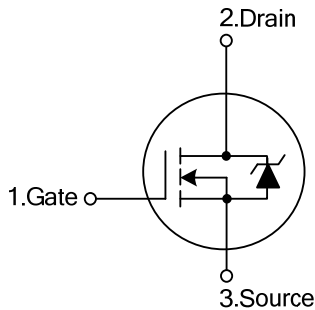

■ ORDERING INFORMATION

Ordering Number		Package	Pin Assignment			Packing
Lead Free	Halogen Free		1	2	3	
UF3205L-TA3-T	UF3205G-TA3-T	TO-220	G	D	S	Tube
UF3205L-T3P-T	UF3205G-T3P-T	TO-3P	G	D	S	Tube
UF3205L-T47-T	UF3205G-T47-T	TO-247	G	D	S	Tube
UF3205L-TQ2-T	UF3205G-TQ2-T	TO-263	G	D	S	Tube
UF3205L-TQ2-R	UF3205G-TQ2-R	TO-263	G	D	S	Tape Reel

Note: Pin Assignment: G: Gate D: Drain S: Source

<p>UF3205G-TA3-T</p> <p>(1)Packing Type (2)Package Type (3)Green Package</p>	<p>(1) T: Tube, R: Tape Reel (2) TA3: TO-220, T3P: TO-3P, T47: TO-247, TQ2: TO-263 (3) G: Halogen Free and Lead Free, L: Lead Free</p>
--	--

MARKING

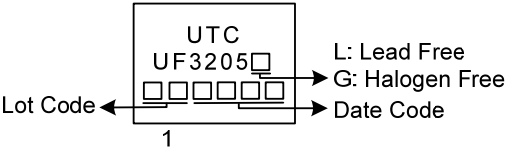

### ■ ABSOLUTE MAXIMUM RATINGS

PARAMETER		SYMBOL	RATINGS	UNIT
Gate-Source Voltage		$V_{GSS}$	±20	V
Drain-Source Voltage		$V_{DSS}$	55	V
Drain Current	Continuous ( $V_{GS}=10V$ )	$I_D$	110	A
	Pulsed (Note 2)	$I_{DM}$	390	
Avalanche Current (Note 2)		$I_{AR}$	62	A
Avalanche Energy	Repetitive(Note 2)	$E_{AR}$	20	mJ
	Single Pulsed(Note 3)	$E_{AS}$	415	
Power Dissipation ( $T_C=25^{\circ}C$ )	TO-220/TO-263	$P_D$	156	W
	TO-3P		362	W
	TO-247		331	W
Junction Temperature		$T_J$	+150	$^{\circ}C$
Storage Temperature		$T_{STG}$	-55 ~ +150	$^{\circ}C$

Notes: 1. Absolute maximum ratings are those values beyond which the device could be permanently damaged.

Absolute maximum ratings are stress ratings only and functional device operation is not implied.

2. Repetitive Rating : Pulse width limited by maximum junction temperature.

3.  $L=0.13mH$ ,  $I_{AS}=62A$ ,  $V_{DD}=50V$ ,  $R_G=25\Omega$ , Starting  $T_J=25^{\circ}C$ .

### ■ THERMAL DATA

PARAMETER		SYMBOL	RATINGS	UNIT
Junction to Ambient	TO-220/TO-263	$\theta_{JA}$	62.5	$^{\circ}C/W$
	TO-3P		30	
	TO-247		40	
Junction to Case	TO-220	$\theta_{JC}$	0.8	$^{\circ}C/W$
	TO-3P		0.35	
	TO-247		0.38	
	TO-263		0.7	

■ ELECTRICAL CHARACTERISTICS (T<sub>J</sub> = 25°C, unless otherwise specified)

PARAMETER	SYMBOL	TEST CONDITIONS	MIN	TYP	MAX	UNIT
<b>OFF CHARACTERISTICS</b>						
Drain-Source Breakdown Voltage	BV <sub>DSS</sub>	V <sub>GS</sub> =0V, I <sub>D</sub> =250μA	55			V
Drain-Source Leakage Current	I <sub>DSS</sub>	V <sub>DS</sub> =55V, V <sub>GS</sub> =0V			25	μA
Gate-Source Leakage Current	I <sub>GSS</sub>	V <sub>GS</sub> =±20V, V <sub>DS</sub> =0V			±100	nA
Breakdown Voltage Temperature Coefficient	ΔBV <sub>DSS</sub> /ΔT <sub>J</sub>	Reference to 25°C, I <sub>D</sub> =1mA		0.057		V/°C
<b>ON CHARACTERISTICS</b>						
Gate Threshold Voltage	V <sub>GS(TH)</sub>	V <sub>DS</sub> =V <sub>GS</sub> , I <sub>D</sub> =250μA	2.0		4.0	V
Static Drain-Source On-Resistance (Note)	R <sub>DS(ON)</sub>	V <sub>GS</sub> =10V, I <sub>D</sub> =62A			8.0	mΩ
<b>DYNAMIC PARAMETERS</b>						
Input Capacitance	C <sub>ISS</sub>	V <sub>DS</sub> =25V, V <sub>GS</sub> =0V, f=1MHz		5100		pF
Output Capacitance	C <sub>OSS</sub>			1000		pF
Reverse Transfer Capacitance	C <sub>RSS</sub>			210		pF
<b>SWITCHING PARAMETERS</b>						
Total Gate Charge	Q <sub>G</sub>	V <sub>DS</sub> =44V, V <sub>GS</sub> =10V, I <sub>D</sub> =62A (Note 1, 2)			146	nC
Gate Source Charge	Q <sub>GS</sub>				35	nC
Gate Drain Charge	Q <sub>GD</sub>				54	nC
Turn-ON Delay Time	t <sub>D(ON)</sub>	V <sub>DS</sub> =28V, V <sub>GS</sub> =10V, I <sub>D</sub> =62A, R <sub>G</sub> =4.5Ω (Note 1, 2)		14		ns
Turn-ON Rise Time	t <sub>R</sub>			25		ns
Turn-OFF Delay Time	t <sub>D(OFF)</sub>			140		ns
Turn-OFF Fall-Time	t <sub>F</sub>			42		ns
<b>SOURCE- DRAIN DIODE RATINGS AND CHARACTERISTICS</b>						
Maximum Continuous Drain-Source Diode Forward Current	I <sub>S</sub>				110	A
Maximum Pulsed Drain-Source Diode Forward Current	I <sub>SM</sub>				390	A
Diode Forward Voltage	V <sub>SD</sub>	I <sub>S</sub> =62A, V <sub>GS</sub> =0V			1.3	V
Body Diode Reverse Recovery Time	t <sub>rr</sub>	I <sub>F</sub> =30A, dI/dt=100A/μs (Note)		140		ns
Body Diode Reverse Recovery Charge	Q <sub>rr</sub>				740	

Note: Pulse width ≤ 400μs; duty cycle ≤ 2%.

■ TEST CIRCUITS AND WAVEFORMS

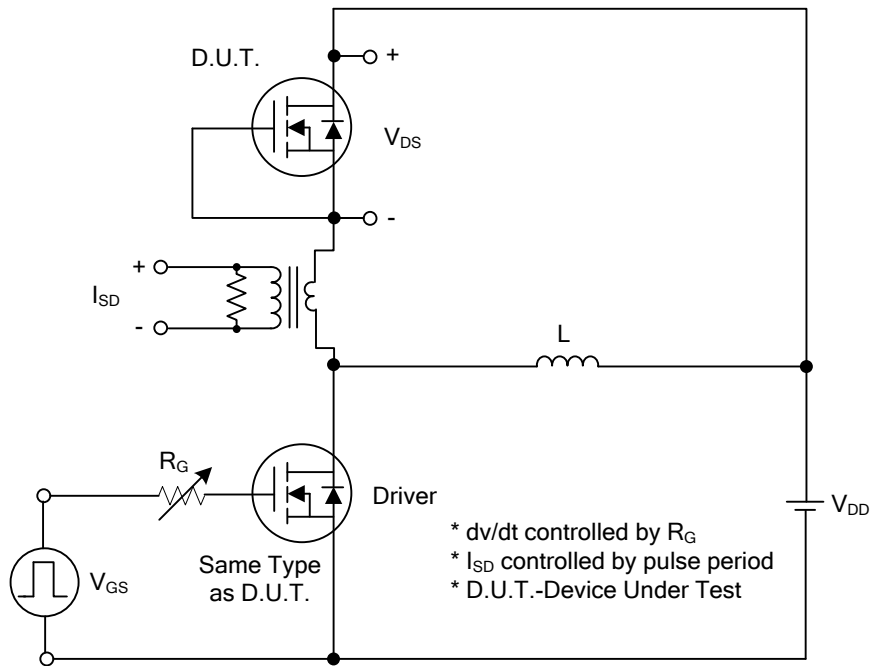

Fig. 1A Peak Diode Recovery dv/dt Test Circuit

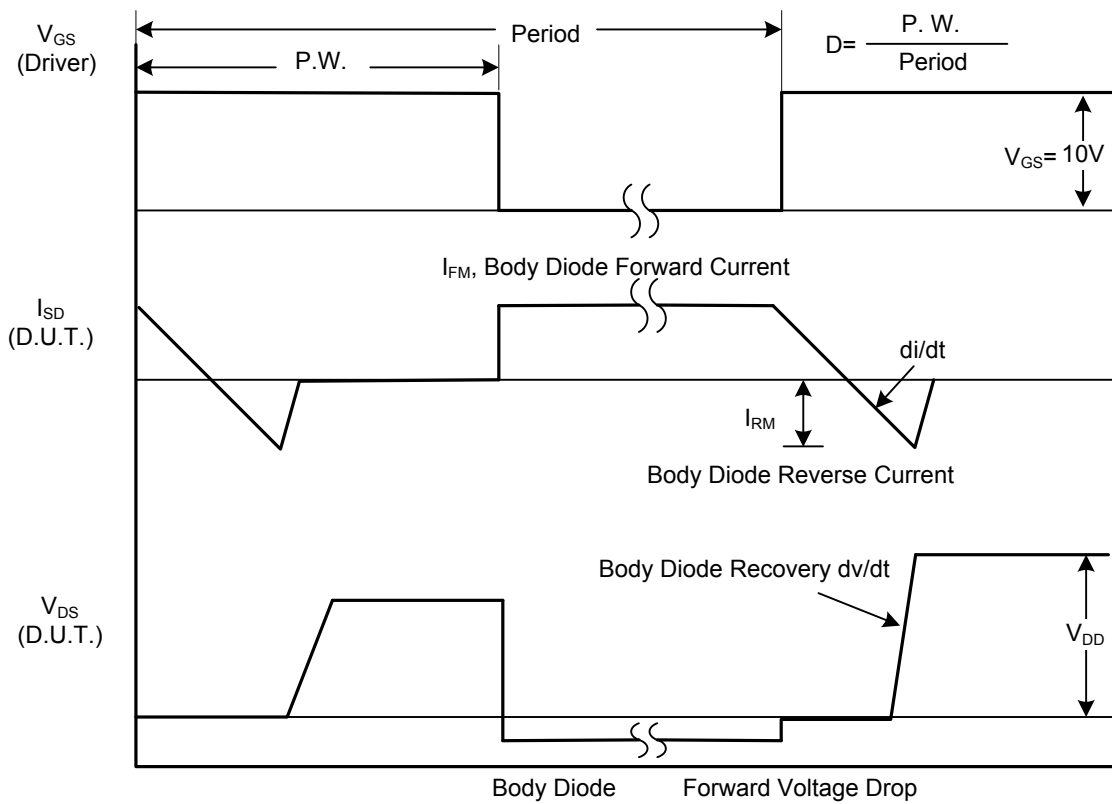
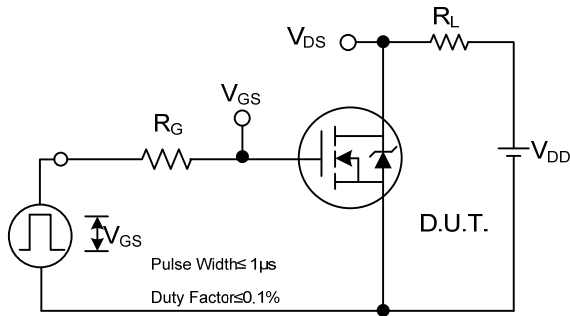
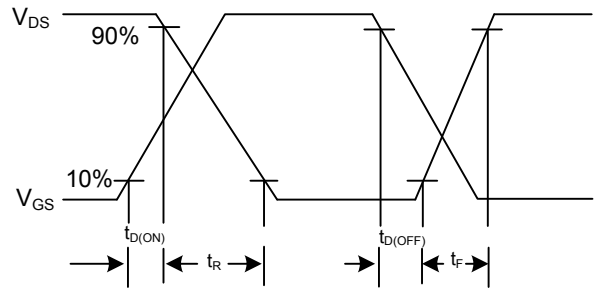

Fig. 1B Peak Diode Recovery dv/dt Waveforms

■ TEST CIRCUITS AND WAVEFORMS



2A Switching Test Circuit



2B Switching Waveforms

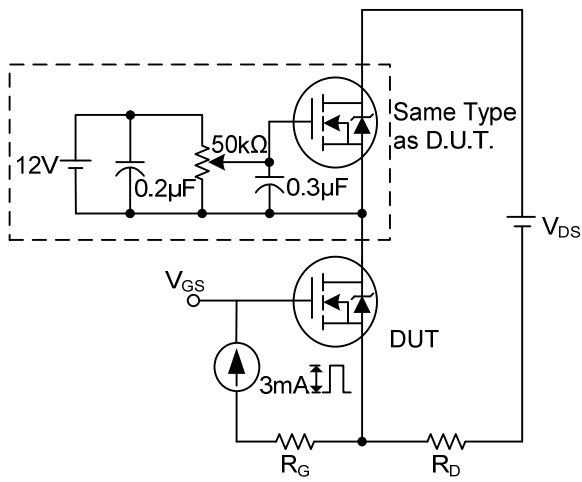

3A Gate Charge Test Circuit

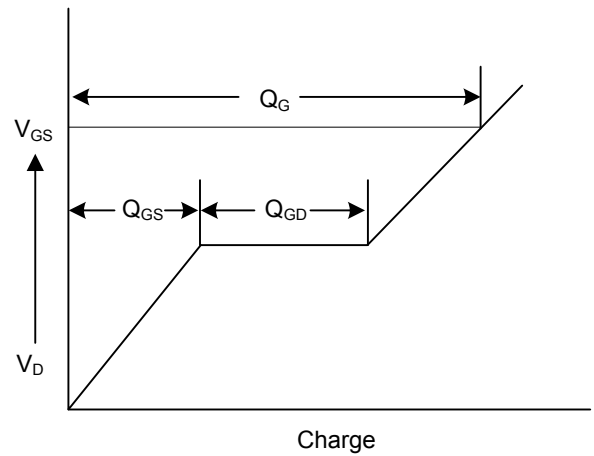

3B Gate Charge Waveform

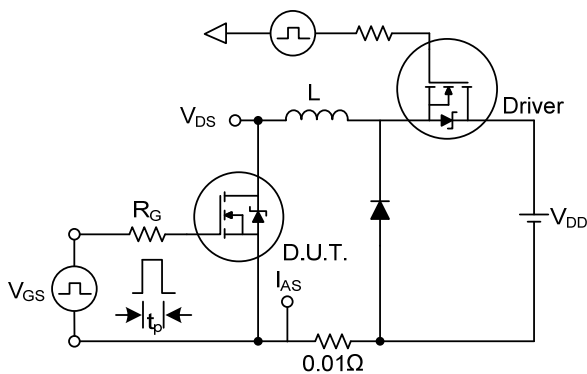

4A Unclamped Inductive Switching Test Circuit

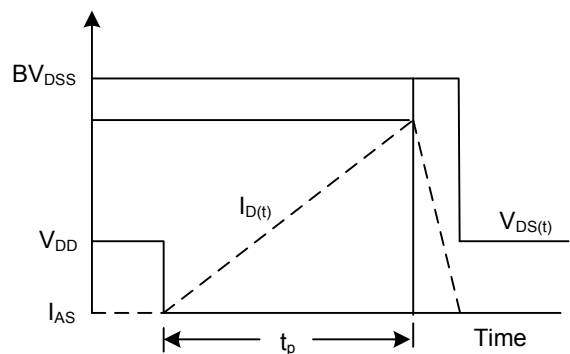

4B Unclamped Inductive Switching Waveforms

■ TYPICAL CHARACTERISTICS

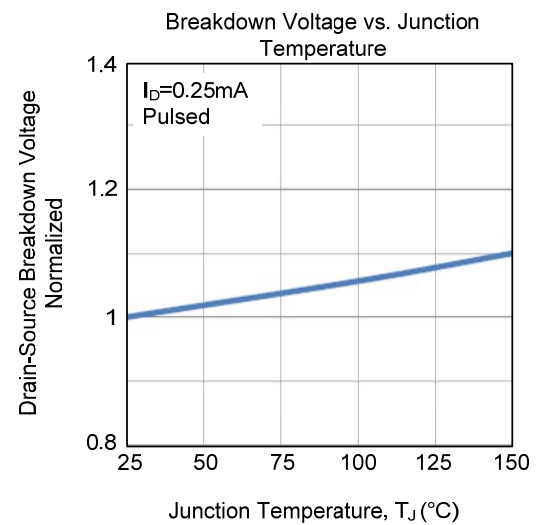
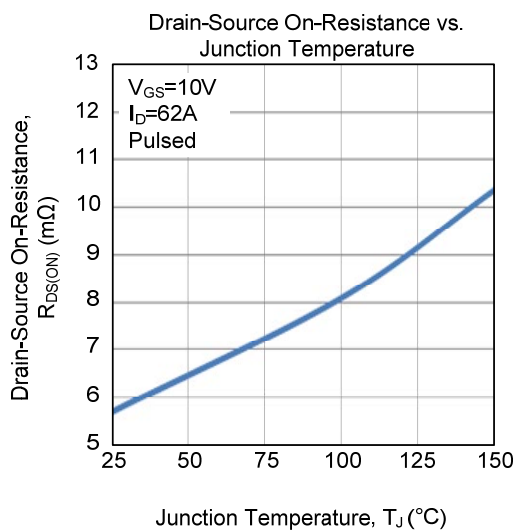
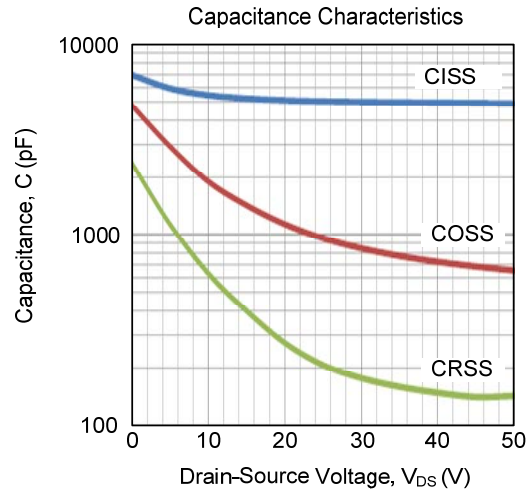
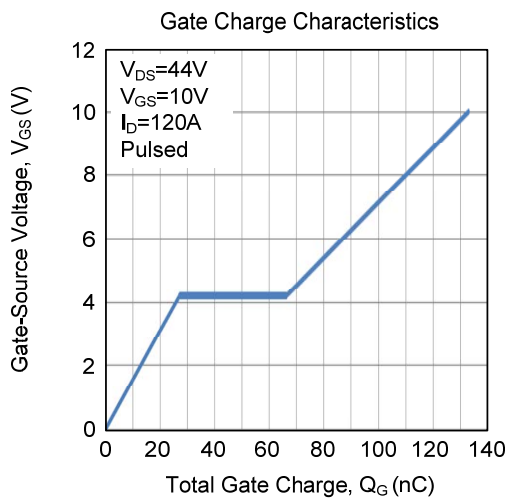
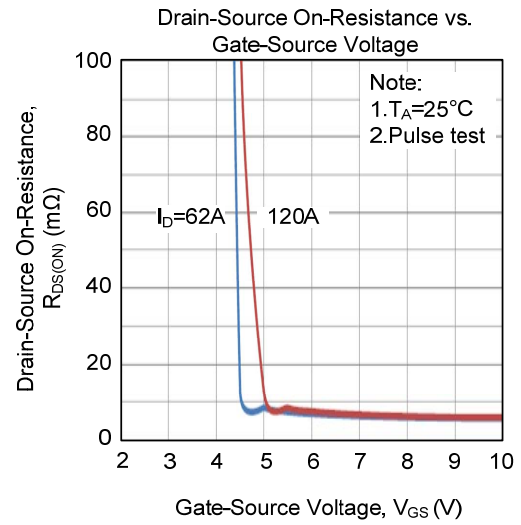
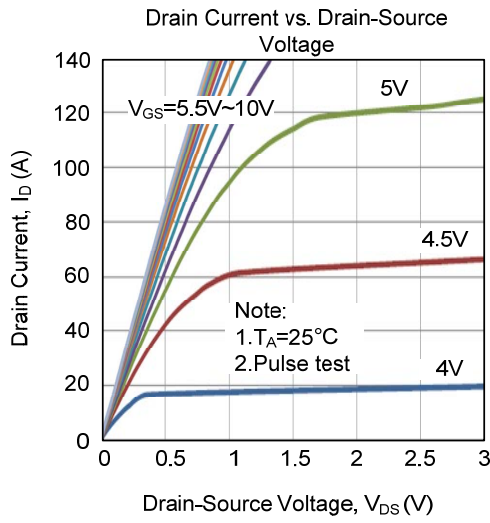

■ TYPICAL CHARACTERISTICS (Cont.)

