



## 7N60Z

Power MOSFET

### 7.4A, 600V N-CHANNEL POWER MOSFET

#### DESCRIPTION

The UTC **7N60Z** is a high voltage power MOSFET designed to have better characteristics, such as fast switching time, low gate charge, low on-state resistance and have a high rugged avalanche characteristics. This power MOSFET is usually used in high speed switching applications of switching power supplies and adaptors.

#### FEATURES

- \*  $R_{DS(ON)} = 1\Omega @ V_{GS} = 10V$
- \* Ultra Low Gate Charge (Typical 29 nC)
- \* Low Reverse Transfer Capacitance (  $C_{RSS} =$  typical 16pF )
- \* Fast Switching Capability
- \* Avalanche Energy Tested
- \* Improved dv/dt Capability, High Ruggedness

#### SYMBOL

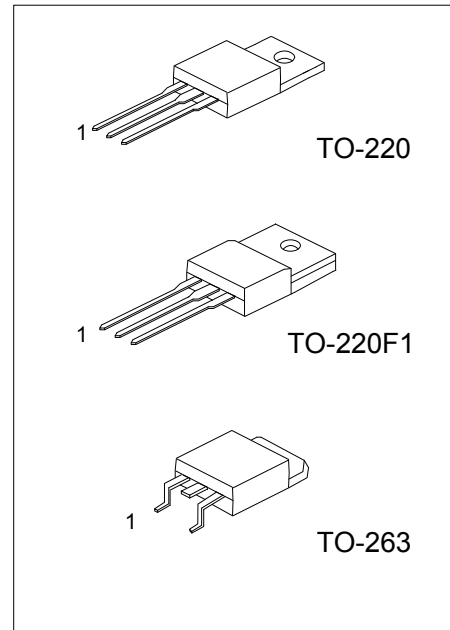
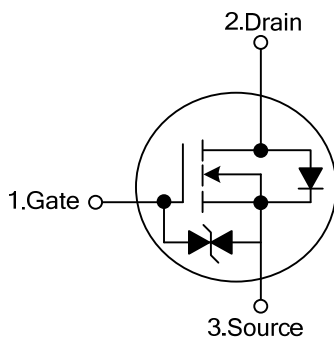

#### ORDERING INFORMATION

Ordering Number		Package	Pin Assignment			Packing
Lead Free	Halogen Free		1	2	3	
7N60ZL-TA3-T	7N60ZG-TA3-T	TO-220	G	D	S	Tube
7N60ZL-TF1-T	7N60ZG-TF1-T	TO-220F1	G	D	S	Tube
7N60ZL-TQ2-T	7N60ZG-TQ2-T	TO-263	G	D	S	Tube
7N60ZL-TQ2-R	7N60ZG-TQ2-R	TO-263	G	D	S	Tape Reel

Note: Pin Assignment: G: Gate D: Drain S: Source

<p>7N60ZL-TA3-T</p> <p>(1) Packing Type</p> <p>(2) Package Type</p> <p>(3) Lead Free</p>	<p>(1) T: Tube, R: Tape Reel</p> <p>(2) TA3: TO-220, TF1: TO-220F1, TQ2: TO-263</p> <p>(3) L: Lead Free, G: Halogen Free</p>
--	--

■ ABSOLUTE MAXIMUM RATINGS ( $T_C = 25^\circ\text{C}$ , unless otherwise specified)

PARAMETER		SYMBOL	RATINGS	UNIT
Drain-Source Voltage		$V_{DSS}$	600	V
Gate-Source Voltage		$V_{GSS}$	$\pm 30$	V
Avalanche Current (Note 2)		$I_{AR}$	7.4	A
Continuous Drain Current		$I_D$	7.4	A
Pulsed Drain Current (Note 1)		$I_{DM}$	29.6	A
Avalanche Energy	Single Pulsed (Note 3)	$E_{AS}$	600	mJ
	Repetitive (Note 2)	$E_{AR}$	14.2	mJ
Peak Diode Recovery dv/dt (Note 4)		dv/dt	4.5	V/ns
Power Dissipation	TO-220/ TO-263	$P_D$	142	W
	TO-220F1		48	W
Junction Temperature		$T_J$	+150	$^\circ\text{C}$
Storage Temperature		$T_{STG}$	-55 ~ +150	$^\circ\text{C}$

Notes: 1. Absolute maximum ratings are those values beyond which the device could be permanently damaged.

Absolute maximum ratings are stress ratings only and functional device operation is not implied.

2. Repetitive Rating : Pulse width limited by maximum junction temperature

3.  $L = 19.5\text{mH}$ ,  $I_{AS} = 7.4\text{A}$ ,  $V_{DD} = 50\text{V}$ ,  $R_G = 25\ \Omega$ , Starting  $T_J = 25^\circ\text{C}$

4.  $I_{SD} \leq 7.4\text{A}$ ,  $di/dt \leq 200\text{A}/\mu\text{s}$ ,  $V_{DD} \leq BV_{DSS}$ , Starting  $T_J = 25^\circ\text{C}$

■ THERMAL DATA

PARAMETER		SYMBOL	RATINGS	UNIT
Junction to Ambient		$\theta_{JA}$	62.5	$^\circ\text{C}/\text{W}$
Junction to Case	TO-220/ TO-263	$\theta_{JC}$	0.88	$^\circ\text{C}/\text{W}$
	TO-220F1		2.6	$^\circ\text{C}/\text{W}$

■ ELECTRICAL CHARACTERISTICS (TC =25°C, unless otherwise specified)

PARAMETER	SYMBOL	TEST CONDITIONS	MIN	TYP	MAX	UNIT
<b>OFF CHARACTERISTICS</b>						
Drain-Source Breakdown Voltage	$BV_{DSS}$	$V_{GS} = 0V, I_D = 250\mu A$	600			V
Drain-Source Leakage Current	$I_{DSS}$	$V_{DS} = 600V, V_{GS} = 0V$			1	$\mu A$
Gate- Source Leakage Current	Forward	$I_{GSS}$			10	$\mu A$
	Reverse				-10	$\mu A$
Breakdown Voltage Temperature Coefficient	$\Delta BV_{DSS}/\Delta T_J$	$I_D = 250\mu A$ , Referenced to 25°C		0.67		V/°C
<b>ON CHARACTERISTICS</b>						
Gate Threshold Voltage	$V_{GS(TH)}$	$V_{DS} = V_{GS}, I_D = 250\mu A$	2.0		4.0	V
Static Drain-Source On-State Resistance	$R_{DS(ON)}$	$V_{GS} = 10V, I_D = 3.7A$		0.83	1	$\Omega$
<b>DYNAMIC CHARACTERISTICS</b>						
Input Capacitance	$C_{ISS}$	$V_{DS} = 25V, V_{GS} = 0V,$ $f = 1.0 \text{ MHz}$			1400	pF
Output Capacitance	$C_{OSS}$				180	pF
Reverse Transfer Capacitance	$C_{RSS}$			16	21	pF
<b>SWITCHING CHARACTERISTICS</b>						
Turn-On Delay Time	$t_{D(ON)}$	$V_{DD} = 300V, I_D = 7.4A,$ $R_G = 25\Omega$ (Note 1, 2)			70	ns
Turn-On Rise Time	$t_R$				170	ns
Turn-Off Delay Time	$t_{D(OFF)}$				140	ns
Turn-Off Fall Time	$t_F$				130	ns
Total Gate Charge	$Q_G$	$V_{DS} = 480V, I_D = 7.4A,$ $V_{GS} = 10V$ (Note 1, 2)		29	38	nC
Gate-Source Charge	$Q_{GS}$			7		nC
Gate-Drain Charge	$Q_{GD}$			14.5		nC
<b>DRAIN-SOURCE DIODE CHARACTERISTICS AND MAXIMUM RATINGS</b>						
Drain-Source Diode Forward Voltage	$V_{SD}$	$V_{GS} = 0V, I_S = 7.4A$			1.4	V
Maximum Continuous Drain-Source Diode Forward Current	$I_S$				7.4	A
Maximum Pulsed Drain-Source Diode Forward Current	$I_{SM}$				29.6	A
Reverse Recovery Time	$t_{rr}$	$V_{GS} = 0V, I_S = 7.4A,$		320		ns
Reverse Recovery Charge	$Q_{RR}$	$di_F / dt = 100A/\mu s$ (Note 1)		2.4		$\mu C$

Notes: 1. Pulse Test: Pulse width  $\leq 300\mu s$ , Duty cycle  $\leq 2\%$

2. Essentially independent of operating temperature

■ TEST CIRCUITS AND WAVEFORMS

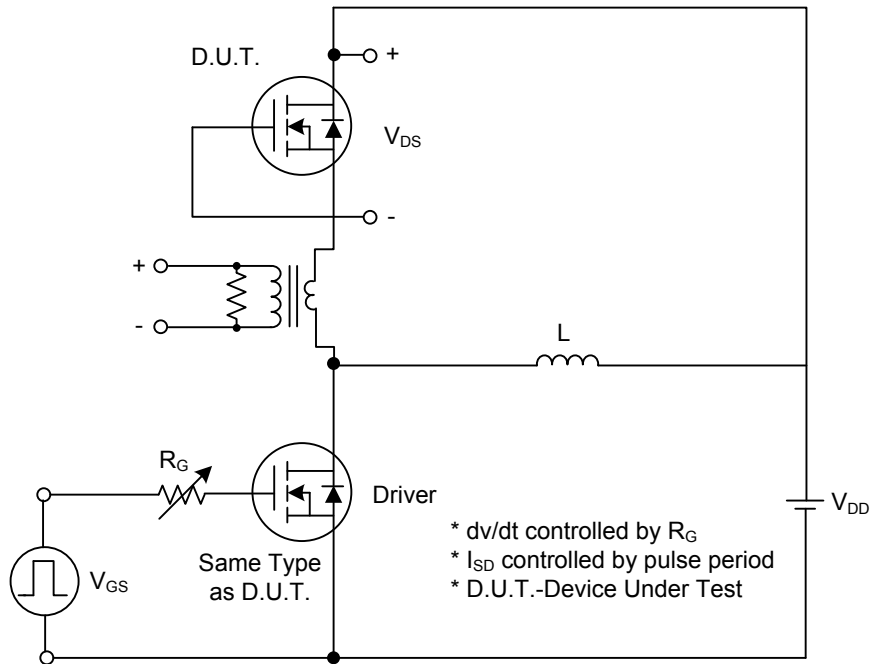

Peak Diode Recovery dv/dt Test Circuit

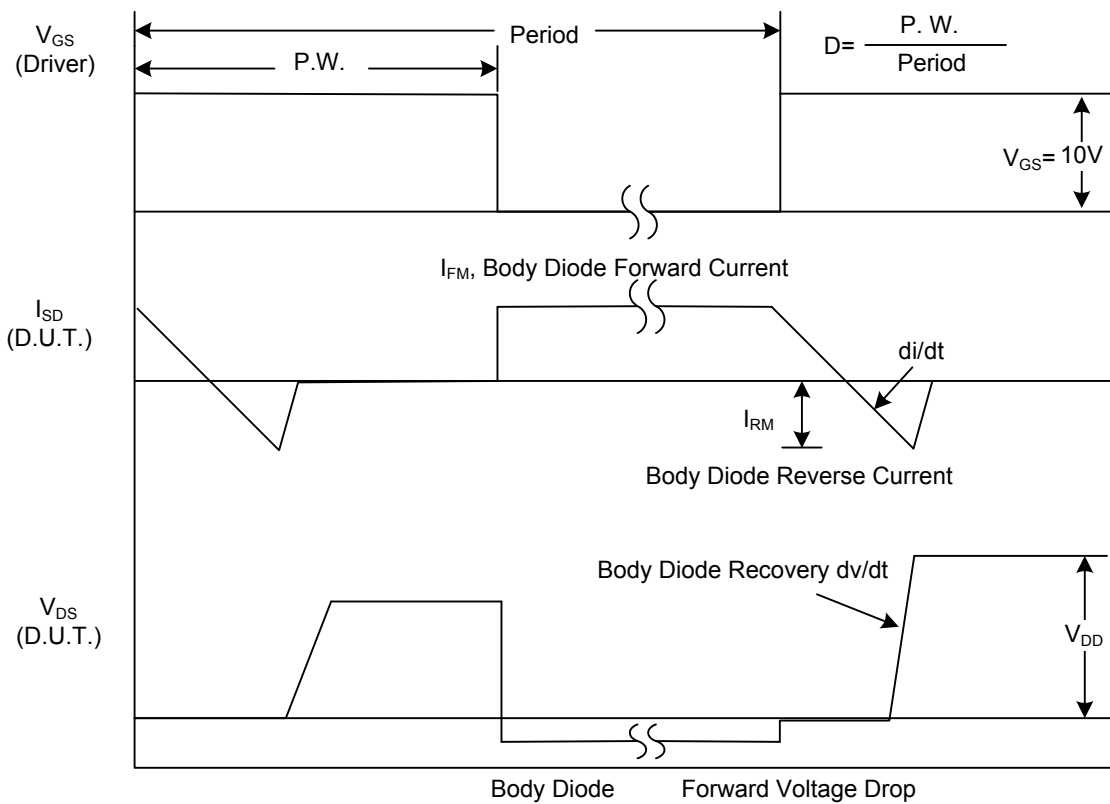

Peak Diode Recovery dv/dt Waveforms

■ TEST CIRCUITS AND WAVEFORMS (Cont.)

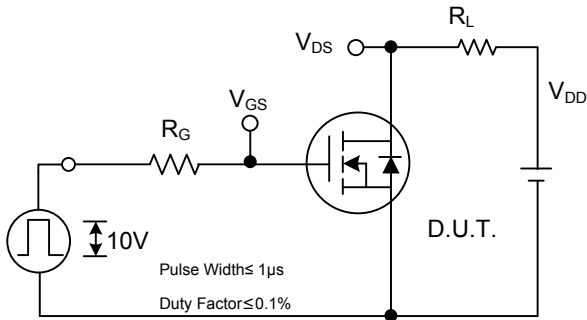

Switching Test Circuit

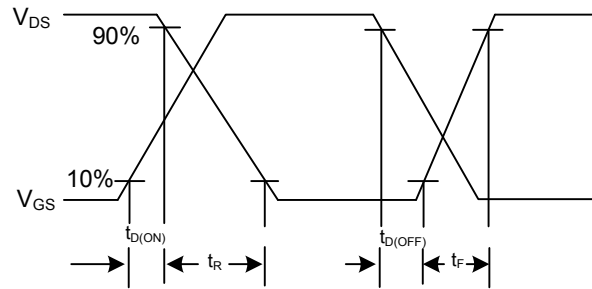

Switching Waveforms

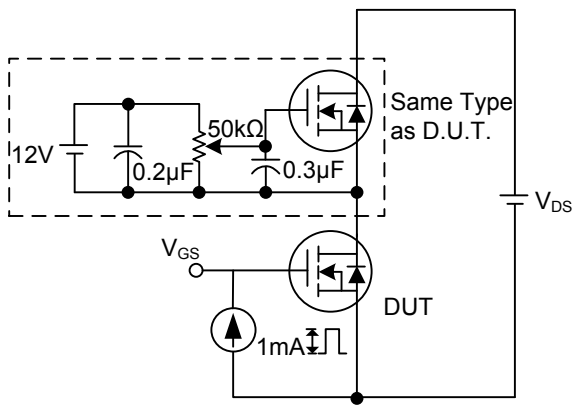

Gate Charge Test Circuit

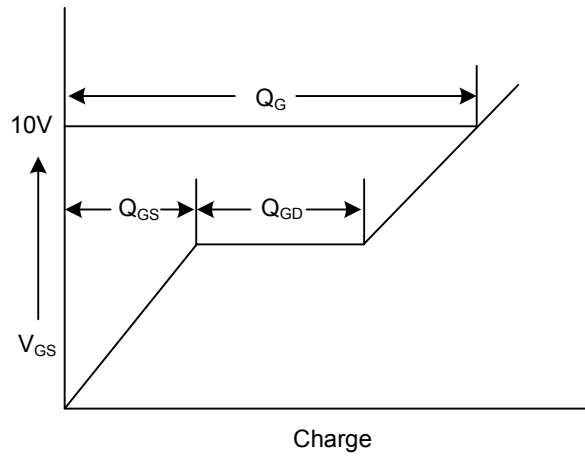

Gate Charge Waveform

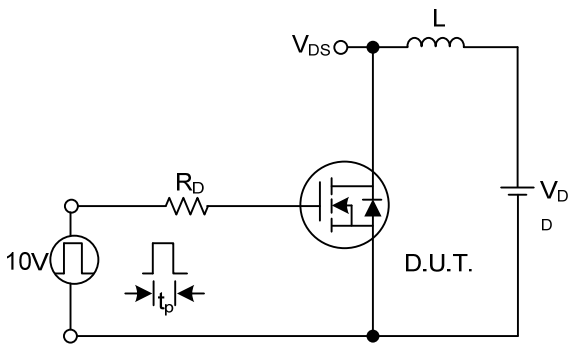

Unclamped Inductive Switching Test Circuit

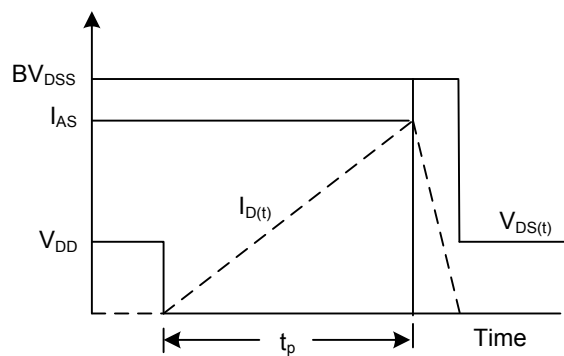

Unclamped Inductive Switching Waveforms

■ TYPICAL CHARACTERISTICS

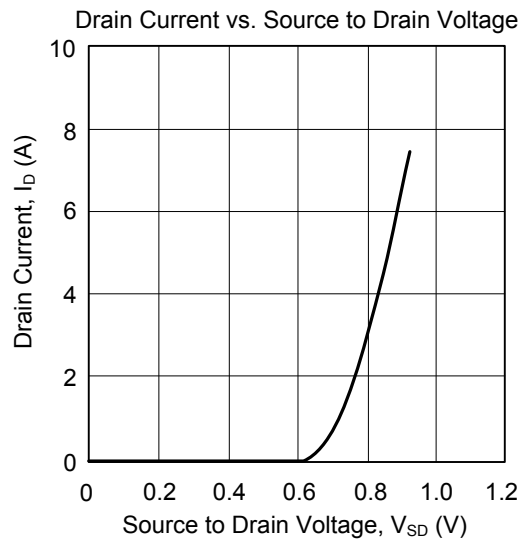
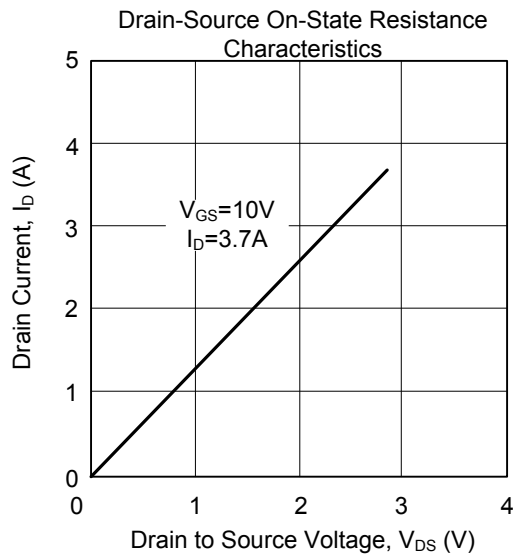
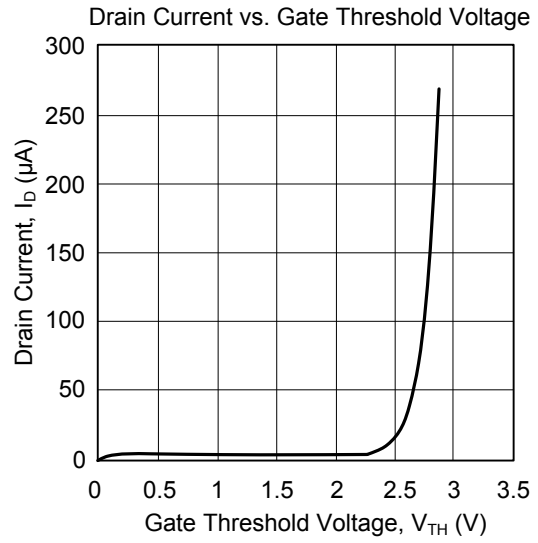
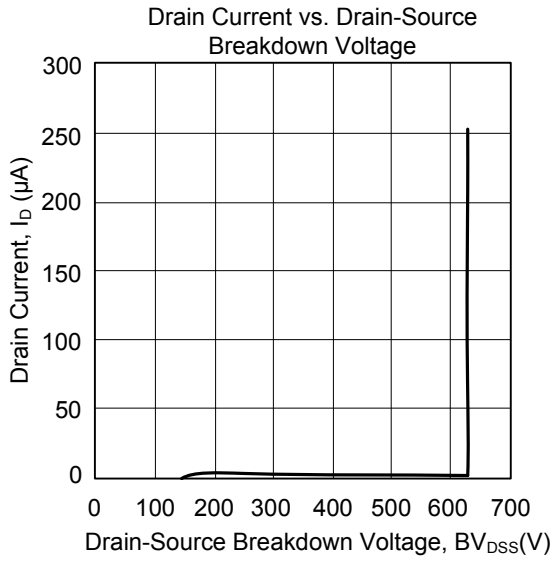

UTC assumes no responsibility for equipment failures that result from using products at values that exceed, even momentarily, rated values (such as maximum ratings, operating condition ranges, or other parameters) listed in products specifications of any and all UTC products described or contained herein. UTC products are not designed for use in life support appliances, devices or systems where malfunction of these products can be reasonably expected to result in personal injury. Reproduction in whole or in part is prohibited without the prior written consent of the copyright owner. The information presented in this document does not form part of any quotation or contract, is believed to be accurate and reliable and may be changed without notice.