



15N60

Power MOSFET

15A, 600V N-CHANNEL POWER MOSFET

DESCRIPTION

The UTC **15N60** is an N-channel mode power MOSFET using UTC's advanced technology to provide costumers with planar stripe and DMOS technology. This technology is specialized in allowing a minimum on-state resistance and superior switching performance. It also can withstand high energy pulse in the avalanche and commutation mode.

The UTC **15N60** is universally applied in active power factor correction and high efficient switched mode power supplies.

FEATURES

- * $R_{DS(ON)} \leq 0.65 \Omega @ V_{GS}=10V, I_D=7.5A$
- * High switching speed
- * Improved dv/dt capability

SYMBOL

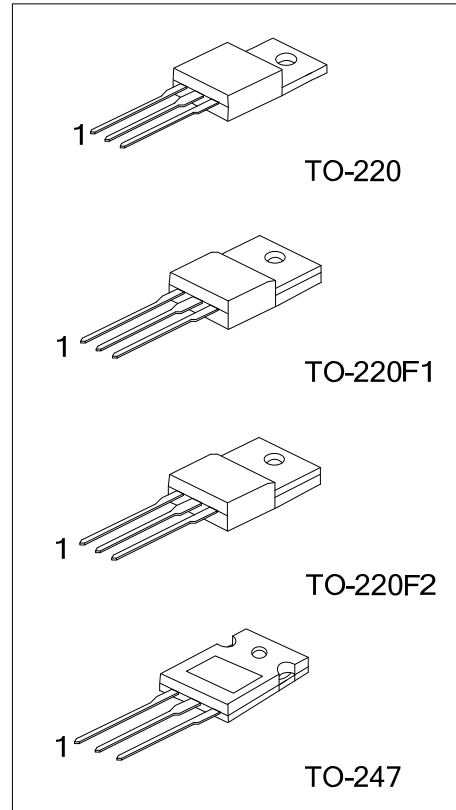
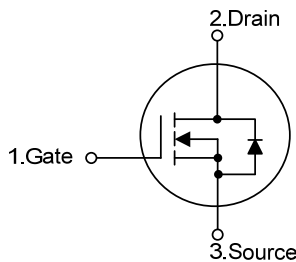

ORDERING INFORMATION

Ordering Number		Package	Pin Assignment			Packing
Lead Free	Halogen Free		1	2	3	
15N60L-TA3-T	15N60G-TA3-T	TO-220	G	D	S	Tube
15N60L-TF1-T	15N60G-TF1-T	TO-220F1	G	D	S	Tube
15N60L-TF2-T	15N60G-TF2-T	TO-220F2	G	D	S	Tube
15N60L-T47-T	15N60G-T47-T	TO-247	G	D	S	Tube

Note: Pin Assignment: G: Gate D: Drain S: Source

<p>15N60G-TA3-T</p>	<p>(1) T: Tube (2) TA3: TO-220, TF1: TO-220F1, TF2: TO-220F2, T47: TO-247 (3) G: Halogen Free and Lead Free, L: Lead Free</p>
---------------------	---

■ MARKING

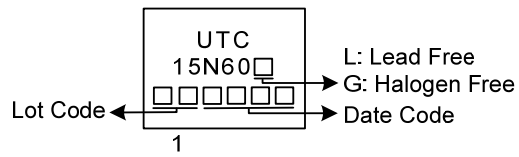

■ ABSOLUTE MAXIMUM RATINGS ($T_c=25^\circ\text{C}$, unless otherwise specified)

PARAMETER		SYMBOL	RATINGS	UNIT
Drain to Source Voltage		V_{DSS}	600	V
Gate to Source Voltage		V_{GSS}	± 30	V
Continuous Drain Current	Continuous	I_D	15	A
	Pulsed (Note 2)	I_{DM}	60	A
Avalanche Current (Note 2)		I_{AR}	6.4	A
Avalanche Energy	Single Pulsed (Note 3)	E_{AS}	205	mJ
Peak Diode Recovery dv/dt (Note 4)		dv/dt	2.45	V/ns
Power Dissipation	TO-220	P_D	250	W
	TO-220F1		54	W
	TO-220F2		52	W
	TO-247		312	W
Junction Temperature		T_J	+150	$^\circ\text{C}$
Storage Temperature		T_{STG}	-55 ~ +150	$^\circ\text{C}$

Notes: 1. Absolute maximum ratings are those values beyond which the device could be permanently damaged.

Absolute maximum ratings are stress ratings only and functional device operation is not implied.

2. Repetitive Rating: Pulse width limited by maximum junction temperature.

3. $L=10\text{mH}$, $I_{AS}=6.4\text{A}$, $V_{DD}=50\text{V}$, $R_G=25\Omega$, Starting $T_J=25^\circ\text{C}$

4. $I_{SD}\leq 15\text{A}$, $di/dt\leq 200\text{A}/\mu\text{s}$, $V_{DD}\leq BV_{DSS}$, Starting $T_J=25^\circ\text{C}$

■ THERMAL DATA

PARAMETER		SYMBOL	RATINGS	UNIT
Junction to Ambient	TO-220/TO-220F1	θ_{JA}	62.5	$^\circ\text{C}/\text{W}$
	TO-220F2			
	TO-247			
Junction to Case	TO-220	θ_{JC}	0.5	$^\circ\text{C}/\text{W}$
	TO-220F1		2.3	$^\circ\text{C}/\text{W}$
	TO-220F2		2.4	$^\circ\text{C}/\text{W}$
	TO-247		0.4	$^\circ\text{C}/\text{W}$

■ ELECTRICAL CHARACTERISTICS (T_c=25°C, unless otherwise specified)

PARAMETER	SYMBOL	TEST CONDITIONS	MIN	TYP	MAX	UNIT
OFF CHARACTERISTICS						
Drain-Source Breakdown Voltage	BV _{DSS}	V _{GS} =0V, I _D =250μA	600			V
Drain-Source Leakage Current	I _{DSS}	V _{DS} =600V, V _{GS} =0V			1	μA
Gate- Source Leakage Current	Forward	I _{GSS}			+100	nA
	Reverse				-100	nA
ON CHARACTERISTICS						
Gate Threshold Voltage	V _{GS(TH)}	V _{DS} =V _{GS} , I _D =250μA	2.0		4.0	V
Drain-Source On-State Resistance	R _{DS(ON)}	V _{GS} =10V, I _D =7.5A			0.65	Ω
DYNAMIC PARAMETERS						
Input Capacitance	C _{ISS}	V _{DS} =25V, V _{GS} =0V, f=1.0MHz		2600		pF
Output Capacitance	C _{OSS}			260		pF
Reverse Transfer Capacitance	C _{RSS}			22		pF
SWITCHING PARAMETERS						
Total Gate Charge (Note 1)	Q _G	V _{DS} =50V, V _{GS} =10V, I _D =1.3A, I _G = 100μA (Note 1, 2)		155		nC
Gate-Source Charge	Q _{GS}			14		nC
Gate-Drain Charge	Q _{GD}			28		nC
Turn-ON Delay Time (Note 1)	t _{D(ON)}	V _{DD} =30V, V _{GS} =10V, I _D =0.5A, R _G =25Ω (Note 1, 2)		105		ns
Turn-ON Rise Time	t _R			115		ns
Turn-OFF Delay Time	t _{D(OFF)}			600		ns
Turn-OFF Fall Time	t _F			120		ns
SOURCE- DRAIN DIODE RATINGS AND CHARACTERISTICS						
Maximum Body-Diode Continuous Current	I _S				15	A
Maximum Body-Diode Pulsed Current (Note 1)	I _{SM}				60	A
Drain-Source Diode Forward Voltage (Note 1)	V _{SD}	I _S =15A, V _{GS} =0V			1.4	V
Body Diode Reverse Recovery Time	t _{rr}	I _S =15A, V _{GS} =0V, dI _F /dt=100A/μs (Note 1)		510		ns
Body Diode Reverse Recovery Charge	Q _{rr}				8.2	

Notes: 1. Pulse Test : Pulse width ≤ 300μs, Duty cycle ≤ 2%.

2. Essentially independent of operating temperature.

■ TEST CIRCUITS AND WAVEFORMS

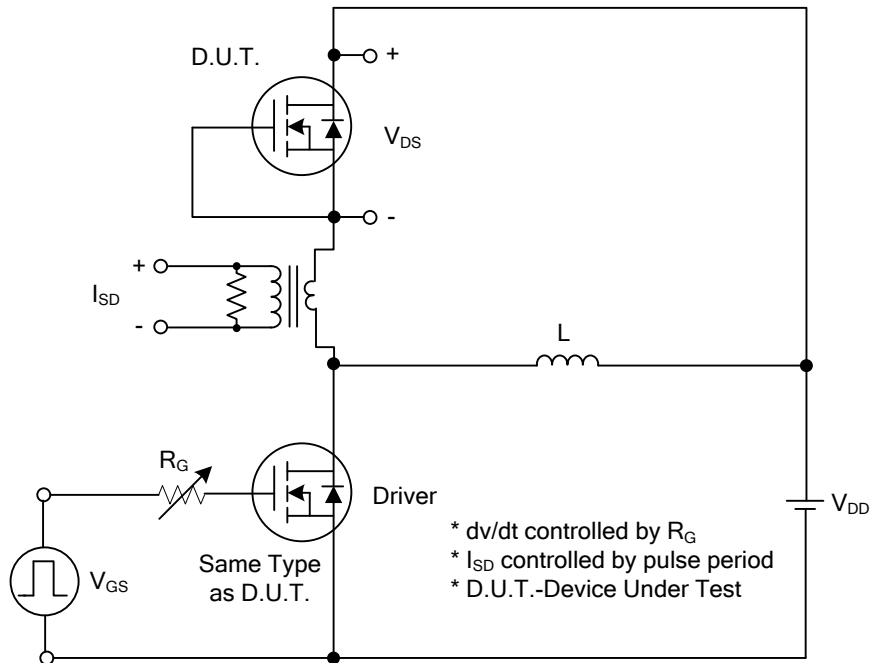

Peak Diode Recovery dv/dt Test Circuit

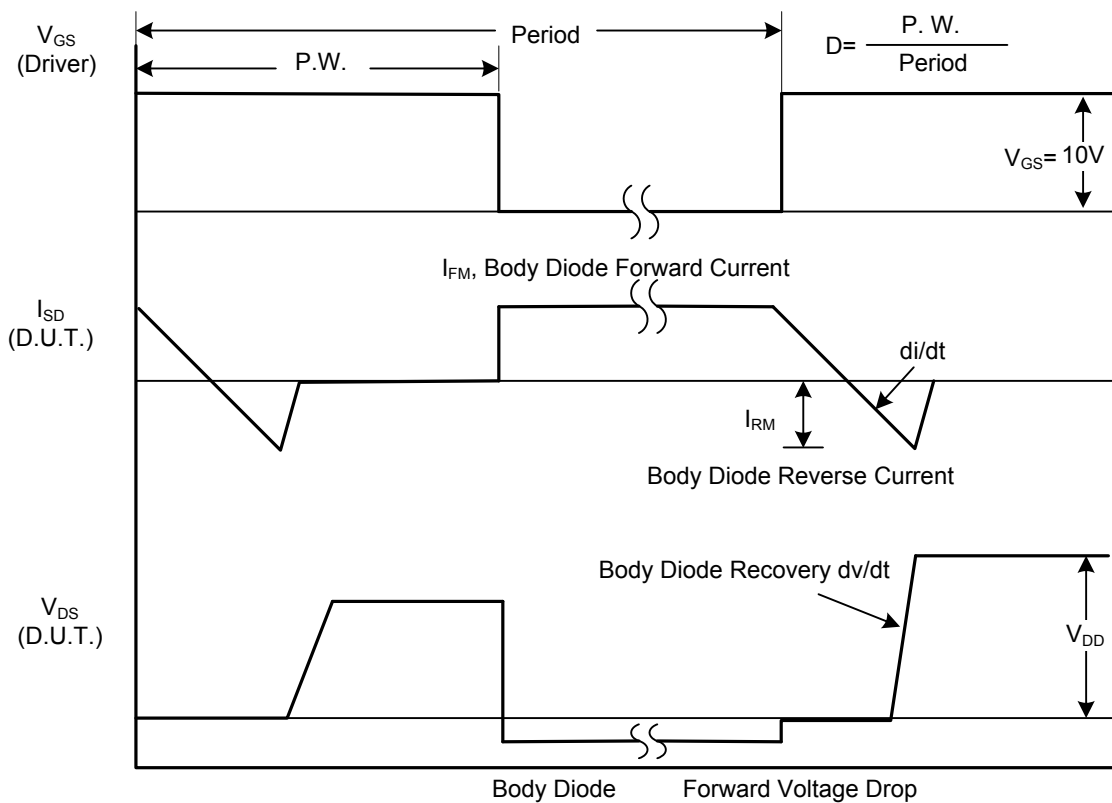

Peak Diode Recovery dv/dt Waveforms

TEST CIRCUITS AND WAVEFORMS

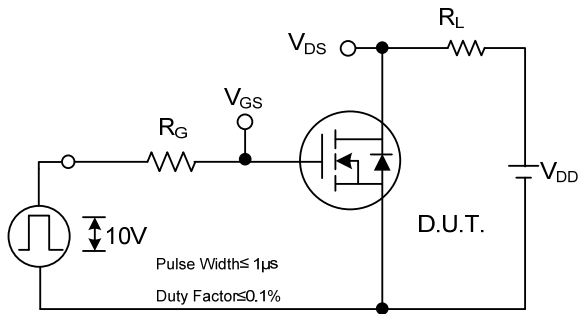

Switching Test Circuit

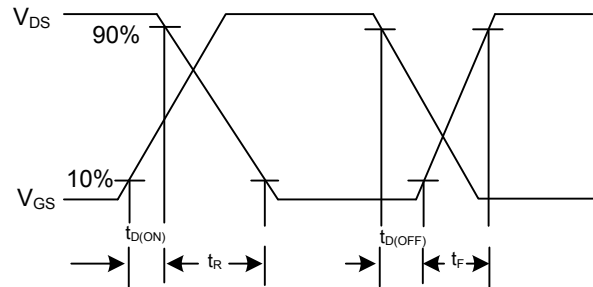

Switching Waveforms

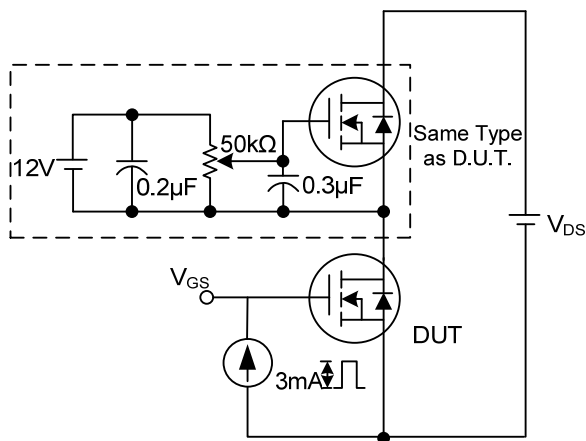

Gate Charge Test Circuit

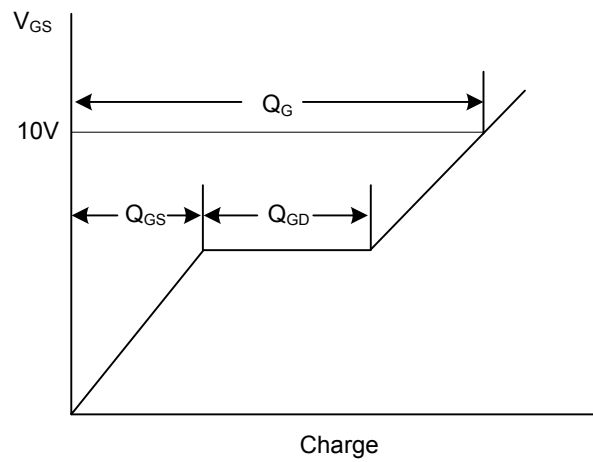

Gate Charge Waveform

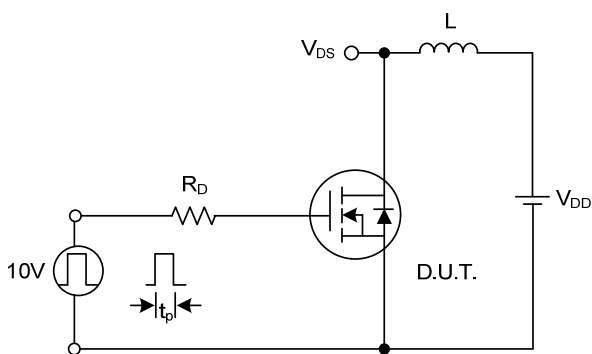

Unclamped Inductive Switching Test Circuit

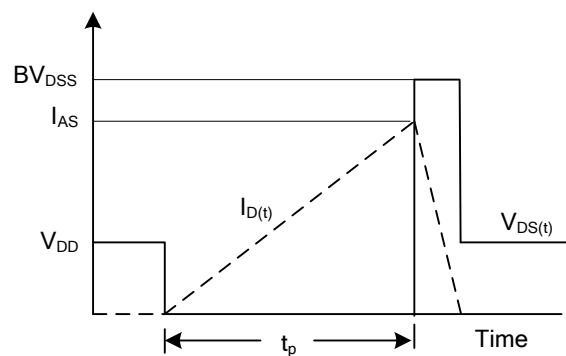

Unclamped Inductive Switching Waveforms

■ TYPICAL CHARACTERISTICS

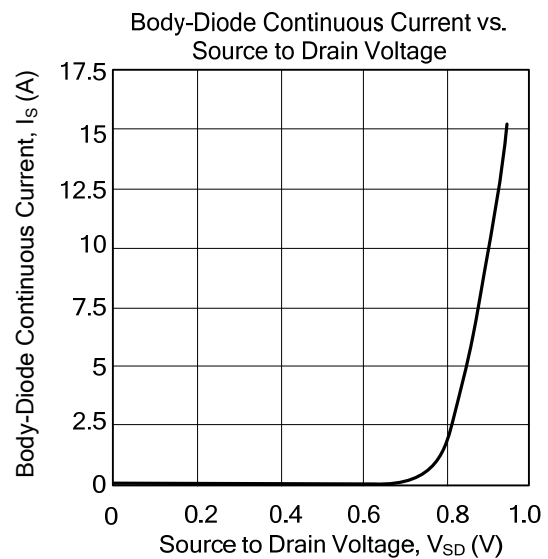
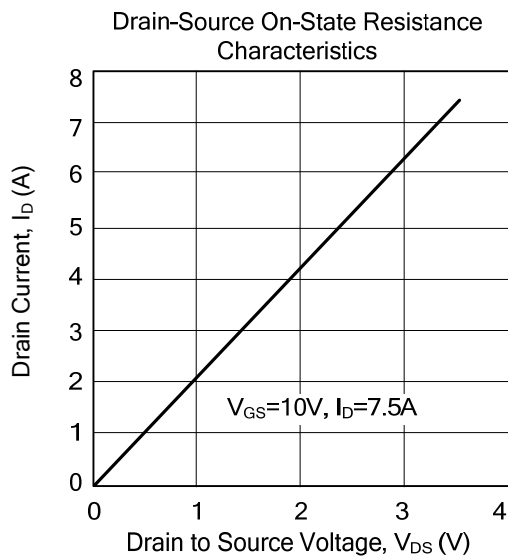
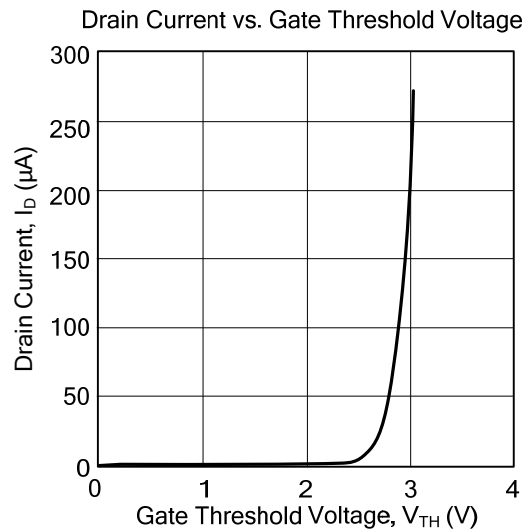
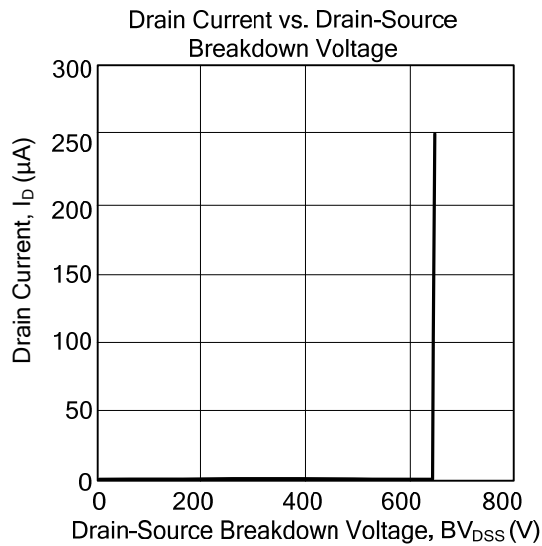

UTC assumes no responsibility for equipment failures that result from using products at values that exceed, even momentarily, rated values (such as maximum ratings, operating condition ranges, or other parameters) listed in products specifications of any and all UTC products described or contained herein. UTC products are not designed for use in life support appliances, devices or systems where malfunction of these products can be reasonably expected to result in personal injury. Reproduction in whole or in part is prohibited without the prior written consent of the copyright owner. UTC reserves the right to make changes to information published in this document, including without limitation specifications and product descriptions, at any time and without notice. This document supersedes and replaces all information supplied prior to the publication hereof.