



## 9014

## NPN SILICON TRANSISTOR

### PRE-AMPLIFIER, LOW LEVEL & LOW NOISE

#### FEATURES

- \* High total power dissipation. (450mW)
- \* Excellent  $h_{FE}$  linearity.
- \* Complementary to UTC **9015**

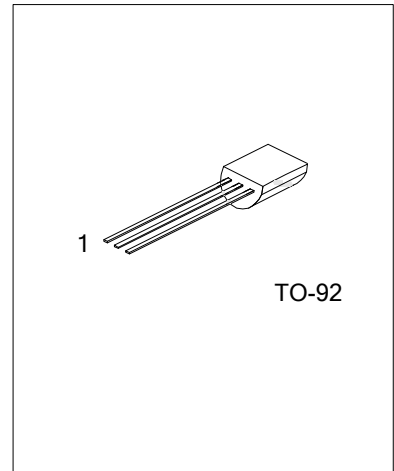

#### ORDERING INFORMATION

Ordering Number		Package	Pin Assignment			Packing
Lead Free	Halogen Free		1	2	3	
9014L-x-T92-B	9014G-x-T92-B	TO-92	E	B	C	Tape Box
9014L-x-T92-K	9014G-x-T92-K	TO-92	E	B	C	Bulk

Note: Pin assignment: E: Emitter B: Base C: Collector

<p>9014L-x-T92-B</p>	<p>(1) B: Tape Box, K: Bulk</p> <p>(2) T92: TO-92</p> <p>(3) x: refer to Classification of <math>h_{FE}</math></p> <p>(4) L: Lead Free, G: Halogen Free</p>
----------------------	---

#### MARKING INFORMATION

PACKAGE	MARKING
TO-92	<p>Rank ← → Data Code</p> <p>1</p> <p>UTC 9014 □ □ □ □ □</p> <p>L: Lead Free G: Halogen Free</p>

■ ABSOLUTE MAXIMUM RATINGS ( $T_A=25^\circ\text{C}$ , unless otherwise specified)

PARAMETER	SYMBOL	RATINGS	UNIT
Collector-Base Voltage	$V_{CBO}$	50	V
Collector-Emitter Voltage	$V_{CEO}$	45	V
Emitter-Base Voltage	$V_{EBO}$	5	V
Collector Current	$I_C$	100	mA
Collector Dissipation	$P_C$	450	mW
Junction Temperature	$T_J$	+150	$^\circ\text{C}$
Storage Temperature	$T_{STG}$	-55 ~ +150	$^\circ\text{C}$

Note: Absolute maximum ratings are those values beyond which the device could be permanently damaged. Absolute maximum ratings are stress ratings only and functional device operation is not implied.

■ ELECTRICAL CHARACTERISTICS ( $T_A=25^\circ\text{C}$ , unless otherwise specified)

PARAMETER	SYMBOL	TEST CONDITIONS	MIN	TYP	MAX	UNIT
Collector-Base Breakdown Voltage	$BV_{CBO}$	$I_C=100\mu\text{A}$ , $I_E=0$	50			V
Collector-Emitter Breakdown Voltage	$BV_{CEO}$	$I_C=1\text{mA}$ , $I_B=0$	45			V
Emitter-Base Breakdown Voltage	$BV_{EBO}$	$I_E=100\mu\text{A}$ , $I_C=0$	5			V
Collector Cut-Off Current	$I_{CBO}$	$V_{CB}=50\text{V}$ , $I_E=0$			50	nA
Emitter Cut-Off Current	$I_{EBO}$	$V_{EB}=5\text{V}$ , $I_C=0$			100	nA
DC Current Gain	$h_{FE}$	$V_{CE}=5\text{V}$ , $I_C=1\text{mA}$	60	280	1000	
Collector-Emitter saturation voltage	$V_{CE(SAT)}$	$I_C=100\text{mA}$ , $I_B=5\text{mA}$		0.14	0.3	V
Base-Emitter saturation voltage	$V_{BE(SAT)}$	$I_C=100\text{mA}$ , $I_B=5\text{mA}$		0.84	1.0	V
Base-Emitter on voltage	$V_{BE(ON)}$	$V_{CE}=5\text{V}$ , $I_C=2\text{mA}$	0.58	0.63	0.7	V
Output Capacitance	$C_{ob}$	$V_{CB}=10\text{V}$ , $I_E=0$ , $f=1\text{MHz}$		2.2	3.5	pF
Current Gain-Bandwidth Product	$f_T$	$V_{CE}=5\text{V}$ , $I_C=10\text{mA}$	150	270		MHz
Noise Figure	NF	$V_{CE}=5\text{V}$ , $I_C=0.2\text{mA}$ $f=1\text{KHz}$ , $R_S=2\text{K}\Omega$		0.9	10	dB

■ CLASSIFICATION OF  $h_{FE}$

RANK	A	B	C	D
RANGE	60-150	100-300	200-600	400-1000

■ TYPICAL CHARACTERISTICS

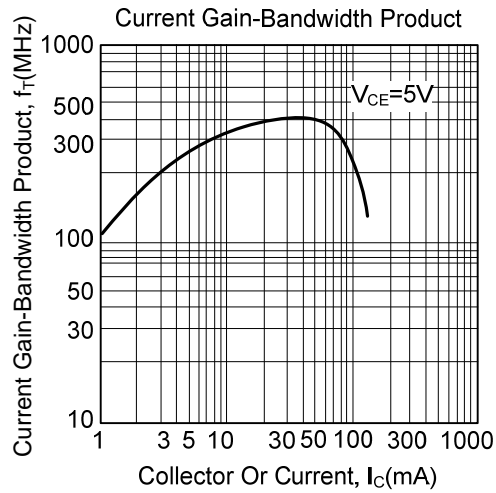
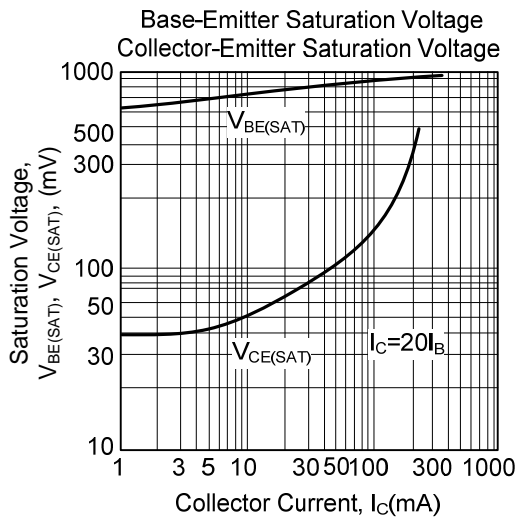
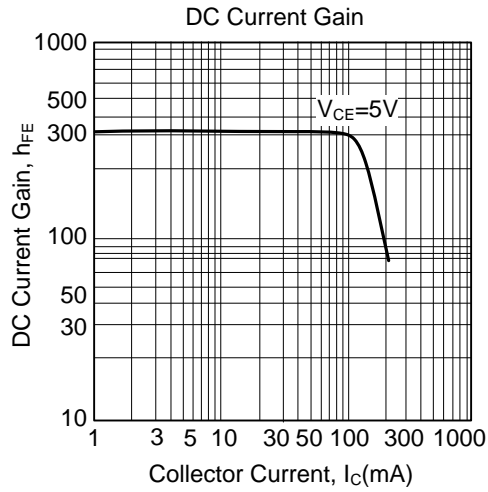
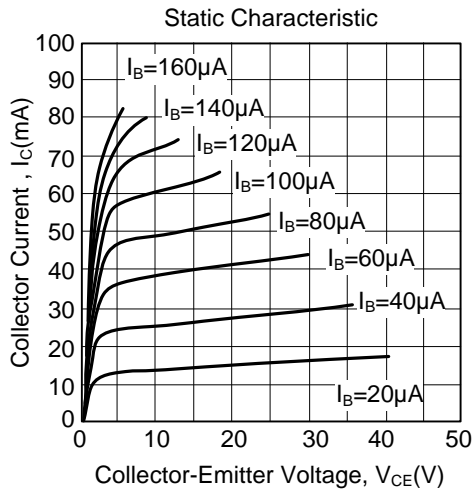

UTC assumes no responsibility for equipment failures that result from using products at values that exceed, even momentarily, rated values (such as maximum ratings, operating condition ranges, or other parameters) listed in products specifications of any and all UTC products described or contained herein. UTC products are not designed for use in life support appliances, devices or systems where malfunction of these products can be reasonably expected to result in personal injury. Reproduction in whole or in part is prohibited without the prior written consent of the copyright owner. The information presented in this document does not form part of any quotation or contract, is believed to be accurate and reliable and may be changed without notice.