



# 2SA1797

## PNP SILICON TRANSISTOR

### POWER TRANSISTOR

■ FEATURES

- \* Low Saturation Voltage.  
 $V_{CE(SAT)} = -0.35V(MAX)$  at  $I_C / I_B = -1A / -50mA$
- \* Excellent DC Current Gain Characteristics

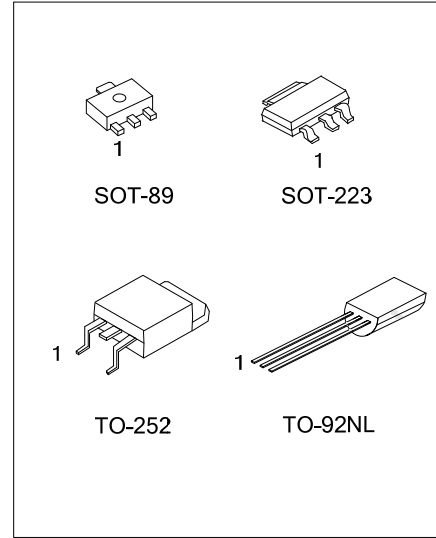

■ ORDERING INFORMATION

Ordering Number		Package	Pin Assignment			Packing
Lead Free	Halogen Free		1	2	3	
2SA1797L-x-AA3-R	2SA1797G-x-AA3-R	SOT-223	B	C	E	Tape Reel
2SA1797L-x-AB3-R	2SA1797G-x-AB3-R	SOT-89	B	C	E	Tape Reel
2SA1797L-x-T9N-B	2SA1797G-x-T9N-B	TO-92NL	E	C	B	Tape Box
2SA1797L-x-T9N-K	2SA1797G-x-T9N-K	TO-92NL	E	C	B	Bulk
2SA1797L-x-TN3-R	2SA1797G-x-TN3-R	TO-252	B	C	E	Tape Reel

Note: Pin Assignment: B: Base C: Collector E: Emitter

<p>2SA1797G-x-AA3-R</p> <p>(1)Packing Type          (2)Package Type          (3)Rank          (4)Green Package</p>	<p>(1) R: Tape Reel, B: Tape Box, K: Bulk          (2) AA3: SOT-223, AB3: SOT-89, T9N: TO-92NL, TN3: TO-252          (3) refer to Classification of hFE          (4) G: Halogen Free and Lead Free, L: Lead Free</p>
--	--

■ MARKING

<p>SOT-89</p>	<p>SOT-223</p>
<p>TO-252</p>	<p>TO-92NL</p>

■ ABSOLUTE MAXIMUM RATINGS ( $T_A=25^{\circ}\text{C}$ , unless otherwise specified)

PARAMETER		SYMBOL	RATINGS	UNIT
Collector-Base Voltage		$V_{CBO}$	-50	V
Collector-Emitter Voltage		$V_{CEO}$	-50	V
Emitter-Base Voltage		$V_{EBO}$	-6	V
Collector Current	DC	$I_C$	-2	A
	PULSE(Note 2)		-5	A
Collector Power Dissipation	TO-92NL	$P_C$	0.6	W
	SOT-223		0.8 (Note 3)	W
	SOT-89		0.9 (Note 3)	W
	TO-252		1.9 (Note 3)	W
Junction Temperature		$T_J$	+150	$^{\circ}\text{C}$
Storage Temperature		$T_{STG}$	-55 ~ +150	$^{\circ}\text{C}$

Notes: 1. Absolute maximum ratings are those values beyond which the device could be permanently damaged.

Absolute maximum ratings are stress ratings only and functional device operation is not implied.

2. Single pulse,  $P_W=10\text{ms}$ .

3. Device mounted on FR-4 PCB with minimum recommended pad layout.

■ ELECTRICAL CHARACTERISTICS ( $T_A=25^{\circ}\text{C}$ , unless otherwise specified)

PARAMETER	SYMBOL	TEST CONDITIONS	MIN	TYP	MAX	UNIT
Collector-Base Breakdown Voltage	$BV_{CBO}$	$I_C = -50\mu\text{A}$	-50			V
Collector-Emitter Breakdown Voltage	$BV_{CEO}$	$I_C = -1\text{mA}$	-50			V
Emitter-Base Breakdown Voltage	$BV_{EBO}$	$I_E = -50\mu\text{A}$	-6			V
Collector Cutoff Current	$I_{CBO}$	$V_{CB} = -50\text{V}$			-0.1	$\mu\text{A}$
Emitter Cutoff Current	$I_{EBO}$	$V_{EB} = -5\text{V}$			-0.1	$\mu\text{A}$
Collector-Emitter Saturation Voltage	$V_{CE(SAT)}$	$I_C/I_B = -1\text{A}/-50\text{mA}$ (Note)		-0.15	-0.35	V
DC Current Gain	$h_{FE}$	$V_{CE} = -2\text{V}$ , $I_C = -0.5\text{A}$ (Note)	120		400	
Transition Frequency	$f_T$	$V_{CE} = -2\text{V}$ , $I_E = 0.5\text{A}$ , $f = 100\text{MHz}$		200		MHz
Output Capacitance	$C_{OB}$	$V_{CB} = -10\text{V}$ , $I_E = 0\text{A}$ , $f = 1\text{MHz}$		36		pF

Note: Measured using pulse current.

■ CLASSIFICATION OF  $h_{FE}$

RANK	A	B
RANGE	120-240	200-400

## TYPICAL CHARACTERISTICS

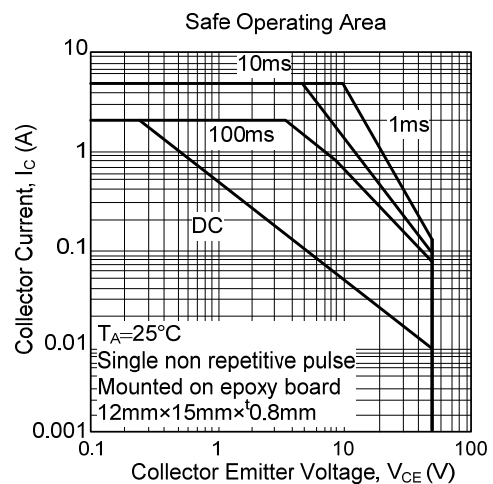
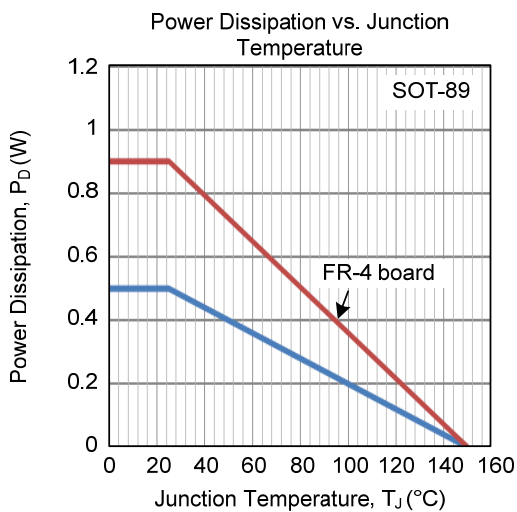
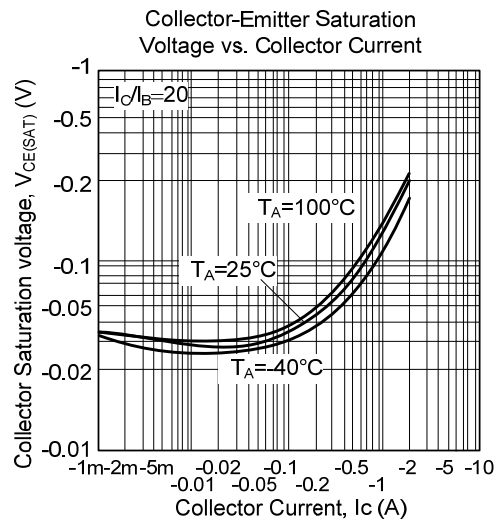
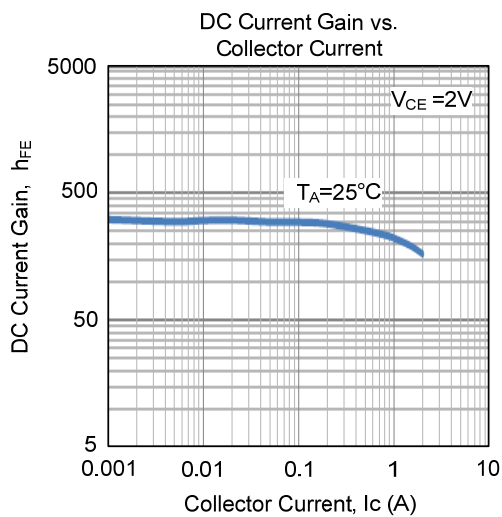
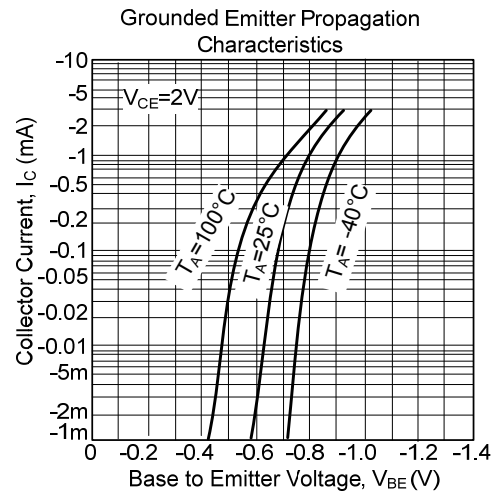
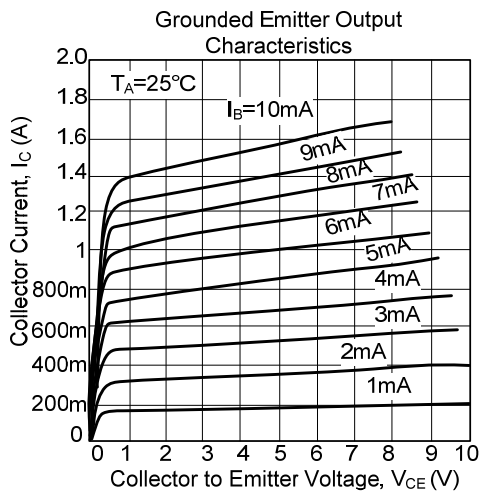

UTC assumes no responsibility for equipment failures that result from using products at values that exceed, even momentarily, rated values (such as maximum ratings, operating condition ranges, or other parameters) listed in products specifications of any and all UTC products described or contained herein. UTC products are not designed for use in life support appliances, devices or systems where malfunction of these products can be reasonably expected to result in personal injury. Reproduction in whole or in part is prohibited without the prior written consent of the copyright owner. UTC reserves the right to make changes to information published in this document, including without limitation specifications and product descriptions, at any time and without notice. This document supersedes and replaces all information supplied prior to the publication hereof.