



PN2907A

PNP SILICON TRANSISTOR

PNP GENERAL PURPOSE AMPLIFIER

■ DESCRIPTION

This UTC **PN2907A** is designed for use as a general purpose amplifier and switch requiring collector currents to 600 mA.

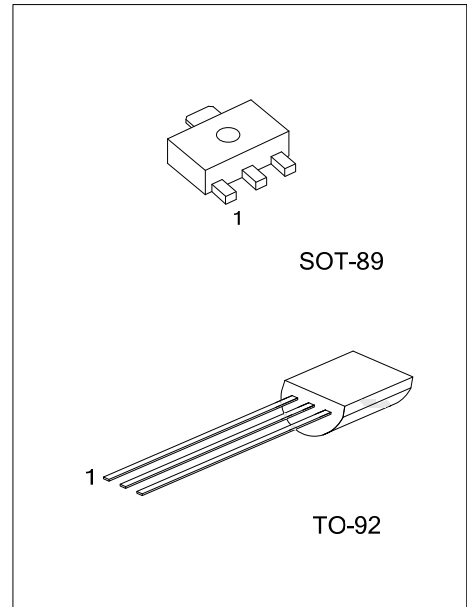

■ ORDERING INFORMATION

Ordering Number		Package	Pin Assignment			Packing
Lead Free	Halogen Free		1	2	3	
PN2907AL-AB3-R	PN2907AG-AB3-R	SOT-89	B	C	E	Tape Reel
PN2907AL-T92-B	PN2907AG-T92-B	TO-92	E	B	C	Tape Box
PN2907AL-T92-K	PN2907AG-T92-K	TO-92	E	B	C	Bulk

Note: Pin Assignment: E: Emitter C: Collector B: Base

<p>PN2907AG-AB3-R</p> <ul style="list-style-type: none"> (1) Packing Type (2) Package Type (3) Green Package 	<ul style="list-style-type: none"> (1) B: Tape Box, K: Bulk, R: Tape Reel (2) AB3: SOT-89, T92: TO-92 (3) G: Halogen Free and Lead Free, L: Lead Free
---	--

■ MARKING

SOT-89	TO-92
<p>→ Date Code → L: Lead Free → G: Halogen Free</p> <p>1</p>	<p>← L: Lead Free ← G: Halogen Free → Date Code</p> <p>1</p>

■ ABSOLUTE MAXIMUM RATINGS ($T_A=25^{\circ}\text{C}$, unless otherwise specified.)

PARAMETER		SYMBOL	RATINGS	UNIT
Collector-Emitter Voltage		V_{CEO}	-60	V
Collector-Base Voltage		V_{CBO}	-60	V
Emitter-Base Voltage		V_{EBO}	-5	V
Collector Current (Continuous)		I_C	-600	mA
Collector Current (Peak)		I_{CM}	-900	mA
Power Dissipation	SOT-89	P_D	1000 (Note 3)	mW
	TO-92		625	mW
Junction Temperature		T_J	+150	$^{\circ}\text{C}$
Storage Temperature		T_{STG}	-40 ~ +150	$^{\circ}\text{C}$

Notes: 1. Absolute maximum ratings are those values beyond which the device could be permanently damaged.

Absolute maximum ratings are stress ratings only and functional device operation is not implied.

2. These are steady state limits. The factory should be consulted on applications involving pulsed or low duty cycle operations.

3. Device mounted on FR-4 substrate PC board, 2oz copper, with 1inch square copper plate.

■ THERMAL DATA

PARAMETER		SYMBOL	RATINGS	UNIT
Thermal resistance, junction to Ambient	SOT-89	θ_{JA}	104	$^{\circ}\text{C}/\text{W}$
	TO-92		200	$^{\circ}\text{C}/\text{W}$

■ ELECTRICAL CHARACTERISTICS (T_A=25°C, unless otherwise specified.)

PARAMETER	SYMBOL	TEST CONDITIONS	MIN	TYP	MAX	UNIT
OFF CHARACTERISTICS						
Collector-Emitter Breakdown Voltage	BV _{CEO}	I _C =-10mA, I _B =0	-60			V
Collector-Base Breakdown Voltage	BV _{CBO}	I _C =-10μA, I _E =0	-60			V
Emitter-Base Breakdown Voltage	BV _{EBO}	I _E =-10μA, I _C =0	-5			V
Base Cutoff Current	I _B	V _{CB} =-30V, V _{EB} =-0.5V			-50	nA
Collector Cutoff Current	I _{CEX}	V _{CE} =-30V, V _{BE} =-0.5V			-50	nA
Collector Cutoff Current	I _{CBO}	V _{CB} =-50V, I _E =0 V _{CB} =-50V, I _E =0, T _a =150°C			-0.02 -20	μA μA
ON CHARACTERISTICS						
DC Current Gain	h _{FE}	I _C =-0.1mA, V _{CE} =-10V	75			
		I _C =-1.0 mA, V _{CE} =-10V	100			
		I _C =-10 mA, V _{CE} =-10V	100			
		I _C =-150 mA, V _{CE} =-10V (Note)	100		300	
		I _C =-500 mA, V _{CE} =-10V (Note)	50			
Collector-Emitter Saturation Voltage (Note)	V _{CE(SAT)}	I _C =-150mA, I _B =-15mA I _C =-500mA, I _B =-50mA			-0.4 -1.6	V V
Base-Emitter Saturation Voltage	V _{BE(SAT)}	I _C =-150mA, I _B =-15mA (Note) I _C =-500mA, I _B =-50mA			-1.3 -2.6	V V
SMALL SIGNAL CHARACTERISTICS						
Current Gain – Bandwidth Product	f _T	I _C =-50mA, V _{CE} =-20V, f=100MHz	200			MHz
Output Capacitance	C _{ob}	V _{CB} =-10V, I _E =0, f=100kHz			8	pF
Input Capacitance	C _{ib}	V _{EB} =-2V, I _C =0, f=100kHz			30	pF
SWITCHING CHARACTERISTICS						
Turn-on Time	t _{ON}	V _{CC} =-30V, I _C =-150mA I _{B1} =-15mA			45	ns
Delay Time	t _{DLY}				10	ns
Rise Time	t _R				40	ns
Turn-off Time	t _{OFF}	V _{CC} =-6V, I _C =-150mA I _{B1} =I _{B2} =-15mA			100	ns
Storage Time	t _S				80	ns
Fall Time	t _F				30	ns

Note: Pulse Test: Pulse Width ≤ 300ms, Duty Cycle ≤ 2.0%

■ TEST CIRCUITS

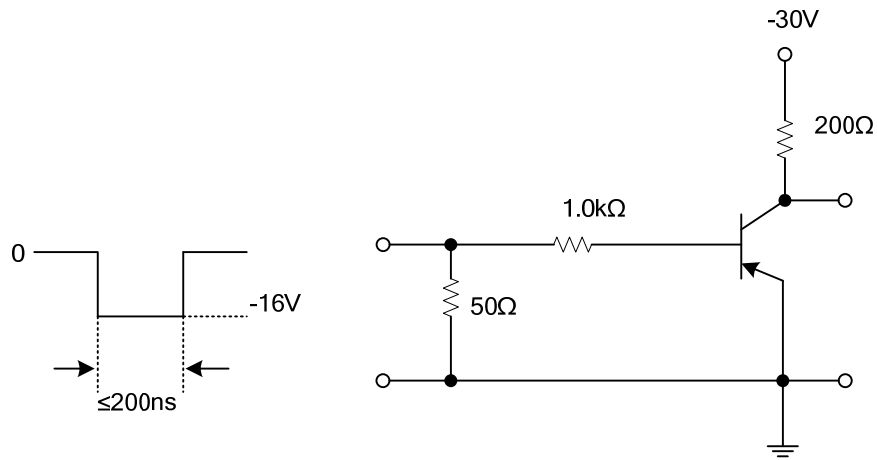

Fig. 1 Saturated Turn-On Switching Time Test Circuit

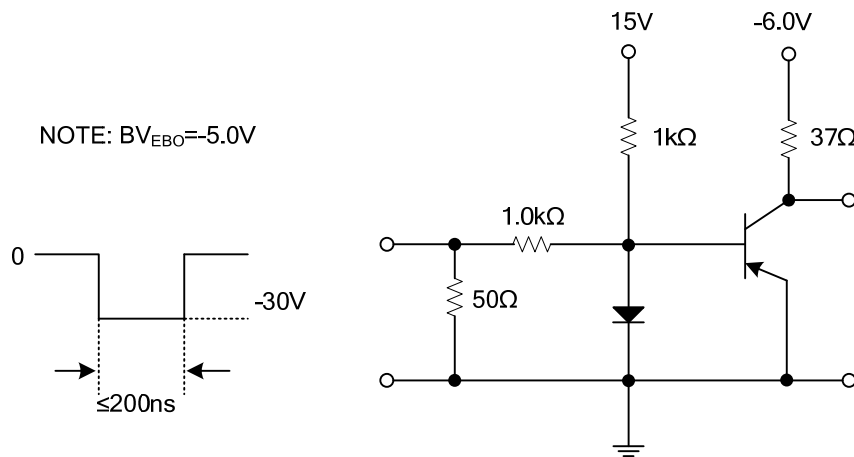
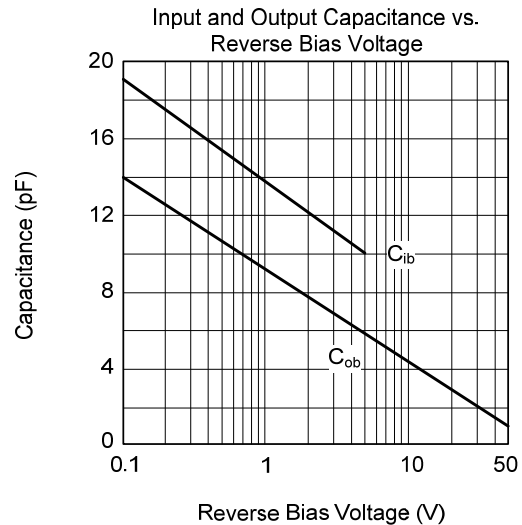
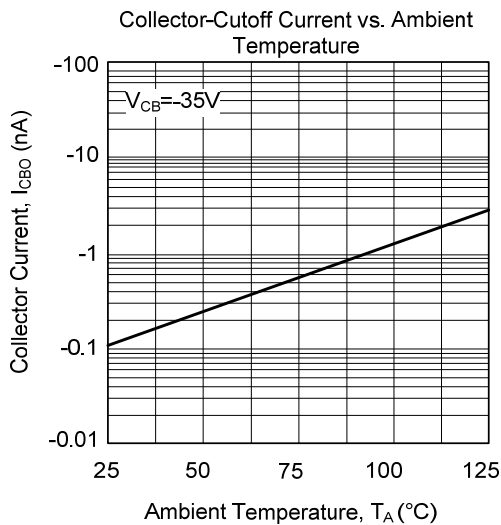
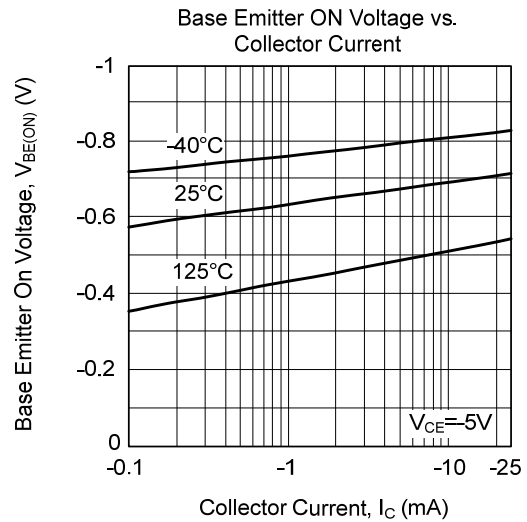
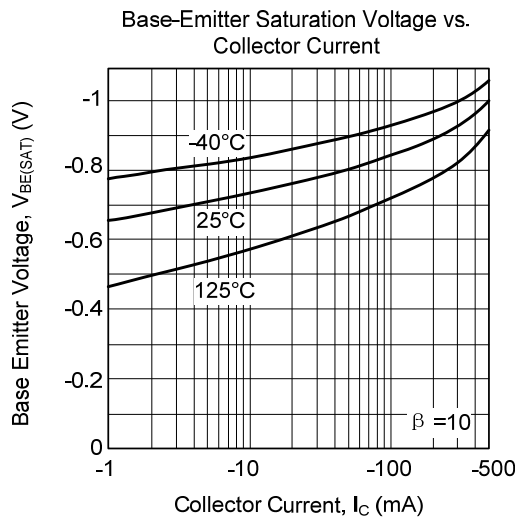
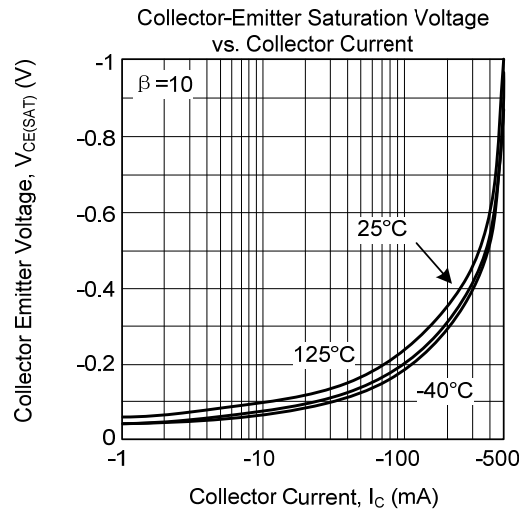
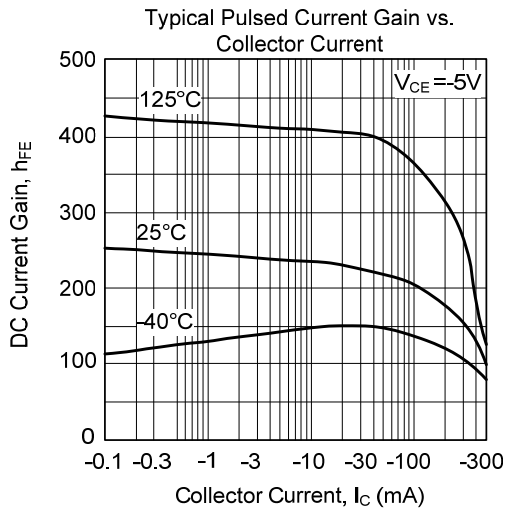
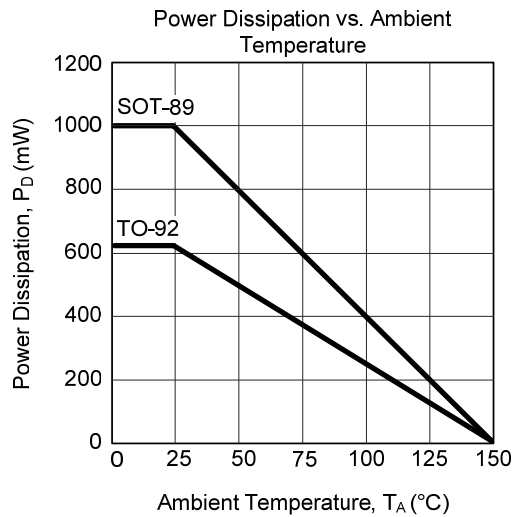
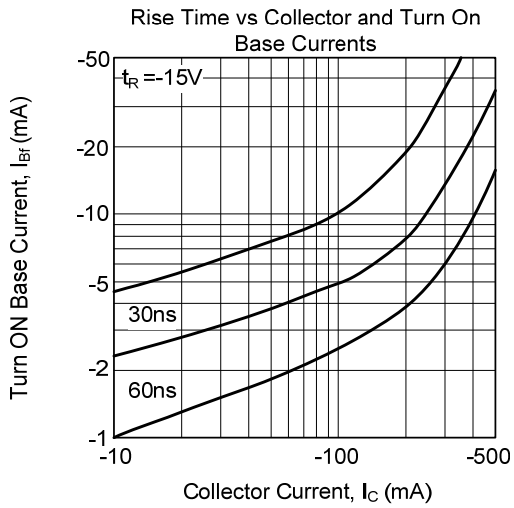
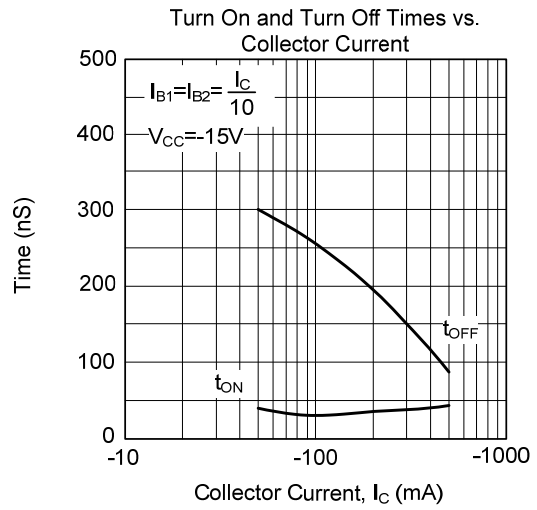
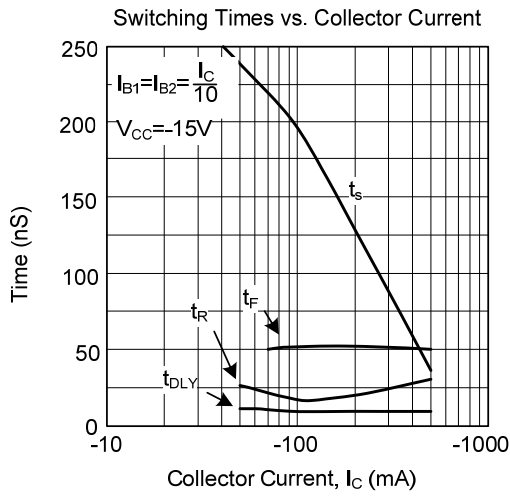

Fig. 2 Saturated Turn-Off Switching Time Test Circuit

TYPICAL CHARACTERISTICS



■ TYPICAL CHARACTERISTICS (Cont.)



■ TYPICAL CHARACTERISTICS (Cont.)

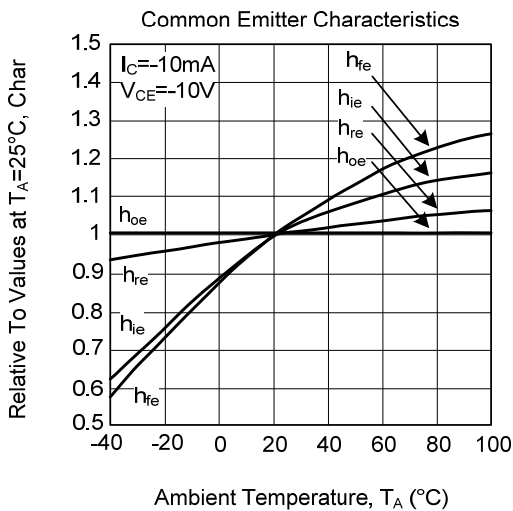
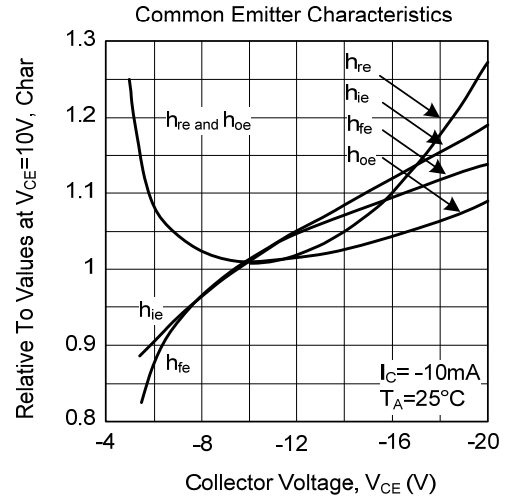
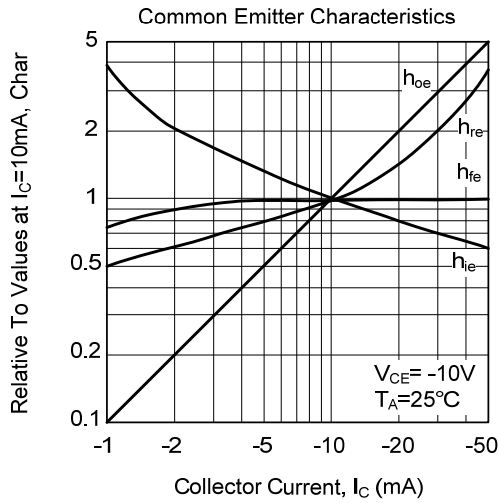

UTC assumes no responsibility for equipment failures that result from using products at values that exceed, even momentarily, rated values (such as maximum ratings, operating condition ranges, or other parameters) listed in products specifications of any and all UTC products described or contained herein. UTC products are not designed for use in life support appliances, devices or systems where malfunction of these products can be reasonably expected to result in personal injury. Reproduction in whole or in part is prohibited without the prior written consent of the copyright owner. UTC reserves the right to make changes to information published in this document, including without limitation specifications and product descriptions, at any time and without notice. This document supersedes and replaces all information supplied prior to the publication hereof.