



## TIP112

## NPN SILICON TRANSISTOR

### NPN EPITAXIAL SILICON DARLINGTON TRANSISTOR

#### DESCRIPTION

The UTC TIP112 is designed for such applications as: DC/DC converters supply line switching, battery charger, LCD backlighting, peripheral drivers, Driver in low supply voltage applications (e.g. lamps and LEDs) and inductive load driver (e.g. relays, buzzers and motors).

#### FEATURES

- \* High DC current gain :  $h_{FE} = 1000 @ V_{CE}=4V, I_C=1A$  (Min.)
- \* Low collector-emitter saturation voltage

#### EQUIVALENT TEST (R<sub>1</sub>≈10kΩ, R<sub>2</sub>≈0.6kΩ)

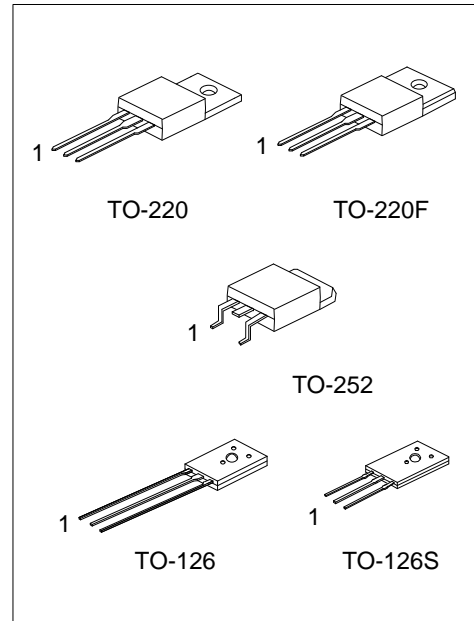
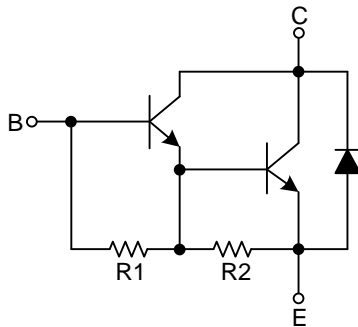

#### ORDERING INFORMATION

Ordering Number		Package	Pin Assignment			Packing
Lead Free	Halogen Free		1	2	3	
TIP112L-TA3-T	TIP112G-TA3-T	TO-220	B	C	E	Tube
TIP112L-TF3-T	TIP112G-TF3-T	TO-220F	B	C	E	Tube
TIP112L-TN3-R	TIP112G-TN3-R	TO-252	B	C	E	Tape Reel
TIP112L-T60-K	TIP112G-T60-K	TO-126	E	C	B	Bulk
TIP112L-T6S-K	TIP112G-T6S-K	TO-126S	E	C	B	Bulk

Note: Pin assignment: E: Emitter B: Base C: Collector

<p>TIP112G-TA3-T</p>	<p>(1) T: Tube, R: Tape Reel, K: Bulk  (2) TA3: TO-220, TF3: TO-220F, TN3: TO-252  T60: TO-126, T6S: TO-126S  (3) G: Halogen Free and Lead Free, L: Lead Free</p>
----------------------	---

## MARKING

TO-220 / TO-220F / TO-252	TO-126 / TO-126S
<p>UTC TIP122 □ □□□□ □ □□□□□□</p> <p>Lot Code ←</p> <p>→ L: Lead Free → G: Halogen Free → Date Code</p> <p>1</p>	<p>UTC □□□□ TIP122 □ □</p> <p>→ Date Code → L: Lead Free → G: Halogen Free</p> <p>1</p>

■ **ABSOLUTE MAXIMUM RATING** ( $T_C = 25^\circ\text{C}$ , unless otherwise specified)

PARAMETER		SYMBOL	RATINGS	UNIT
Collector to Base Voltage		$V_{CBO}$	100	V
Collector to Emitter Voltage		$V_{CEO}$	100	V
Emitter to Base Voltage		$V_{EBO}$	5	V
Collector Current	DC	$I_C$	2	A
	Peak	$I_{CM}$	4	
Base Current (DC)		$I_B$	50	mA
Collector Dissipation	TO-220	$P_C$	40	W
	TO-220F		15	
	TO-252		25	
	TO-126/TO-126S		10	
Junction Temperature		$T_J$	150	$^\circ\text{C}$
Storage Temperature		$T_{STG}$	-65~+150	$^\circ\text{C}$

Note: Absolute maximum ratings are those values beyond which the device could be permanently damaged. Absolute maximum ratings are stress ratings only and functional device operation is not implied.

■ **ELECTRICAL CHARACTERISTICS** ( $T_C = 25^\circ\text{C}$ , unless otherwise specified)

PARAMETER	SYMBOL	TEST CONDITIONS	MIN	TYP	MAX	UNIT
Collector-Emitter Breakdown Voltage	$V_{CEO(SUS)}$	$I_C=30\text{mA}$ , $I_B=0\text{A}$	100			V
Collector-Emitter Saturation Voltage	$V_{CE(SAT)}$	$I_C=2\text{A}$ , $I_B=8\text{mA}$			2.5	V
Base-Emitter Turn-On Voltage	$V_{BE(ON)}$	$V_{CE}=4\text{V}$ , $I_C=2\text{A}$			2.8	
Collector-Base Cut-Off Current	$I_{CBO}$	$V_{CB}=100\text{V}$ , $I_E=0\text{A}$			1	mA
Collector-Emitter Cut-Off Current	$I_{CEO}$	$V_{CE}=50\text{V}$ , $V_B=0\text{A}$			2	mA
Emitter-Base Cut-Off Current	$I_{EBO}$	$V_{EB}=5\text{V}$ , $I_C=0\text{A}$			2	mA
DC Current Gain	$h_{FE}$	$V_{CE}=4\text{V}$ , $I_C=1\text{A}$	1000			
		$V_{CE}=4\text{V}$ , $I_C=2\text{A}$	500			
Collector Capacitance	$C_{OB}$	$V_{CB}=10\text{V}$ , $I_E=0\text{A}$ , $f=0.1\text{MHz}$			100	pF

## ■ TYPICAL CHARACTERISTICS

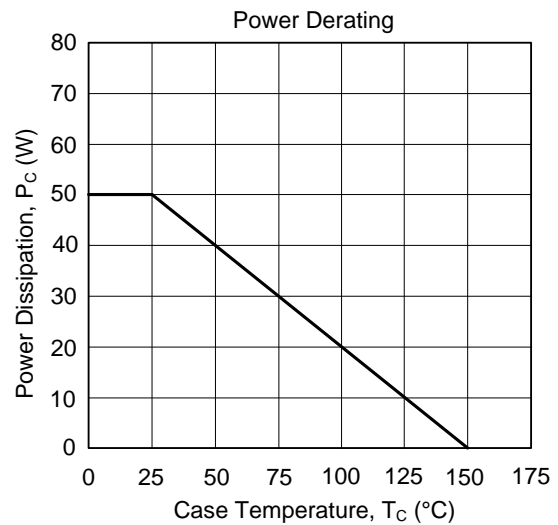
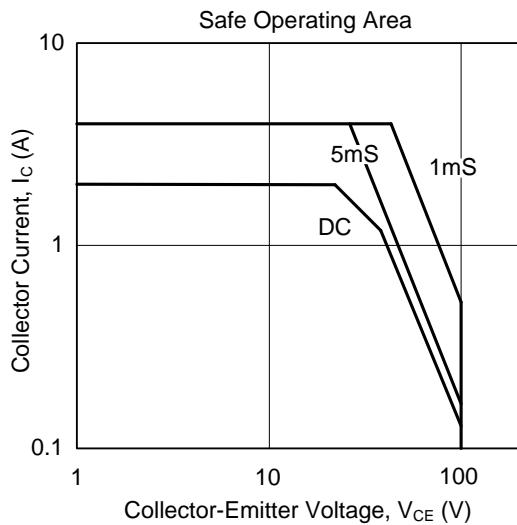
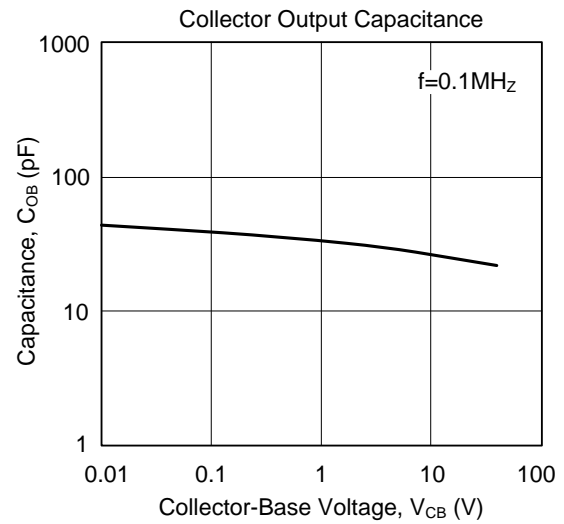
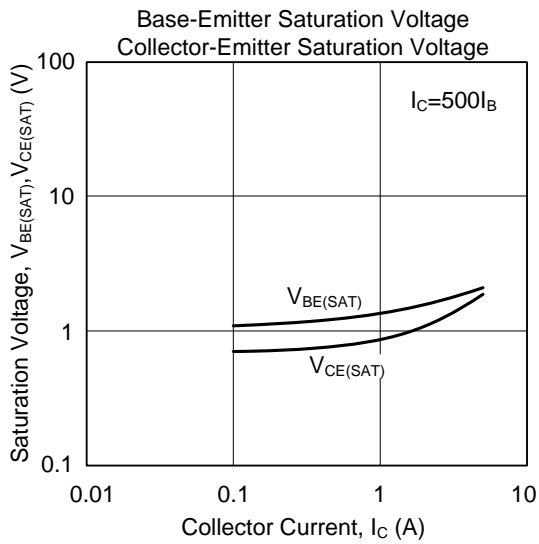
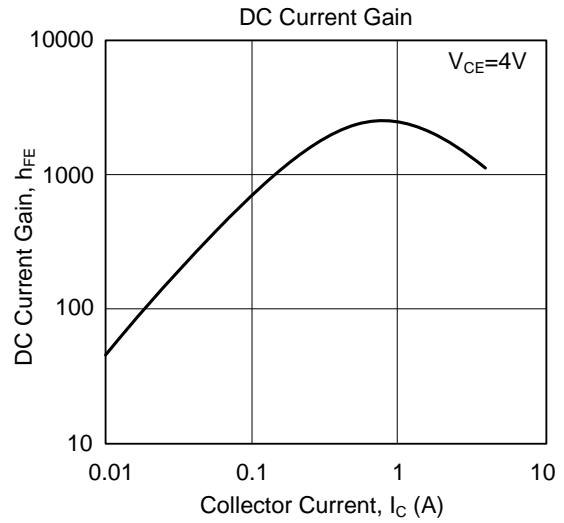
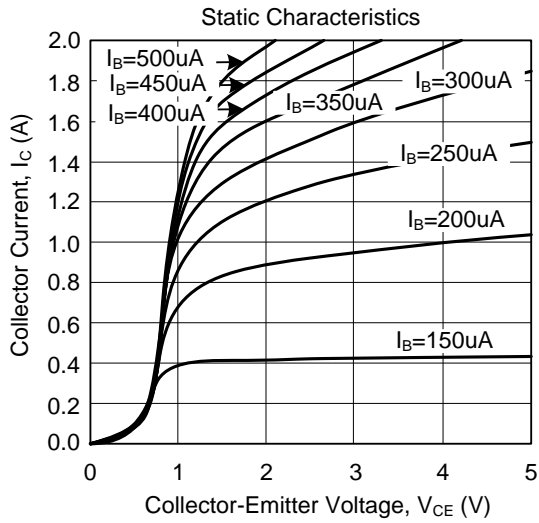

UTC assumes no responsibility for equipment failures that result from using products at values that exceed, even momentarily, rated values (such as maximum ratings, operating condition ranges, or other parameters) listed in products specifications of any and all UTC products described or contained herein. UTC products are not designed for use in life support appliances, devices or systems where malfunction of these products can be reasonably expected to result in personal injury. Reproduction in whole or in part is prohibited without the prior written consent of the copyright owner. UTC reserves the right to make changes to information published in this document, including without limitation specifications and product descriptions, at any time and without notice. This document supersedes and replaces all information supplied prior to the publication hereof.