



U74LVC2G240

CMOS IC

DUAL BUFFER/DRIVER WITH 3-STATE OUTPUTS

DESCRIPTION

The **U74LVC2G240** is a dual buffer or driver with 3-state outputs. It is designed for 1.65V to 5.5V operation.

The **U74LVC2G240** is composed of two 1-bit buffers/drivers with separate output-enable (\overline{OE}) inputs. When \overline{OE} is low, data passes from A (input) to Y (output). When \overline{OE} is high, the outputs are in the high-impedance state.

To ensure the high-impedance state during power up or power down, \overline{OE} should be tied to V_{CC} through a pull-up resistor, and the minimum value of the resistor is determined by the current-sinking capability of the driver.

The **U74LVC2G240** is fully specified for partial-power-down applications using I_{OFF} . The I_{OFF} circuitry disables the outputs and prevents damaging current backflow through the device when it is powered down.

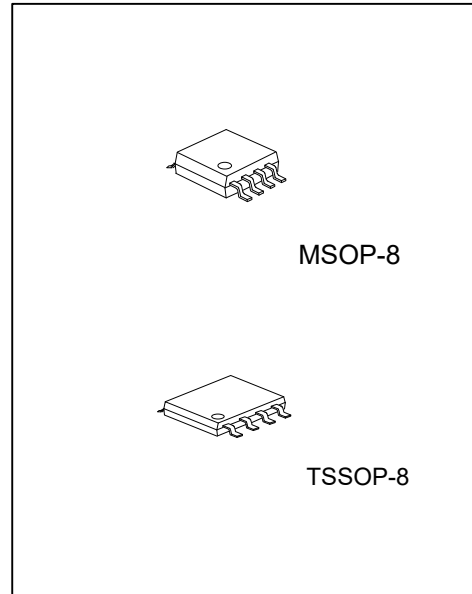

FEATURES

- * Wide Supply Voltage Range from 1.65V to 5.5V
- * Max t_{PD} of 4.6 ns at 3.3V
- * Up to 5.5V Inputs Accept Voltages
- * Low Power Consumption, $I_{CC} = 10 \mu A$ (Max.)
- * ± 24 mA Output Driver at 3.3V
- * Typical V_{OLP} (Output Ground Bounce) $< 0.8V$,
 $V_{CC} = 3.3 V$, $T_A = 25 \text{ }^\circ C$
- * Typical V_{OHV} (Output V_{OH} Undershoot) $> 2V$,
 $V_{CC} = 3.3 V$, $T_A = 25 \text{ }^\circ C$

ORDERING INFORMATION

Ordering Number		Package	Packing
Lead Free	Halogen Free		
U74LVC2G240L-SM1-R	U74LVC2G240G-SM1-R	MSOP-8	Tape Reel
U74LVC2G240L-P08-R	U74LVC2G240G-P08-R	TSSOP-8	Tape Reel

<p>U74LVC2G240G-SM1-R</p> <p>(1) Packing Type (2) Package Type (3) Green Package</p>	<p>(1) R: Tape Reel (2) SM1: MSOP-8, P08: TSSOP-8 (3) G: Halogen Free and Lead Free, L: Lead Free</p>
--	---

MARKING

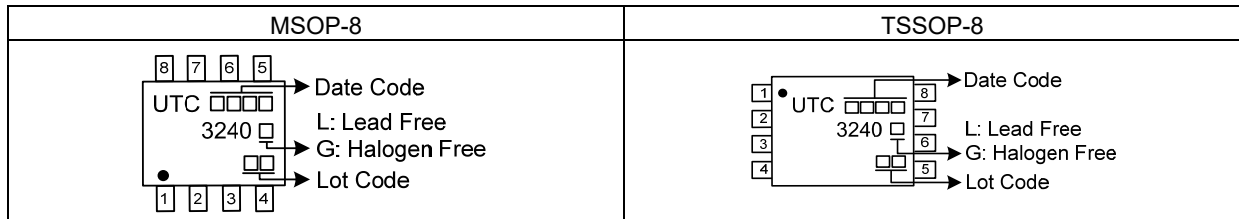

PIN CONFIGURATION

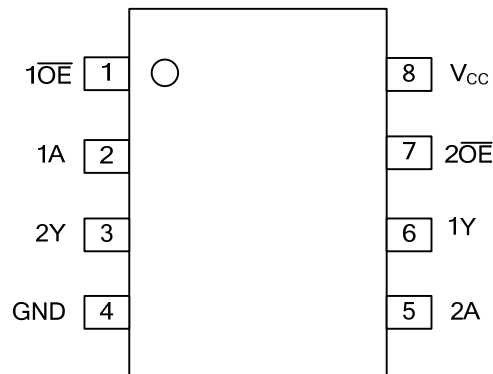

FUNCTION TABLE (Each Buffer)

INPUTS		OUTPUT
\overline{OE}	A	Y
L	H	L
L	L	H
H	X	Z

LOGIC DIAGRAM (Positive Logic)

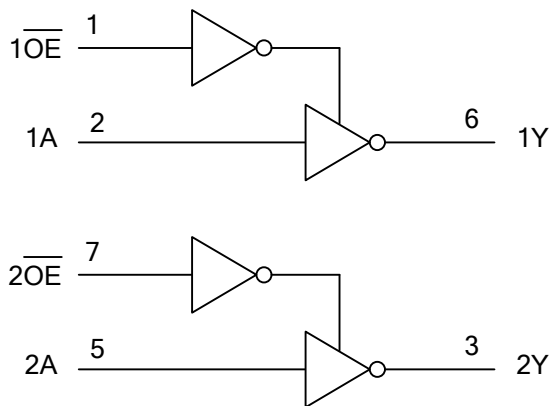

■ ABSOLUTE MAXIMUM RATING (Unless otherwise specified)

PARAMETER	SYMBOL	RATINGS	UNIT
Supply Voltage	V_{CC}	-0.5 ~ 6.5	V
Input Voltage	V_{IN}	-0.5 ~ 6.5	V
Output Voltage (any output in the high-impedance or power-off state)	V_{OUT}	-0.5 ~ 6.5	V
Output Voltage (any output in the high or low state)	V_{OUT}	-0.5 ~ $V_{CC}+0.5$	V
Input Clamp Current	I_{IK}	-50	mA
Output Clamp Current	I_{OK}	-50	mA
Output Current	I_{OUT}	±50	mA
V_{CC} or GND Current	I_{CC}	±100	mA
Storage Temperature	T_{STG}	-65 ~ +150	°C

Note: 1. The input and output voltage ratings may be exceeded if the input and output current ratings are observed.
 2. Absolute maximum ratings are those values beyond which the device could be permanently damaged.
 Absolute maximum ratings are stress ratings only and functional device operation is not implied.

■ THERMAL DATA

PARAMETER	SYMBOL	RATINGS	UNIT
Junction to Ambient	MSOP-8	220	°C/W
	TSSOP-8	190	°C/W

■ RECOMMENDED OPERATING CONDITIONS (Unless otherwise specified)

PARAMETER	SYMBOL	CONDITIONS	MIN	TYP	MAX	UNIT
Supply Voltage	V_{CC}	Operating	1.65		5.5	V
		Data retention only	1.5			
High-Level Input Voltage	V_{IH}	$V_{CC} = 1.65V$ to $1.95V$	$0.65 \times V_{CC}$			V
		$V_{CC} = 2.3V$ to $2.7V$	1.7			
		$V_{CC} = 3V$ to $3.6V$	2			
		$V_{CC} = 4.5V$ to $5.5V$	$0.7 \times V_{CC}$			
Low-Level Input Voltage	V_{IL}	$V_{CC} = 1.65V$ to $1.95V$			$0.35 \times V_{CC}$	V
		$V_{CC} = 2.3V$ to $2.7V$			0.7	
		$V_{CC} = 3V$ to $3.6V$			0.8	
		$V_{CC} = 4.5V$ to $5.5V$			$0.3 \times V_{CC}$	
Input Voltage	V_{IN}		0		5.5	V
Output Voltage	V_{OUT}	High or low state	0		V_{CC}	V
		3-state	0		5.5	
High-Level Output Current	I_{OH}	$V_{CC}=1.65V$			-4	mA
		$V_{CC}=2.3V$			-8	
		$V_{CC}=3V$			-16	
		$V_{CC}=4.5V$			-32	
Low-Level Output Current	I_{OL}	$V_{CC}=1.65V$			4	mA
		$V_{CC}=2.3V$			8	
		$V_{CC}=3V$			16	
		$V_{CC}=4.5V$			32	
Input Transition Rise or Fall Rate	t_R / t_F	$V_{CC}=1.8 \pm 0.15V, 2.5 \pm 0.2V$			20	ns/V
		$V_{CC}=3.3 \pm 0.3V$			10	
		$V_{CC}=5.0 \pm 0.5V$			5	
Operating Temperature	T_A		-40		+125	°C

■ ELECTRICAL CHARACTERISTICS ($V_{CC}=3.3V$, unless otherwise specified)

PARAMETER	SYMBOL	TEST CONDITIONS	MIN	TYP	MAX	UNIT
High-Level Output Voltage	V_{OH}	$V_{CC}=1.65V\sim 5.5V, I_{OH}=-100\mu A$	V_{CC}			V
		$V_{CC}=1.65V, I_{OH}=-4mA$	-0.1			
		$V_{CC}=2.3V, I_{OH}=-8mA$	1.2			
		$V_{CC}=3V, I_{OH}=-16mA$	1.9			
		$V_{CC}=3V, I_{OH}=-24mA$	2.4			
		$V_{CC}=4.5V, I_{OH}=-32mA$	2.3			
Low-Level Output Voltage	V_{OL}	$V_{CC}=1.65V\sim 5.5V, I_{OL}=100\mu A$			0.1	V
		$V_{CC}=1.65V, I_{OL}=4mA$			0.45	
		$V_{CC}=2.3V, I_{OL}=8mA$			0.3	
		$V_{CC}=3V, I_{OL}=16mA$			0.4	
		$V_{CC}=3V, I_{OL}=24mA$			0.55	
		$V_{CC}=4.5V, I_{OL}=32mA$			0.55	
Input Leakage Current (A or \overline{OE} inputs)	$I_{(LEAK)}$	$V_{IN} = 5.5V$ or GND, $V_{CC} = 0 \sim 5.5V$			± 5	μA
OFF-State Current	I_{OFF}	V_{IN} or $V_O = 5.5V, V_{CC} = 0V$			± 10	μA
High-Impedance State Current	I_{OZ}	$V_O = 0 \sim 5.5V, V_{CC} = 3.6V$			10	μA
Quiescent Supply Current	I_Q	$V_{IN} = 5.5V$ or GND, $I_{OUT} = 0, V_{CC} = 1.65V \sim 5.5V$			10	μA
Additional quiescent Supply Current	ΔI_Q	One input at $V_{CC} - 0.6V$; other inputs at V_{CC} or GND; $V_{CC}=3V \sim 5.5V$			500	μA
Input Capacitance	C_{IN}	$V_{IN} = V_{CC}$ or GND, $V_{CC}=3.3V$		4		pF
Output Capacitance	C_{OUT}	$V_{OUT} = V_{CC}$ or GND, $V_{CC}=3.3V$		6		pF

■ SWITCHING CHARACTERISTICS (Unless otherwise specified)

PARAMETER	SYMBOL	TEST CONDITIONS	MIN	TYP	MAX	UNIT	
Propagation Delay from Input A to Output Y	t_{PLH} / t_{PHL} (t_{PD})	$V_{CC}=1.8\pm 0.15V, R_L=1K\Omega$	$C_L=30pF$	2	11.3	ns	
		$V_{CC}=2.5\pm 0.2V, R_L=500\Omega$		1.4	5.5		
		$V_{CC}=3.3\pm 0.3V, R_L=500\Omega$	$R_L=500\Omega$	$C_L=50pF$	1.1		4.6
		$V_{CC}=5\pm 0.5V, R_L=500\Omega$			1		4
Propagation Delay from Input \overline{OE} to Output Y	t_{PZL} / t_{PZH} (t_{EN})	$V_{CC}=1.8\pm 0.15V, R_L=1K\Omega$	$C_L=30pF$	2.7	11.7	ns	
		$V_{CC}=2.5\pm 0.2V, R_L=500\Omega$		1.9	6.6		
		$V_{CC}=3.3\pm 0.3V$	$R_L=500\Omega$	$C_L=50pF$	1.4		5.4
		$V_{CC}=5\pm 0.5V$			1.1		5
Propagation Delay from Input \overline{OE} to Output Y	t_{PLZ} / t_{PHZ} (t_{DIS})	$V_{CC}=1.8\pm 0.15V, R_L=1K\Omega$	$C_L=30pF$	1.7	12.8	ns	
		$V_{CC}=2.5\pm 0.2V, R_L=500\Omega$		0.8	5.7		
		$V_{CC}=3.3\pm 0.3V$	$R_L=500\Omega$	$C_L=50pF$	1.2		5.5
		$V_{CC}=5\pm 0.5V$			0.5		4.2

■ OPERATING CHARACTERISTICS ($f=10MHz$, unless otherwise specified)

PARAMETER	SYMBOL	TEST CONDITIONS	MIN	TYP	MAX	UNIT
Power Dissipation Capacitance per buffer/driver	C_{PD}	Outputs enabled	$V_{CC} = 3.3V$		15	pF
			$V_{CC} = 5V$		17	
		Outputs disabled	$V_{CC} = 1.8V$		1	pF
			$V_{CC} = 2.5V$		1	
			$V_{CC} = 3.3V$		2	
			$V_{CC} = 5V$		2	

TEST CIRCUIT AND WAVEFORMS

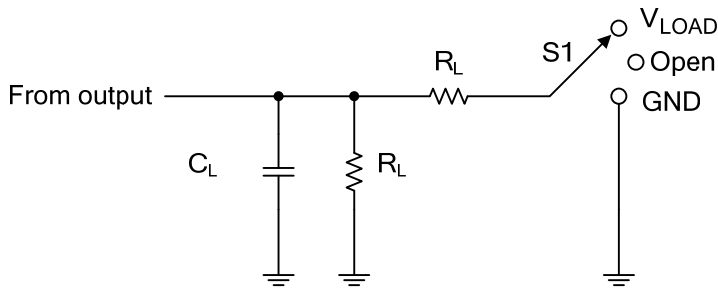

TEST	S1
t_{PLH}/t_{PHL}	Open
t_{PLZ}/t_{PZL}	V_{LOAD}
t_{PHZ}/t_{PZH}	GND

TEST CIRCUIT

V_{CC}	INPUTS		V_M	V_{LOAD}	C_L	R_L	V_{Δ}
	V_{IN}	t_r, t_f					
$1.8V \pm 0.15V$	V_{CC}	$\leq 2ns$	$V_{CC}/2$	$2 * V_{CC}$	30pF	1K Ω	0.15V
$2.5V \pm 0.2V$	V_{CC}	$\leq 2ns$	$V_{CC}/2$	$2 * V_{CC}$	30pF	500 Ω	0.15V
$3.3V \pm 0.3V$	3V	$\leq 2.5ns$	1.5V	6V	50pF	500 Ω	0.3V
$5V \pm 0.5V$	V_{CC}	$\leq 2.5ns$	$V_{CC}/2$	$2 * V_{CC}$	50pF	500 Ω	0.3V

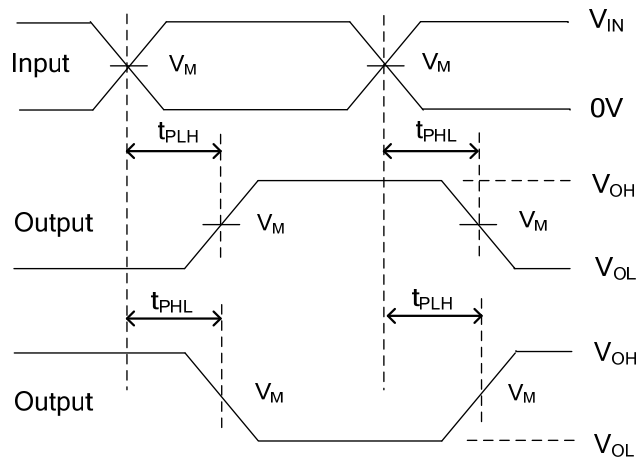

Propagation delay times
Inverting and noninverting outputs

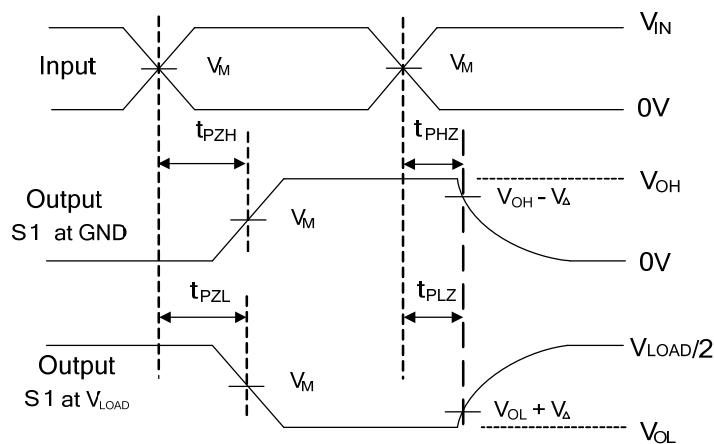

Enable and disable times
Low and high level enabling

Notes: 1. C_L includes probe and jig capacitance.

2. All input pulses are supplied by generators having the following characteristics: PRR $\leq 10MHz$, $Z_0 = 50\Omega$.

UTC assumes no responsibility for equipment failures that result from using products at values that exceed, even momentarily, rated values (such as maximum ratings, operating condition ranges, or other parameters) listed in products specifications of any and all UTC products described or contained herein. UTC products are not designed for use in life support appliances, devices or systems where malfunction of these products can be reasonably expected to result in personal injury. Reproduction in whole or in part is prohibited without the prior written consent of the copyright owner. UTC reserves the right to make changes to information published in this document, including without limitation specifications and product descriptions, at any time and without notice. This document supersedes and replaces all information supplied prior to the publication hereof.