



## PA2308

## LINEAR INTEGRATED CIRCUIT

### CLASS AB STEREO HEADPHONE DRIVER

#### DESCRIPTION

As operating on a single 5V supply, the UTC **PA2308** is capable of delivering 280mW of max. Output power to an 8Ωload or 110mW to a 32Ωload with less than 10% (THD+N).

The device is very suitable for portable digital audio application.

#### FEATURES

- \* Output power less than 10% THD+N,  $V_{DD}=5V(TYP)$ 
  - 280mW/CH (typical) into a 8Ω load
  - 110mW/CH (typical) into a 32Ω load
- \*Very High signal-to-noise ratio
- \*Large output voltage swing
- \*Good power supply ripple rejection
- \*Low power consumption and Low distortion
- \*Fix wide temperature range
- \*Without switch ON/OFF clicks

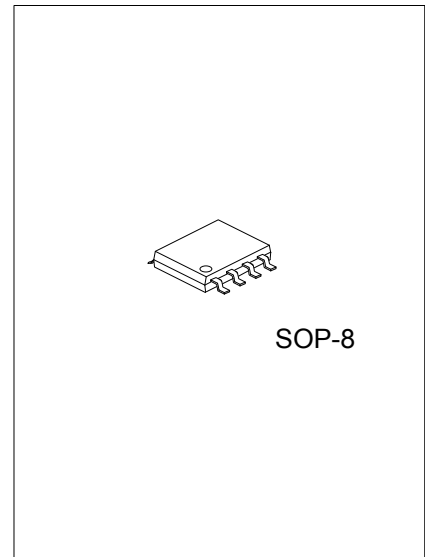

#### ORDERING INFORMATION

Ordering Number	Package	Packing
PA2308G-S08-R	SOP-8	Tape Reel

<p>PA2308G-S08-R</p> <ul style="list-style-type: none"> <li>(1) Packing Type</li> <li>(2) Package Type</li> <li>(3) Green Package</li> </ul>	<ul style="list-style-type: none"> <li>(1) R: Tape Reel</li> <li>(2) S08: SOP-8</li> <li>(3) G: Halogen Free and Lead Free</li> </ul>
--	---

#### MARKING

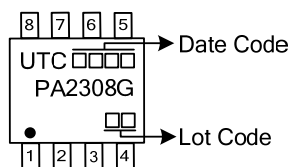

■ PIN CONFIGURATION

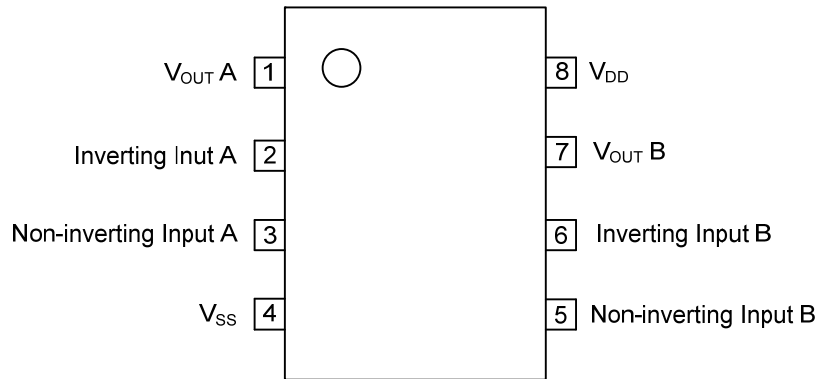

■ PIN DESCRIPTION

PIN NO.	PIN NAME	I/O	PIN DESCRIPTION
1	V <sub>OUT A</sub>	O	Channel A output pin
2	Inverting Input A	I	Inverting input for channel A
3	Non- Inverting Input A	I	Non-inverting input for channel A
4	V <sub>SS</sub>		Ground
5	Non- Inverting Input B	I	Non-inverting input for channel B
6	Inverting Input B	I	Inverting input for channel B
7	V <sub>OUT B</sub>	O	Channel B output pin
8	V <sub>DD</sub>	I	Supply voltage input pin

■ BLOCK DIAGRAM

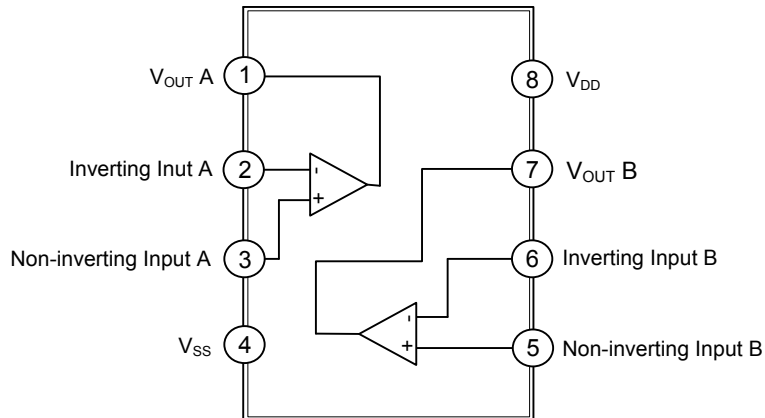

### ■ ABSOLUTE MAXIMUM RATINGS (T<sub>A</sub>=25°C)

PARAMETER	SYMBOL	RATINGS	UNIT
Supply Voltage	V <sub>DD</sub>	7	V
Junction Temperature	T <sub>J</sub>	150	°C
Operating Temperature	T <sub>OPR</sub>	-40 to 85	°C
Storage Temperature	T <sub>STG</sub>	-65 to +150	°C

Note: Absolute maximum ratings are those values beyond which the device could be permanently damaged.  
Absolute maximum ratings are stress ratings only and functional device operation is not implied.

### ■ THERMAL DATA

PARAMETER	SYMBOL	MIN	TYP	MAX	UNIT
Junction to Ambient	θ <sub>JA</sub>		210		K/W

### ■ ELECTRICAL CHARACTERISTICS(T<sub>A</sub>=25°C; unless otherwise specified)

V<sub>DD</sub>=5V, V<sub>SS</sub>=0V, f=1kHz, R<sub>L</sub>=32Ω

PARAMETER	SYMBOL	CONDITIONS	MIN	TYP	MAX	UNIT
<b>SUPPLY</b>						
Supply Voltage	Single	V <sub>DD</sub>	3.0	5.0	6.0	V
	Dual		±1.5	±2.5	±3.0	
Negative Supply Voltage	V <sub>SS</sub>		-1.5	-2.5	-3.0	V
Supply Current	I <sub>DD</sub>	No Load		2.5	5	mA
Total Power Dissipation	P <sub>D</sub>	No Load		12.5	25	mW
<b>DC CHARACTERISTICS</b>						
Input Offset Voltage	V <sub>IN(OFF)</sub>			5		mV
Input Bias Current	I <sub>BIAS</sub>			10		pA
Common Mode Voltage	V <sub>CM</sub>		0		3.5	V
Closed Loop Voltage Gain	G <sub>V</sub>	R <sub>L</sub> =5kΩ		75		dB
Max. Output Current	I <sub>OUT</sub>	(THD+N)/S<0.1%		140		mA
Output Resistance	R <sub>O</sub>			0.25		Ω
<b>AC CHARACTERISTICS</b>						
Output Voltage Swing	V <sub>OUT</sub>	R <sub>L</sub> =32Ω(Note 1)	0.25		4.75	V
		R <sub>L</sub> =16Ω(Note 1)	0.5		4.5	
Power Supply Rejection Ratio	PSRR	f <sub>IN</sub> =100Hz, V <sub>RIPPLE(P.P)</sub> =100mV		65		dB
Channel Separation	α <sub>CS</sub>	R <sub>L</sub> =32Ω		95		dB
Load Capacitance	C <sub>L</sub>				200	pF
Total Harmonic Distortion Plus Noise to Signal Ratio	(THD+N)/S	R <sub>L</sub> =32Ω(Note 2)		-65	-60	dB
				0.05	0.1	%
Signal to Noise Ratio	S/N		90	100		dB
Unity Gain Frequency	FG	R <sub>L</sub> =5kΩ		5		MHz
Max. Output Power	P <sub>OUT</sub>	(THD+N)/S<0.1%		84		mW
Input Capacitance	C <sub>I</sub>			3		PF
Power Bandwidth	B	Unity Gain Inverting		20		kHz

Notes: 1. Values are proportional to V<sub>DD</sub>; (THD+N)/S<0.1%

2. V<sub>DD</sub>=5V; V<sub>OUT(P-P)</sub>=3.5V(at 0dB)

## ■ TYPICAL APPLICATION

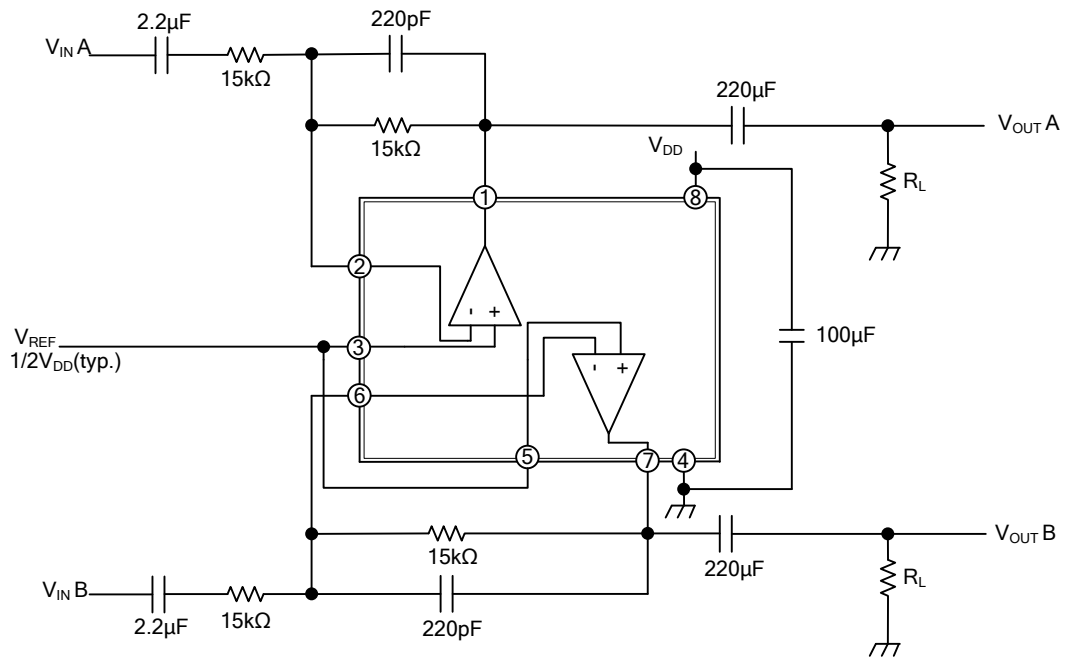

■ TYPICAL CHARACTERISTICS

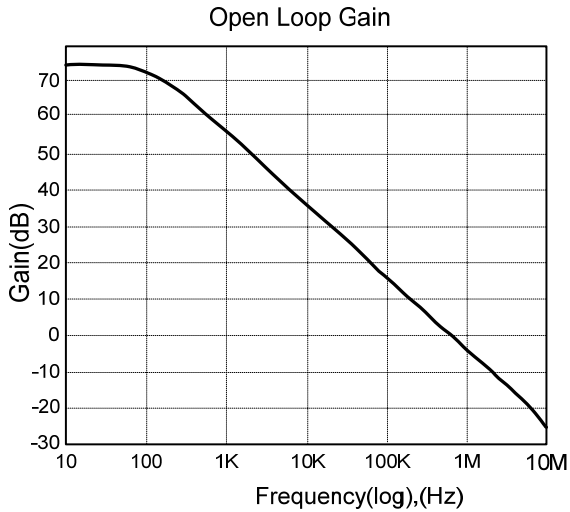
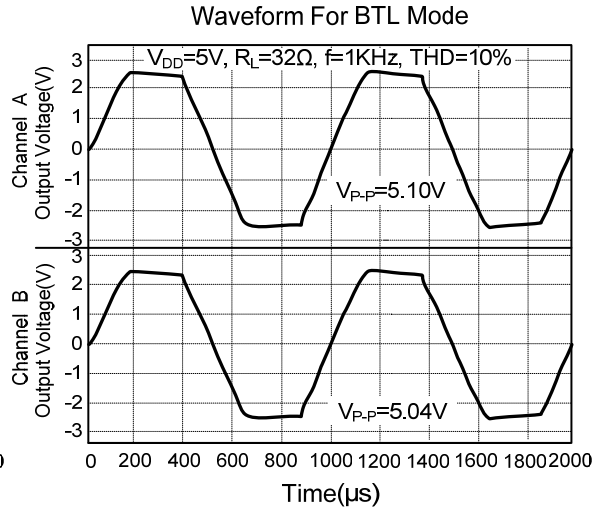
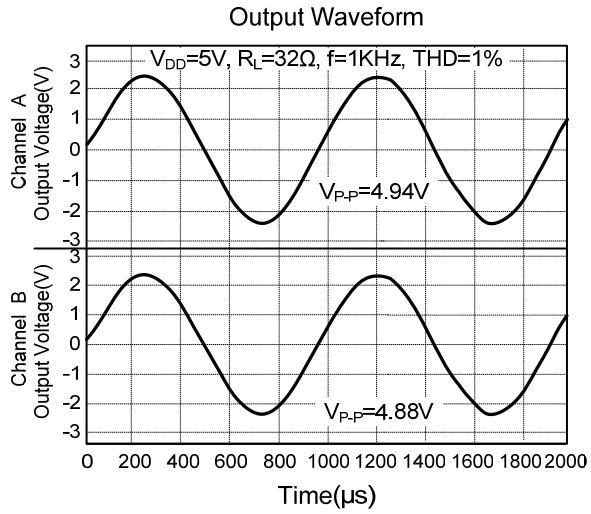

UTC assumes no responsibility for equipment failures that result from using products at values that exceed, even momentarily, rated values (such as maximum ratings, operating condition ranges, or other parameters) listed in products specifications of any and all UTC products described or contained herein. UTC products are not designed for use in life support appliances, devices or systems where malfunction of these products can be reasonably expected to result in personal injury. Reproduction in whole or in part is prohibited without the prior written consent of the copyright owner. The information presented in this document does not form part of any quotation or contract, is believed to be accurate and reliable and may be changed without notice.