

UTC 3563

LINEAR INTEGRATED CIRCUIT

HIGH-EFFICIENCY DC/DC CONVERTER

DESCRIPTION

The UTC 3563 is a monolithic control circuit containing the primary functions required for DC to DC converters and highside-sensed constant current source. The device consists of an internal temperature compensated reference, comparator, controlled duty cycle oscillator with an active current sense circuit, bootstrapped driver, and high current output switch. This device is specifically designed to construct a constant current source for battery chargers with a minimum number of external components. Bootstrapped driver can drive the NPN output switch to saturation for higher efficiency and less heat dissipation. The UTC 3563 can deliver 1.5A continuous current without requiring a heat sink.

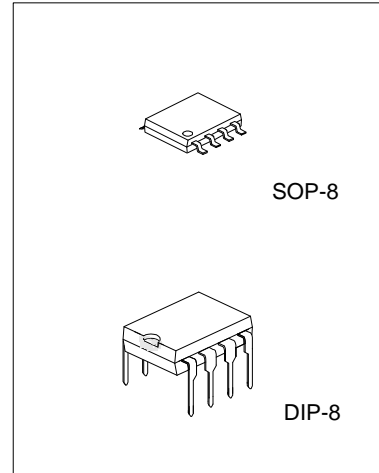

FEATURES

- *3V to 30V input voltage operation.
- *Internal 2A peak current switch.
- *1.5A continuous output current.
- *Bootstrapped driver.
- *High side current sense capability.
- *High efficiency (up to 90%)
- *Internal $\pm 2\%$ reference.
- *Low quiescent current at 1.6mA.
- *Frequency operation from 100Hz to 100KHz.

APPLICATIONS

- *Constant current source for battery chargers.
- *Saver for cellular phones.
- *Step-Down DC-DC converter module.

PIN CONFIGURATION

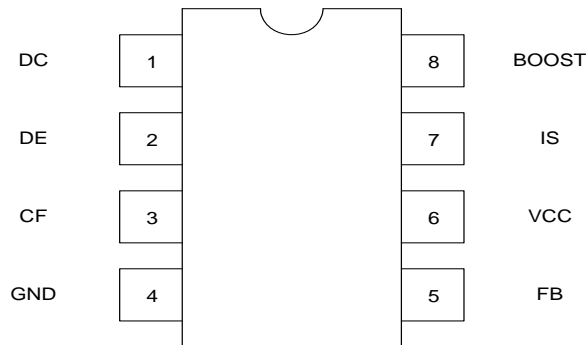

UTC 3563

LINEAR INTEGRATED CIRCUIT

BLOCK DIAGRAM

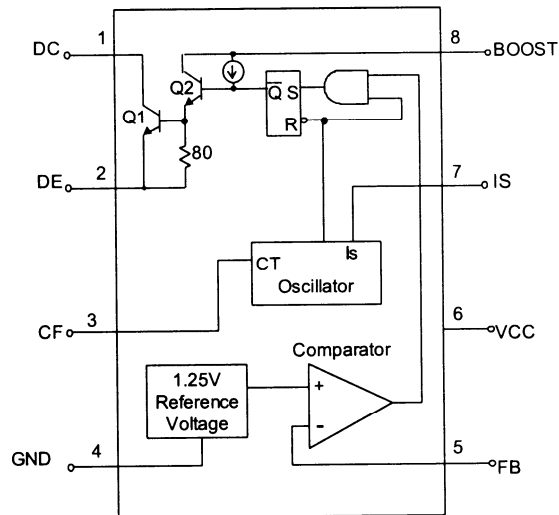

PIN	SYMBOL	DESCRIPTION	PIN	SYMBOL	DESCRIPTION
1	DC	2A switch collector	5	FB	Feedback comparator inverting input
2	DE	Darlington switch emitter	6	VCC	Power supply input
3	CF	Oscillator timing capacitor	7	IS	Highside current sense input ($V_{CC}-V_{IS}=300mV$)
4	GND	Power ground	8	BOOST	Bootstrapped driver collector

ABSOLUTE MAXIMUM RATINGS (Ta=25°C)

PARAMETER	SYMBOL	VALUE	UNIT
Supply Voltage	VCC	30	V
Comparator input voltage range	Vi	-0.3~+30	V
Switch collector voltage	Vc(switch)	30	V
Switch emitter Voltage	VE(switch)	30	V
Switch collector to emitter voltage	VCE(switch)	30	V
Driver collector Voltage	Vc(driver)	30	V
Switch current	Isw	2	A
Power dissipation (Ta=25°C)			
DIP-8		1000	mW
SOP-8		625	mW
Thermal Resistance			
DIP-8		100	°C/W
SOP-8		160	°C/W
Operating junction temperature	Tj	125	°C
Operating ambient temperature range	Ta	-20~+85	°C
Storage temperature range	Tstg	-65~+150	°C

ELECTRICAL CHARACTERISTICS (VCC=5.0V, Ta=25°C, unless otherwise specified)

PARAMETER	SYMBOL	TEST CONDITIONS	MIN	TYP.	MAX	UNIT
Oscillator						
Charging Current	ICHG	5V≤VCC≤30V	10	25	40	μA
Discharging Current	IDISCHG	5V≤VCC≤30V	100	150	200	μA
Voltage Swing	Vosc	PIN 3		0.6		V
Discharge to Charge Current Ratio	IDISCHG / ICHG	Vis=VCC		6.0		
Current limit Sense Voltage	VCC -Vis	ICHG=IDISCHG	250	300	350	mV
Output Switch						
Saturation Voltage, Emitter Follower Connection	VCE(SAT)	IDE=1.0A, VBOOST=VDC=VCC		1.5	1.8	V
Saturation Voltage	VCE(SAT)	IDC=1.0A, IBOOST=50mA, (Forced β≈20)		0.4	0.7	V
DC Current Gain	hFE	Isc=1.0A, VCE=5.0V	35	120		
Collector Off State Current	IC(OFF)	VCE=30V		10		nA
Comparator						
Threshold Voltage	VFB	Ta=25°C 0°C≤Ta≤70°C	1.225 1.210	1.250	1.275 1.290	V V
Threshold voltage Line Regulation	REGLINE	3V≤VCC≤30V		0.1	0.3	mV/V
Input Bias Current	IIB	VIN=0V		0.4	1.0	μA
Supply Current	ICC	Vis=VCC, PIN 5>VFB, 5.0V≤VCC≤30V, CT=1nF, PIN 2=GND, Remaining pins open		1.6	3.0	mA

UTC 3563

LINEAR INTEGRATED CIRCUIT

TEST CIRCUIT

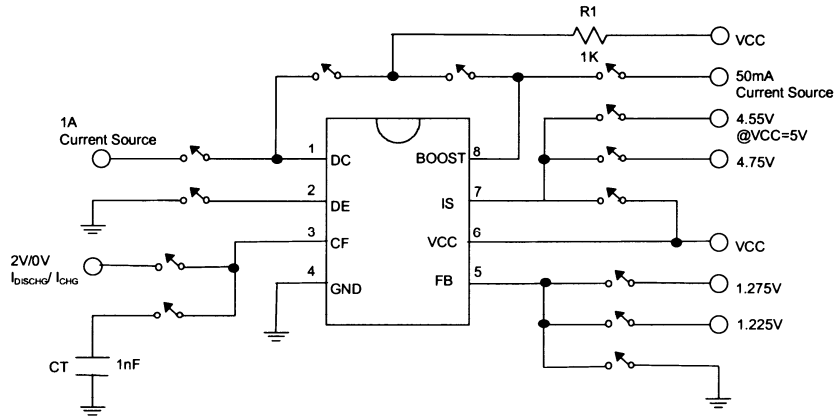

TYPICAL APPLICATION CIRCUIT

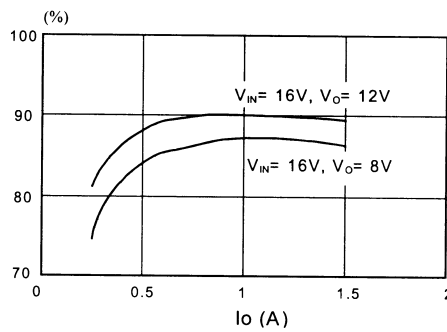
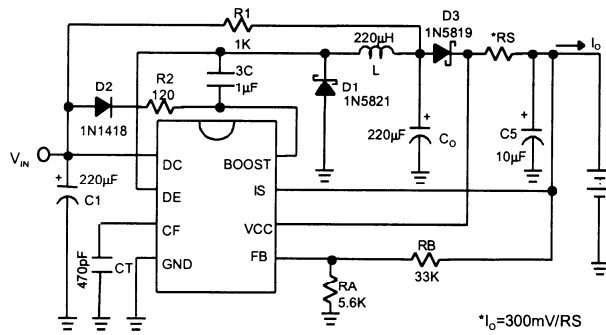

EFFICIENCY vs OUTPUT CURRENT

TYPICAL PERFORMANCE CHARACTERISTICS

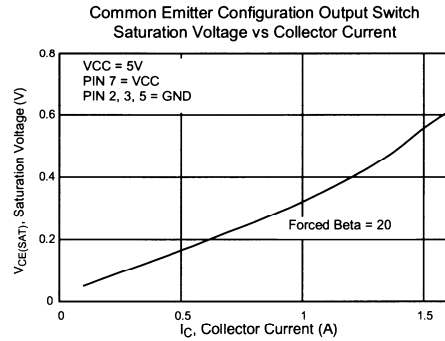
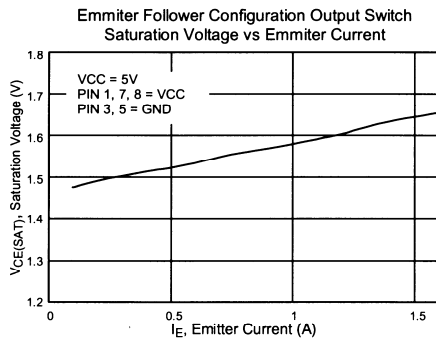
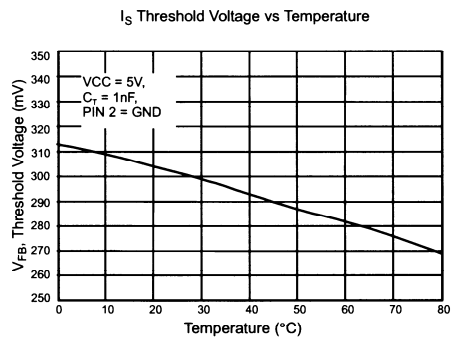
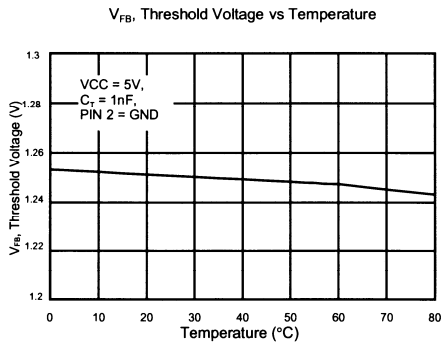
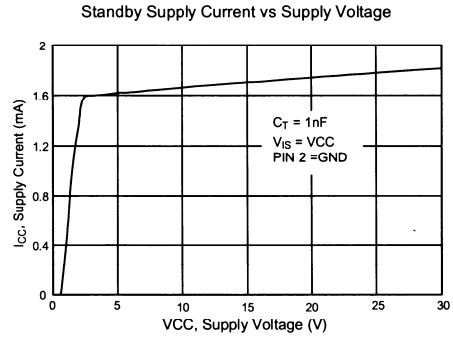
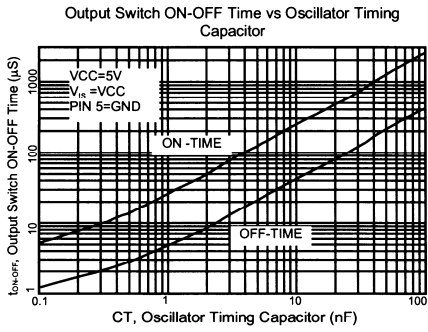

APPLICATION INFORMATION

DESIGN FORMULA TABLE

CALCULATION	STEP-DOWN	STEP-UP
t_{ON}/t_{OFF}	$\frac{V_{OUT}+V_F}{V_{IN(MIN)}-V_{SAT}-V_{OUT}}$	$\frac{V_{OUT}+V_F-V_{IN(MIN)}}{V_{IN(MIN)}-V_{SAT}}$
$(t_{ON}+t_{OFF})_{MAX}$	$1/F_{MIN}$	$1/F_{MIN}$
C_T	$4 \times 10^{-5} t_{ON}$	$4 \times 10^{-5} t_{ON}$
$I_{C(SWITCH)}$	$2I_{OUT(MAX)}$	$2I_{OUT(MAX)} \left(\frac{t_{ON} + t_{OFF}}{t_{OFF}} \right)$
R_S	$0.3/I_{C(SWITCH)}$	$0.3/I_{C(SWITCH)}$
$L(MIN)$	$\left(\frac{V_{IN(MIN)}-V_{SAT}-V_{OUT}}{I_{C(SWITCH)}} \right) t_{ON(MAX)}$	$\left(\frac{V_{IN(MIN)} - V_{SAT}}{I_{C(SWITCH)}} \right) t_{ON(MAX)}$
C_o	$\frac{I_{C(SWITCH)} (t_{ON}+t_{OFF})}{8V_{RIPPLE(P-P)}}$	$\frac{I_{OUT} t_{ON}}{V_{RIPPLE(P-P)}}$

V_{SAT} : Saturation voltage of the output switch

V_F : Forward voltage of the ringback rectifier

The following power supply characteristics must be chosen:

V_{IN} : Norminal input voltage

V_{OUT} : Desired output voltage, $V_{OUT}=1.25(1+RB/RA)$

I_{OUT} : Desired output current

F_{MIN} : Minimum desired switching frequency at selected values for V_{IN} AND I_{OUT}

$V_{RIPPLE(P-P)}$: Desired peak-to-peak output ripple voltage. In practice, the calculated value will need to be increased due to the capacitor equivalent series resistance and board layout. The ripple voltage should be kept to a low value since it will directly affect the line and load regulation.

APPLICATION EXAMPLES

Fig. 1 Simplified Battery Charge Circuit for Ni-Cd/Ni-MH Battery

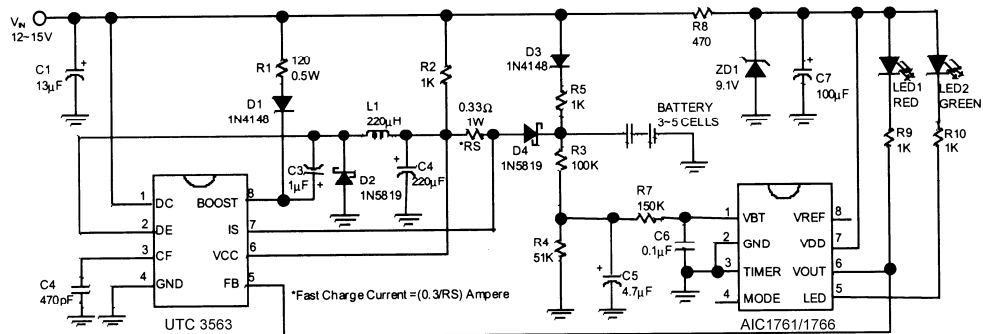

Fig.2 Battery Charge Circuit for Fluctuating Charging Current Applications

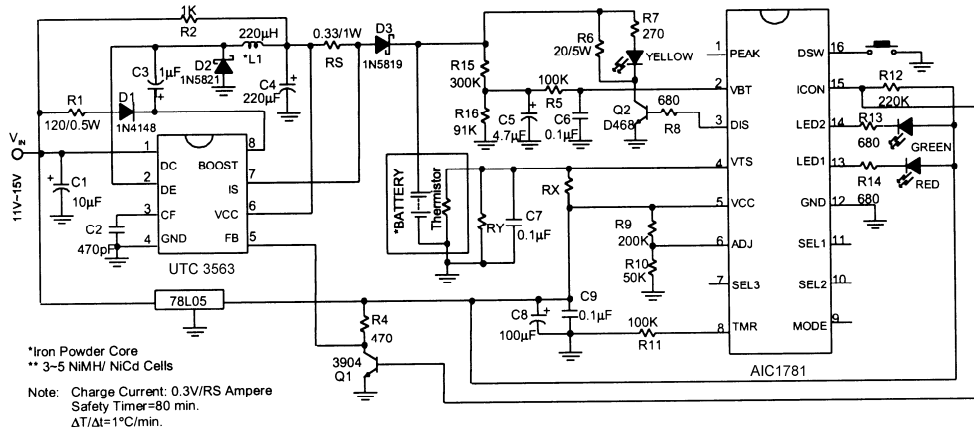
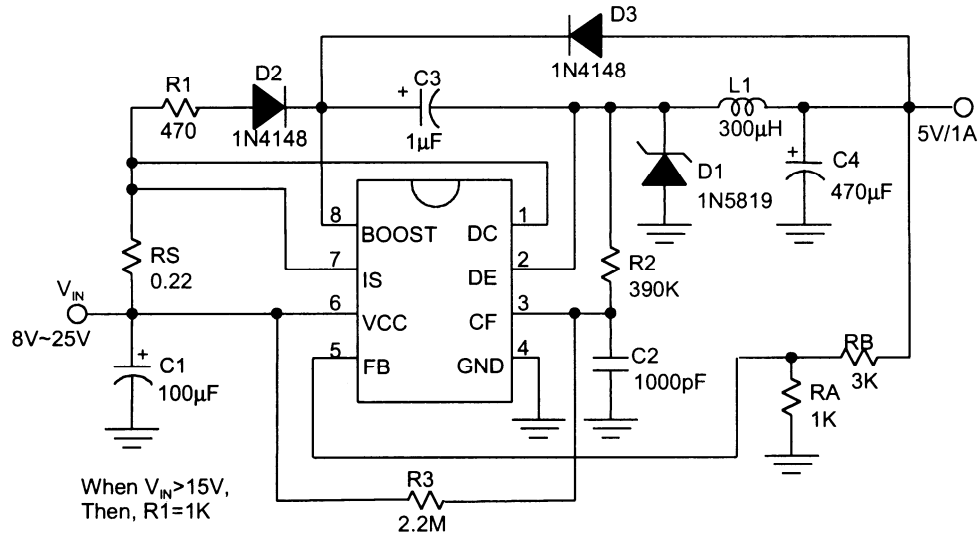

Fig. 3 Step-Down Converter



Line regulation: 40mV ($V_{IN}=10\text{V}\sim 20\text{V}$, @ $I_O=1\text{A}$)
 Load regulation: 20mV ($V_{IN}=15\text{V}$, @ $I_O=100\text{mA}\sim 1\text{A}$)
 Short circuit current: 1.3A ($V_{IN}=15\text{V}$, @ $R_L=0.1\Omega$)

UTC 3563 LINEAR INTEGRATED CIRCUIT

Fig. 4 Step-Down Converter with External 5V Bootstrap

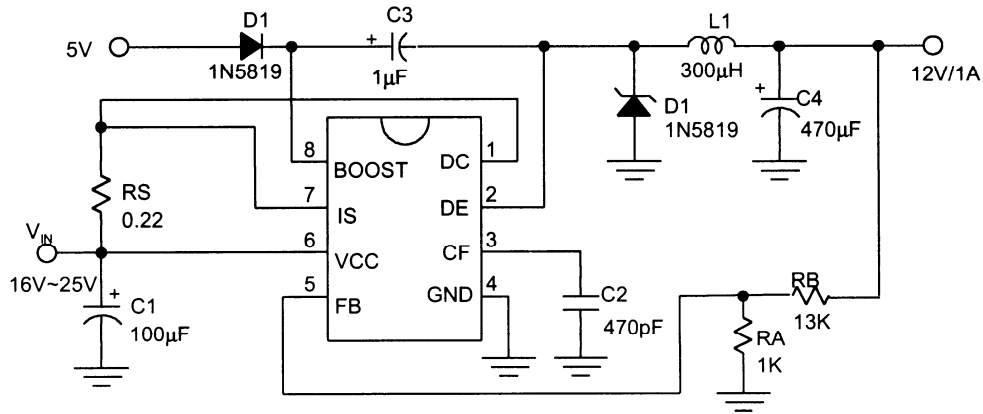
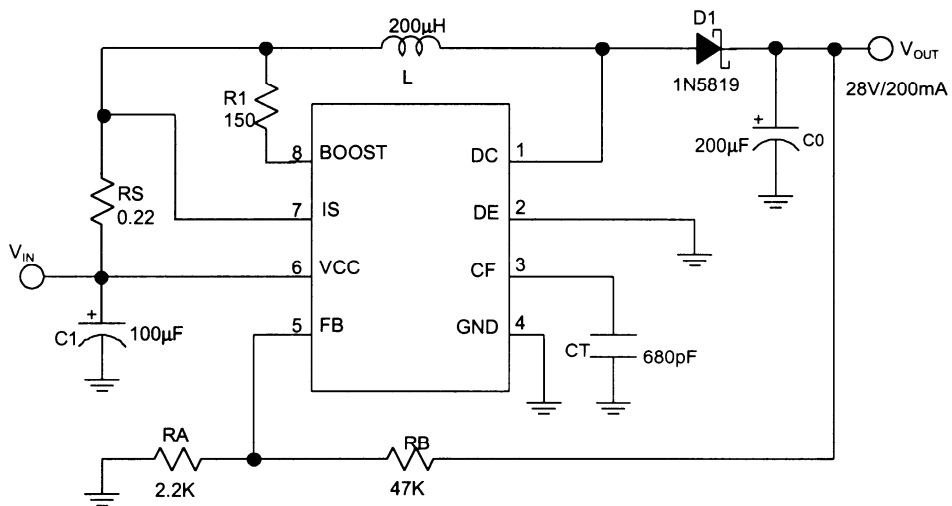

Fig. 5 Step-Up Converter



Line regulation: 100mV ($V_{IN}=8V\sim 16V$, @ $I_o=200mA$)
 Load regulation: 40mV ($V_{IN}=12V$, @ $I_o=80mA\sim 200mA$)

UTC 3563 LINEAR INTEGRATED CIRCUIT

Fig. 6 Step-Up Converter with External NPN Switch

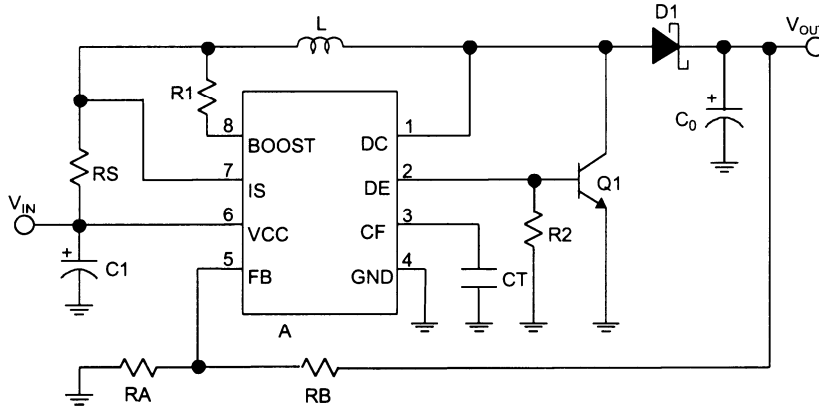
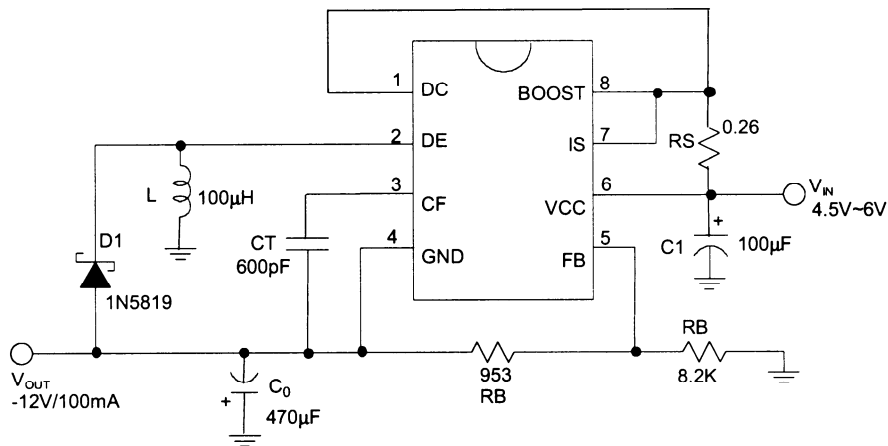

Fig. 7 Inverting Converter



Line regulation: 20mV ($V_{IN}=4.5V\sim 6V$, @ $I_O=100mA$)
 Load regulation: 100mV ($V_{IN}=5V$, @ $I_O=10mA\sim 100mA$)

UTC assumes no responsibility for equipment failures that result from using products at values that exceed, even momentarily, rated values (such as maximum ratings, operating condition ranges, or other parameters) listed in products specifications of any and all UTC products described or contained herein. UTC products are not designed for use in life support appliances, devices or systems where malfunction of these products can be reasonably expected to result in personal injury. Reproduction in whole or in part is prohibited without the prior written consent of the copyright owner. The information presented in this document does not form part of any quotation or contract, is believed to be accurate and reliable and may be changed without notice.